



**INDUSTRIAL COMMISSION OF NORTH DAKOTA**  
**CLEAN SUSTAINABLE ENERGY AUTHORITY**

Governor  
**Doug Burgum**  
Attorney General  
**Drew H. Wrigley**  
Agriculture Commissioner  
**Doug Goehring**

**Clean Sustainable Energy Authority Meeting**  
**July 25, 2023 9:00 am**  
**Bank of North Dakota Missouri River Conference Room**  
**1200 Memorial Highway, Bismarck, ND**

[Click here to join the meeting](#)

**Or call in (audio only)**

[+1 701-328-0950,,227607076#](#)

(approximately 9:00 am)

- I. Call to Order and Determination of Quorum and Opening Comments – *Rep. Glenn Bosch and Sen. Dale Patten, Co-Chairs*
  - a. Updates from Industrial Commission – *Reice Haase* (Attachment 1)

(approximately 9:30 am)

- II. **Consideration of September 8<sup>th</sup>, 2022 Technical Review Committee and September 14<sup>th</sup>, 2022 Clean Sustainable Energy Authority Meeting Minutes** (Attachment 2)

(approximately 9:40 am)

- III. Project Management and Financial Report – *Reice Haase* (Attachment 3)

(approximately 9:50 am)

- IV. **Declaration/Consideration of Conflicts of Interest** (Attachment 4)

(approximately 10:00 am)

- V. Review of Grant Round 4 Applications – Each application will include a summary from the Industrial Commission followed by a presentation by the applicant and CSEA board member questions (Attachment 5)
  - a. C-04-A – Bushel Farm Traceability Dashboard; Submitted by Bushel, Inc.; Total Project Costs: \$12,265,250; Amount Requested: \$5,529,362 grant (Attachment 6)

(approximately 10:45 am)

- b. C-04-B – SAFuels X; Submitted by AIC Energy Corp.; Total Project Costs: \$525,000,000; Amount Requested: \$5,000,000 grant, \$25,000,000 loan (Attachment 7)

(approximately 11:15 am)

- c. C-04-C – Smart Well Hub; Submitted by SandPro LLC; Total Project Costs: \$1,975,000; Amount Requested: \$705,000 grant (Attachment 8)

(approximately 12:00 pm)

10 minute break followed by a working lunch

- d. C-04-D – Project Tundra; Submitted by Minnkota Power Cooperative; Total Project Costs: \$1,400,000,000; Amount Requested: \$150,000,000 loan (Attachment 9)

(approximately 1:00 pm)

- e. C-04-E – Project Phoenix; Submitted by Newlight Technologies, Inc.; Total Project Costs: \$446,000,000; Amount Requested: \$150,000,000 loan (Attachment 10)

(approximately 1:45 pm)

- f. C-04-F – Lignite Combustion Product Enhancements; Submitted by Rainbow Energy Center; Total Project Costs: \$85,000,000; Amount Requested: \$42,500,000 loan (Attachment 11)



(approximately 2:15 pm)

- g. C-04-G – Unlocking the Full Potential of Produced Water; Submitted by WellSpring Hydro; Total Project Costs: \$250,886,700; Amount Requested: \$5,000,000 grant, \$50,000,000 loan (Attachment 12)

(approximately 3:00 pm)

- h. C-04-H – Enhancement of Energy Infrastructure; Submitted by HydroStrat GP; Total Project Costs: \$2,300,000,000; Amount Requested: \$10,000,000 grant (Attachment 13)

(approximately 3:45 pm)

---

***Consideration of motion to enter Executive Session pursuant to N.D.C.C. 54-63.1-06 and 44-04-19.2***

---

- i. *Confidential Application Attachments* (Confidential Attachments 14A – 14H)

- VI. Review of Confidential Bank of North Dakota Information – *Todd Steinwand* (Confidential Attachment 15)

(approximately 4:45 pm)

---

***Meeting Returns to Open Session***

---

- VII. **Vote on funding recommendations for each application**

- VIII. Other Business

- a. Next grant round deadline: November 1, 2023

- IX. Adjournment

**\*Bold items require Committee action.**



# INDUSTRIAL COMMISSION OF NORTH DAKOTA

Doug Burgum  
Governor

Drew H. Wrigley  
Attorney General

Doug Goehring  
Agriculture Commissioner

## Memorandum

TO: Clean Sustainable Energy Authority

FR: Reice Haase

DT: July 25<sup>th</sup>, 2023

RE: Updates from Industrial Commission

### Office of the Industrial Commission Updates:

- Karlene Fine retired in late 2022 after 52 years of service
- Office of Industrial Commission hired Brenna Jessen, Grant Program Specialist
  - Office currently has 3 Full-time and 1 Part-time Employee
  - Legislative authority to hire 2 additional FTEs
- Al Anderson announced his retirement, effective July 1st, 2023
- Office of Industrial Commission projects relevant to Clean Sustainable Energy Program:
  - Records digitization
  - Grant management software
  - Meeting management software

### Legislative Report:

The 68<sup>th</sup> Legislative Session concluded on April 30<sup>th</sup>, 2023. Highlights relevant to the Clean Sustainable Energy Program are summarized as follows:

- SB 2165 added two co-chairs, one from House and one from Senate, increasing voting membership to 9
- HB 1014 appropriated **\$30 million for grants** and made **\$250 million available for loans:**

- Repaid \$30 million of existing \$250 million line of credit
- Extended existing line of credit by \$140 million to a total of \$390 million
- Industrial Commission de-obligated \$80 million Bakken Energy loan
- \$5.3 million from de-obligated Bakken Energy CSEA Project (ARPA dollars from 2021 special session) appropriated to SERC for salt cavern project
- \$250,000 appropriated from clean sustainable energy fund for grant management expenses
- Legislative intent – support for high-voltage direct current transmission line
- HB 1379 removed the Clean Sustainable Energy Fund from legacy streams
- SB 2015 added requirement that funds approved for projects from the ND Development Fund “that enhance production of clean sustainable energy in the state” may only be approved if the project is recommended by CSEA
- SB 2015 added a requirement that CSEA develop a fertilizer development incentive program:
  - No direct appropriation, owner must borrow money under a program administered by BND
  - Funding limited to \$125 million
  - CSEA shall forgive the loan once the facility is constructed
  - CSEA shall request an appropriation from SIIF to repay
  - Fertilizer production facility within the state
  - Owner must be domiciled in the US or Canada
  - Facility must use hydrogen produced by electrolysis of water

**Board Membership:**

CSEA voting membership is as follows:

- a. Two co-chairs
  - i. Rep. Glenn Bosch and Sen. Dale Patten
- b. 2 members appointed by the lignite research council
  - i. Christopher Friez and Robert “Mac” McLennan
- c. 2 members appointed by the oil and gas research council



- i. Jim Arthaud and Kathy Neset
- d. 2 members appointed by the renewable energy council
  - i. Al Christianson and Terry Goerger
- e. 1 member appointed by the western Dakota energy association
  - i. Joel Brown

CSEA non-voting technical advisory membership is as follows:

- a. 1 member appointed by Outdoor Heritage Fund Advisory Board
  - i. Rachel Retterath
- b. Commissioner of Commerce Josh Teigen
- c. DEQ Director Dave Glatt
- d. DMR Director Lynn Helms
- e. Pipeline Authority Director Justin Kringstad
- f. Transmission Authority Director John Weeda
- g. SERC Director or SERC Designee Tom Erickson/Charles Gorecki
- h. BND President Todd Steinwand

Minutes of a Meeting of the Clean Sustainable Energy Authority Technical Review Committee

Held on September 8, 2022 at 1:30 p.m.

DMR West Conference Room, 1000 E Calgary Ave

Present: Lt. Governor Brent Sanford, Chair  
Lynn Helms  
Justin Kringstad  
Rachel Retterath  
Todd Steinwand  
Dave Glatt  
Rich Garman  
John Weeda  
Kelvin Hullet  
Al Anderson  
Karlene Fine  
Reice Haase

Also Present: Not all attendees are known as this meeting was held through Microsoft Teams.

Lt. Governor Brent Sanford called the meeting of the Clean Sustainable Energy Authority Technical Review Committee to order at 1:30 p.m.

Lt. Governor Sanford mentioned that there is a quorum present in this meeting.

Under other business, Mr. Al Anderson requested input from the technical committee on policy recommendations.

**It was moved by Mr. Steinwand and seconded by Retterath that the September 8, 2023 agenda be approved as presented. The motion carried unanimously.**

**It was moved by Ms. Retterath and seconded by Kringstad to approve the May 10, 2023 meeting minutes as presented. The motion carried unanimously.**

Ms. Karlene Fine, Industrial Commission Executive Director/Secretary, provided a financial summary as follows:

The administrative costs were increased to \$60,000. There is \$5.9 million in grant funds available, \$10 million available for hydrogen. An explanation of what hydrogen dollars are was given, explaining it only gets dispersed because it is ARPA federal dollars. So far \$4 million has been expended from federal grants, and there is currently a \$20.9 million cash balance.

Lt. Governor Sanford requested the members to declare any conflicts of interest, to which there were no conflicts.

The review of applications began: There were five applications, but two applicants withdrew. The three remaining projects had positive technical reviews.

### C-03-01 Liberty H2 Hub

- \$10 million grant request
- Mr. John Weeda shared concerns about hydrogen thermodynamics but is overall generally supportive. He shares the Governor's concern that there should only be one hub from North Dakota.
- Glatt shared concerns about throwing money at it and it fizzles, but agreed it is getting a lot of attention nationally.
- Mr. Todd Steinwand mentioned that there is a lot of large-scale federal funding available, and that North Dakota has the opportunity to drive this technology forward as real dollars are being committed here. It was also mentioned that the market will choose which hub is more feasible and that having the right management and right time will help pull it off.
- Mr. Justin Kringstad is encouraged to see TC Energy as a player. Marathon has a long-standing track record with midstream, and the team has strong assets and expertise.

### C-03-02 Newlight

- \$4.185 million grant request
- The technical reviewers' comments were mostly positive and believe the research and development to be cutting edge.
- The risks that were noted were the lack of commitment to build in North Dakota, they are building a plant in Ohio currently, the concern of there being enough demand to support two plants, and whether there is enough capacity to raise funds.
- Ms. Rachel Retterath noted that they mentioned having a location identified in North Dakota and asked what sets North Dakota apart. Lt. Governor Sanford responded that we have feedstock and one of the individuals involved is from North Dakota.
- Mr. Kelvin Hullet said the Investment Committee had similar concerns with providing funding without commitment.
- Mr. Kringstad asked if there was any volume information in the application to which there was not.
- Mr. Al Anderson made a suggestion of having a mutual agreement with the applicant that North Dakota funding would only fund the North Dakota FEED study.
- Mr. John Weeda commented that he hopes we can make this work, stating that infrastructure needs big picture approach at Marley Crossing.
- Mr. Lynn Helms stated that he would have liked more firm commitment to North Dakota over Ohio, but he is still strongly in favor of the project and that we have the right geography.
- Lt. Governor Sanford completed the conversation with stating that this project would be a great opportunity for the state of North Dakota.

### C-03-03 Enerplus Geothermal

- \$1.09 million grant request
- Two technical reviewers rated this project as favorable, and one reviewer rated the project as questionable.
- The risks that were noted were cost competitiveness of power generation, and concerns about CSEA reporting and lack of technical information.

- Overall, they are going forward with the proposal and additional information will be learned and shared. It was mentioned that this could reduce net carbon footprint for the state of North Dakota.
- Mr. Weeda stated that this project is interesting, but that there is not enough technical information to satisfy thermal curiosity. He believes a pilot test is in order and that it would be difficult if the primary source of electricity is from utility. His vote would be to support this project.
- Mr. Kringstad said he is a big fan of geothermal. He mentioned concerns related to volumes on page 9 of the application stating that they are mostly targeting flowback water. UND and EERC had a similar project looking at lower flow in the Cedar Hills, and if this equipment requires this large of a flow, it will limit it. There are no comments about how long it can run before it needs to be turned off.
- Mr. Helms stated that the area that Enerplus operates in is a lower-water cut area, but they are seeing more development in lower-tier areas with higher water cut. He said the project is innovative and that they've seen projects with incredible amounts of heat being wasted with chillers. He mentioned this area is challenged with getting electricity from the RECs and that it would be incredible to deploy this in the fringes in the Bakken. He ended by stating that this is a solid company that can follow-through on the project.
- Lt. Governor Sanford ended the conversation with stating that Enerplus's last project was to reduce emissions from on-site generation, that this project would complement that, and that most of these projects are not connected to the grid.

Lt. Governor Sanford asked for a motion to be made to enter into executive session to discuss confidential information.

**A motion was made by Mr. Steinwand and seconded by Mr. Helms that under the authority of the N.D.C.C. 54-63.1-06 and 44-04-19.2.1 that the Clean Sustainable Authority Technical Review Committee enter into an executive session for the purpose of considering Clean Sustainable Energy confidential information.**

**On a roll call vote Dave Glatt, Lynn Helms, Justin Kringstad, Rich Garman, Rachel Retterath, and Todd Steinwand all voted aye. The motion carried unanimously.**

**Lt. Governor Sanford stated that the Clean Sustainable Energy Authority Technical Committee is entering into executive session to discuss confidential information. He stated that only CSEA members and ND Industrial Commission staff will be present during executive session. Any formal action will be taken in open session. Lt. Governor Sanford reminded those present that the discussion must be limited to the announced purpose which is projected to last approximately 30 minutes.**

The executive session began at 2:15 p.m.

**The Meeting Closed to the Public for Executive Session Pursuant to NDCC 54-63.1-06 and 44-04-19.2.1.**

---

**CLEAN SUSTAINABLE ENERGY AUTHORITY TECH COMMITTEE EXECUTIVE SESSION**

**Present:**

Lt. Governor Brent Sanford  
Lynn Helms

Justin Kringstad  
Rachel Retterath  
Todd Steinwand  
Dave Glatt  
Rich Garman  
John Weeda  
Kelvin Hullet  
Karlene Fine  
Reice Haase  
Karen Tyler

---

Executive session ended at 2:52 p.m and reconvened in open session.

Voting results are as follows:

C-03-01:

- Average 41, feasible
- Ms. Retterath would like to see a condition to ensure that everyone is working together and not against one another.
- Mr. Anderson said they would need to think about how to build that into a contract.
- Lt. Governor Sanford mentioned that it was not built into the first award.
- Mr. Steinwand said they could strongly suggest it, but that these are private entities, and they will likely be reluctant.
- Lt. Governor Sanford said that it needs to happen on DOE application.
- Mr. Anderson said they have several options, whether they fund full or partial.
- Mr. Helms stated that he does not want to handicap one of the parties with a condition that was not placed on the other and suggested that no conditions be placed.

**A motion was made by Mr. Helms and seconded by Mr. Kringstad to recommend fully funding the C-03-01 Liberty H2 Hub for the \$10 million grant request.**

**On a roll vote Lynn Helms, Justin Kringstad, Rich Garman, Rachel Retterath, Todd Steinwand, and Dave Glatt all voted aye. Motion carried unanimously.**

C-03-02:

- Average 39, feasible with conditions
- Mr. Helms stated that he would like to see a condition to ensure infrastructure is built in North Dakota.
- Lt. Governor Sandford asked if it should be contingent on land purchase or if it should be left to the CSEA board to make that decision.
- Mr. Steinwand mentioned that they have a call with them and can explore covenant possibilities ahead of the CSEA board meeting.

**A motion was made by Mr. Glatt and seconded by Ms. Retterath to recommend funding C-03-02 Newlight, with the added conditions for the \$4.185 million grant request.**

**On a roll vote Lynn Helms, Justin Kringstad, Rich Garman, Rachel Retterath, Todd Steinwand, and Dave Glatt all voted aye. Motion carried unanimously.**

C-03-03:

- Average 38, feasible with no conditions

**A motion was made by Mr. Garman and seconded by Mr. Helms to recommend funding C-03-03 for the \$1.09 million grant request.**

- Mr. Glatt asked if they can provide how much energy they saved and how much emissions they averted.
- Mr. Anderson said yes, and that we need someone to monitor what they provide back to us. He mentioned that someone who has the expertise should assist in drafting the contract such as Dave.
- Mr. Helms stated that they are eager to share information with the NDIC, which should ensure they have robust results presentations, and maybe present at petroleum conferences, etc. They are willing to share non-proprietary information so we should hold them to it.
- Mr. Kringstad asked if that should be included as a condition?

**A motion was by Mr. Helms and seconded by Mr. Garman to amend the previous motion to recommend funding C-03-03 with the added conditions for the \$1.09 million grant request.**

**On a roll vote Lynn Helms, Justin Kringstad, Rich Garman, Rachel Retterath, Todd Steinwand, and Dave Glatt all voted aye. Motion carried unanimously.**

Under other business, the following policy recommendations were discussed:

The first policy recommendation was that no grant rounds will be held if remaining funding does not meet minimum application levels.

- Mr. Glatt said he would like to schedule follow-up meetings to track project statuses.
- Mr. Steinwand agreed that it makes sense to not hold a grant round if funding does not meet minimum application levels.
- Mr. Anderson mentioned that so far, all projects are on task, and he plans on providing the numbers to the CSEA board.
- Mr. Glatt stated that it is good to have checks, and that the technical committee can provide input as projects progress.
- Mr. Anderson said that he will have a template to share at the full CSEA board meeting.

The second policy recommendation was that rejected applications are only eligible for reconsideration if certain changes are met.

- Mr. Anderson took the recommendations from the LIFT program.
- Mr. Steinwand agreed that the criteria necessary to be reconsidered makes sense.
- Mr. Helms stated that six months seems short and that he would have gone with a year. He also mentioned that he didn't understand what "financial judgement" means.
- Mr. Steinwand stated that one could interpret it to mean change in financial situation from original application.

- Mr. Hullet mentioned that this policy recommendation would change the Bank’s evaluation of feasibility and profitability.
- Mr. Helms made a suggestion to change the language to “financial feasibility”.
- Mr. Steinwand stated that things change rapidly, but could enough change happen in six months?
- Mr. Helms stated that he does not want to see the same projects at every meeting.
- Ms. Retterath said that a lot can change in a six-month period.
- Mr. Glatt agreed with Ms. Retterath that situations can change rapidly.

Another policy recommendation was that projects that have received grant funding cannot receive more funding except for extenuating circumstances.

- Lt. Governor Sanford agreed saying it is putting existing practice into writing.

With no further business, Lt. Governor Sanford adjourned the meeting at 3:15 p.m.

---

Rep. Glenn Bosch, Co-chairman

---

Sen. Dale Patten, Co-chairman



# CLEAN SUSTAINABLE ENERGY AUTHORITY PROJECT MANAGEMENT AND FINANCIAL REPORT

Reice Haase, Deputy Executive Director, NDIC

July 18, 2023



NORTH  
**Dakota**

Be Legendary.™



# ACTIVE PROJECTS

**10**

Active Projects

**\$15.6 Million\***

Paid To Date

**\$44.3 Million**

Awarded Dollars

**\$23.3 Million**

Payable Dollars

**\$30.4 Million**

Cash Available for Commitment in  
2023-2025 biennium

# Clean Sustainable Energy Fund

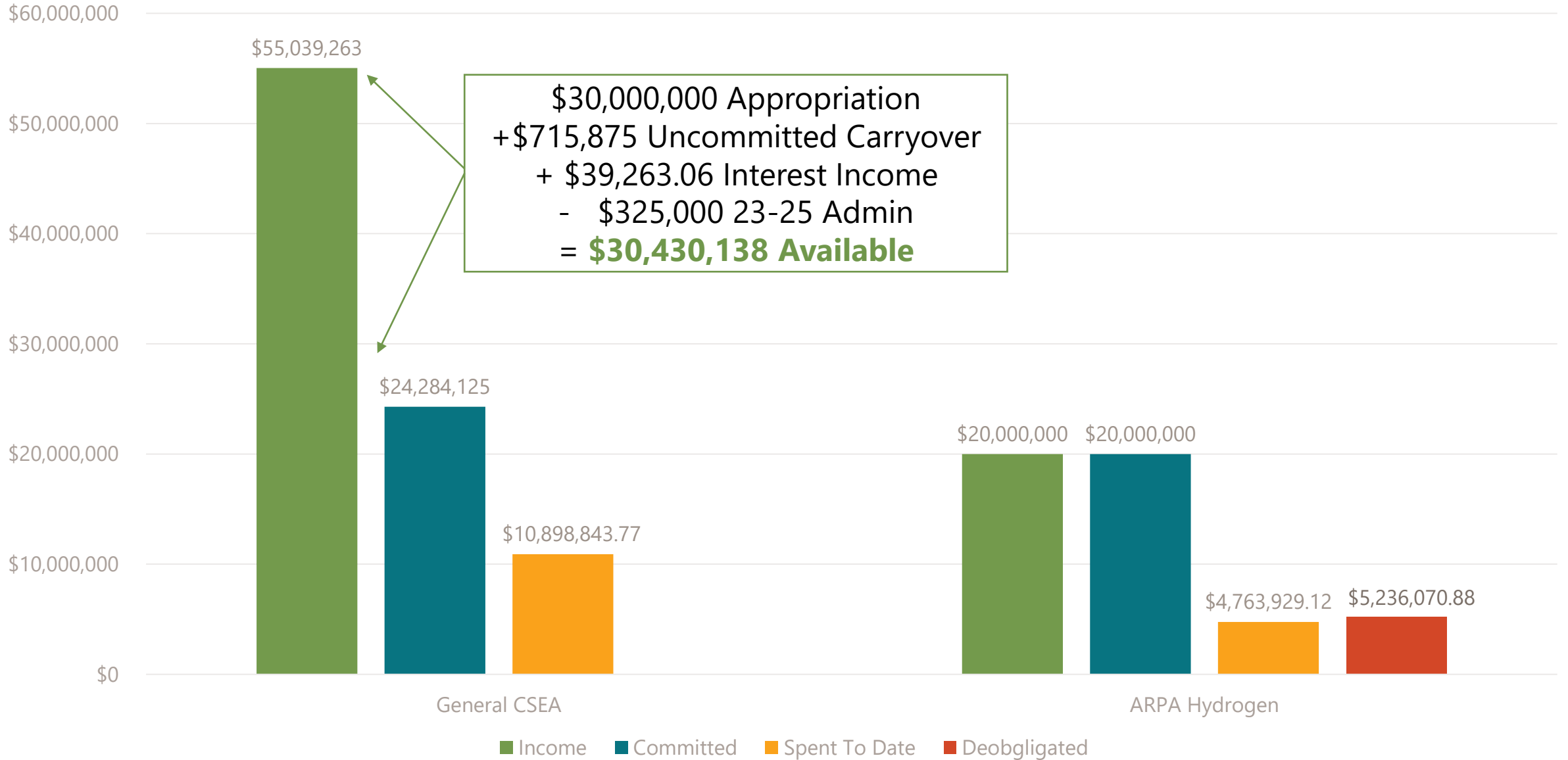

# CSEA Project Status

Project Name	Company	Total Project Cost	Loan	Grant Commitment	Spent to Date	Deobligation	Remaining Obligation
Dakota H2 Hub	Bakken Energy LLC	1,750,000,000.00	80,000,000.00	10,000,000.00	4,763,929.12	5,236,070.88	-
Cerilon GTL	Cerilon GTL ND Inc. GTL Project	2,800,000,000.00	40,000,000.00	7,000,000.00	6,300,000.00	-	700,000.00
Unlocking the Full Potential of Produced Water as a key Component of Clean Sustainable Energy	Wellspring Hydro	2,200,000.00	-	1,000,000.00	366,086.50	-	633,913.50
Commercial Deployment of Carbon Dioxide Capture & Geological Sequestration in McLean County	Midwest AgEnergy Group	58,800,000.00	15,000,000.00	3,000,000.00	2,700,000.00	-	300,000.00
Front-End Engineering and Design for CO2 Capture at Coal Creek Station	Energy & Environmental Research Center (EERC)	15,065,200.00	-	7,000,000.00	1,532,757.27	-	5,467,242.73
Solving North Dakota Flaring	Valence Natural Gas Solutions	44,000,000.00	15,000,000.00	-	-	-	-
Internal Combustion Engine Carbon Capture and Sequestration	Enerplus Resources (USA) Corporation	18,110,000.00	-	1,000,000.00	-	-	1,000,000.00
Project Tundra	Minnkota Power Cooperative	1,400,000,000.00	100,000,000.00	-	-	-	-
Liberty H2 Hub Front-End Engineering and Design	Energy & Environmental Research Center (EERC)	24,290,528.00	-	10,000,000.00	-	-	10,000,000.00
Project Phoenix: Manufacturing bio-degradable polymers using methane as a feedstock	Newlight Technologies	8,371,250.00	-	4,185,625.00	-	-	4,185,625.00
Geothermal Power Generation for Oil and Gas Production	Enerplus (USA) Corporation	2,197,000.00	-	1,098,500.00	-	-	1,098,500.00
		<b>4,373,033,978.00</b>	<b>170,000,000.00</b>	<b>44,284,125.00</b>	<b>15,662,772.89</b>	<b>5,236,070.88</b>	<b>23,385,281.23</b>

# PROJECT HIGHLIGHT: VALENCE



Captured over 1.7 Billion Cubic Feet (“BCF”) of otherwise flared gas



Emissions reductions of over 155,000 tons of CO<sub>2</sub>e



= \$31.3 Million in additional tax revenue to the state



CLEAN SUSTAINABLE ENERGY AUTHORITY  
CONFLICT OF INTEREST  
DISCLOSURE FORM

A conflict of interest may develop for Clean Sustainable Energy Authority members as a result of considering applications for funding from the Clean Sustainable Energy Authority Fund. A conflict of interest exists for an Authority member if there is a monetary or material investment or interest in a project submitted for Authority consideration, such as employment or individual investment. **If a conflict of interest exists, then the member must disclose the nature of the conflict of interest prior to any vote by the Authority in consideration of the application. A motion must be approved to allow members with conflicts of interest to vote.**

**Grant Round 4:**

Conflict of Interest		
	Yes	No
C-04-A – Bushel Farm Traceability Dashboard; Submitted by Bushel, Inc.; Total Project Costs: \$12,265,250; Amount Requested: \$5,529,362 grant		
C-04-B – SAFuels X; Submitted by AIC Energy Corp.; Total Project Costs: \$525,000,000; Amount Requested: \$5,000,000 grant, \$25,000,000 loan		
C-04-C – Smart Well Hub; Submitted by SandPro LLC; Total Project Costs: \$1,975,000; Amount Requested: \$705,000 grant		
C-04-D – Project Tundra; Submitted by Minnkota Power Cooperative; Total Project Costs: \$1,400,000,000; Amount Requested: \$150,000,000 loan		
C-04-E – Project Phoenix; Submitted by Newlight Technologies, Inc.; Total Project Costs: \$446,000,000; Amount Requested: \$150,000,000 loan		
C-04-F – Lignite Combustion Product Enhancements; Submitted by Rainbow Energy Center; Total Project Costs: \$85,000,000; Amount Requested: \$42,500,000 loan		
C-04-G – Unlocking the Full Potential of Produced Water; Submitted by WellSpring Hydro; Total Project Costs: \$250,886,700; Amount Requested: \$5,000,000 grant, \$50,000,000 loan		
C-04-H – Enhancement of Energy Infrastructure; Submitted by HydroStrat GP; Total Project Costs: \$2,300,000,000; Amount Requested: \$10,000,000 grant		

**Print** - CSEA Member \_\_\_\_\_

**Signature** - CSEA Member \_\_\_\_\_

**Clean Sustainable Energy Authority  
Grant Round 4 Applications (May 2023)**

Grant #	Application Title	Applicant	Principal Investigator	Grant Funding Requested	Loan Requested	Total Project Costs	Category	Duration
C-04-A	Bushel Farm Traceability Dashboard	Bushel, Inc.	Luke Swenson	\$5,529,362	\$0	\$12,265,250	IT/Agriculture	36 months
C-04-B	SAFuels X	AIC Energy Corp.	John Melk	\$5,000,000	\$25,000,000	\$525,000,000	Biofuels Refinery	24 months
C-04-C	Smart Well Hub	SandPro LLC	Andrew Emmel	\$705,000	\$0	\$1,975,000	Wellsite optimization	12 months
C-04-D	Project Tundra	Minnkota Power Cooperative	Andrew Sorbo	\$0	\$150,000,000	\$1,400,000,000	Carbon Capture	4 years
C-04-E	Project Phoenix	Newlight Technologies, Inc.	Kenton Kimmel	\$0	\$150,000,000	\$446,000,000	Carbon-negative manufacturing	35 months
C-04-F	Lignite Combustion Product Enhancements	Rainbow Energy Center	Jessica Bell	\$0	\$42,500,000	\$85,000,000	Coal Facility Waste	30 months
C-04-G	Unlocking the Full Potential of Produced Water	WellSpring Hydro	Mark Watson	\$5,000,000	\$50,000,000	\$250,886,700	Produced Water	26 months
C-04-H	Enhancement of Energy Infrastructure	HydroStrat GP	Curtis Johnson	\$10,000,000	\$0	\$2,300,000,000	Produced Water	3 years
				<b>\$26,234,362</b>	<b>\$417,500,000</b>	<b>\$5,021,126,950</b>		

Submitted by: Bushel, Inc.  
 Project Duration: 36 months  
 Total Project Costs: \$12,265,250  
 Request for: \$5,529,362 grant

**Summary of Project:** This project supports the creation of a farm traceability dashboard for tracking carbon reductions in production agriculture.

**Technical Review Results**

Overall Technically Sound (217/315)	
Good	1
Fair	2
Questionable	

**BND Economic Feasibility Recommendation**

Overall Economic Feasibility	
Yes	X
No	

**Technical Committee Scores**

	Score (Out of 50)
Charlie Gorecki	28
Josh Teigen	40
Dave Glatt	25
Lynn Helms	38
Justin Kringstad	35
Rachel Retterath	37
Todd Steinwand	33
John Weeda	25 with condition

Average: 33

**Recommendation: 8-0 Consider funding with condition that CSEA Board determines the project is eligible for the program**

# TECHNICAL REVIEWERS' RATING SUMMARY

## C-04-A

Bushel Farm Traceability Dashboard

Submitted By: Bushel, Inc.

Date of Application: May 2023

**Request for \$5,529,362 Grant**

**Total Project Costs \$12,265,250**

Rating Category	Weighting Factor	Technical Reviewer			Average Weighted Score
		A1 Rating	A2 Rating	A3 Rating	
1. Objectives	3	3	4	4	11
2. Impact	9	4	3	3	30
3. Methodology	9	3	4	3	30
4. Facilities	3	2	3	3	8
5. Budget	9	3	4	4	33
6. Partnerships	9	3	3	4	30
7. Awareness	3	4	3	4	11
8. Contribution	6	4	3	4	22
9. Project Management	6	3	4	3	20
10. Background	6	3	4	4	22
	315	204	213	225	217

**OVERALL TECHNICALLY SOUND**

GOOD (IF > 214)	<input type="checkbox"/>	<input type="checkbox"/>	<input checked="" type="checkbox"/>
FAIR (200-213)	<input checked="" type="checkbox"/>	<input checked="" type="checkbox"/>	<input type="checkbox"/>
QUESTIONABLE (IF < 200)	<input type="checkbox"/>	<input type="checkbox"/>	<input type="checkbox"/>

Mandatory Requirements	A1		A2		A3	
	Yes	No	Yes	No	Yes	No
Diversification Delivery:						
Project enhances the production of clean sustainable energy, to make the State a world leader in the production of clean sustainable energy, and/or to diversify and grow the State's economy.	✓		✓		✓	
Commercialization or Development/Expansion:						
Concept will lead to the <b>large-scale development and commercialization</b> of projects, processes, activities, and technologies that reduce environmental impacts and/or increase sustainability of energy production and delivery.	✓		✓		✓	
In State Requirement:	Yes	No	Yes	No	Yes	No



The funds distributed from the financial assistance are to be applied to support in-state activities and must have other sources of financial support.	✓		✓		✓	
--	---	--	---	--	---	--

- The objectives or goals of the proposed project with respect to clarity and consistency with Clean Sustainable Clean Energy Authority goals of projects, processes, activities, and technologies that reduce environmental impacts and increase sustainability of energy production and delivery are: 1 – very unclear; 2 – unclear; 3 – clear; 4 – very clear; or 5 – exceptionally clear.**

**Reviewer A1 (Rating 3)**

Much of this proposal involves enrolling farmers into the Bushel Dashboard across the nation. In the application a list of advisory team members lists one of the members as a representative from the California Air Resource Board. Being based in North Dakota, why would you not appoint a member of the Air Quality Division of the North Dakota Department of Environmental Quality to this position? The plan is to improve the air quality of North Dakota. Much of the application discussed support for out of state activities such as air quality and farmer membership in Bushel Dashboard.

**Reviewer A2 (Rating 4)**

The objectives of this proposed project are aligned with the goals and objectives of the Clean Sustainable Energy Authority. The proposed project could make the tracking of the renewable fuels full carbon input traceability much easier and could create greater value for the products of the North Dakota ag producers and the North Dakota renewable fuels manufacturers.

**Reviewer A3 (Rating 4)**

Clear connection from agriculture to carbon management using big data reserves.

- The objectives will make a difference in the near term to the state’s economy: 1 – no impact; 2 – small impact; 3 – likely impact; 4 – most likely impact; or 5 – significant impact.**

**Reviewer A1 (Rating 4)**

There is discussion regarding no-till farming as a part of the benefit, but no-till farming is already practiced in much of North Dakota. The monetary benefit that farmers are projected to receive for participation membership in Bushel Dashboard could increase income and/or reduce input costs. This could put more money in North Dakota's economy.

**Reviewer A2 (Rating 3)**

In the near term (3-5 years), this project would only have a small impact on the state’s economy. The project timeline is looking at approximately 3 years to commercialization of the final product and then there will be a period required to build acceptance and utilization in the ND Ag Producer Community. The long-term impact through the tracking and use of the dashboard data as proposed in this project could create a significant increase in crop value and could significantly increase the marketability of ND's renewable fuels in States with Low Carbon Fuels requirements.

**Reviewer A3 (Rating 3)**

Commercial viability in 36 months does not translate to economic impact immediately. Product Cycle times and market research does not show anything faster than 2 years post production, giving a 5+ year impact.

- 3. The quality and clarity of the methodology in the proposal is: 1 – well below average; 2 – below average; 3 – average; 4 – above average; or 5 – well above average.**

**Reviewer A1 (Rating 3)**

There could be more detail on how this proposal would improve the farm economy and the increase on the State's overall economic future. There could be more detail on how farmers could reduce their carbon footprint as well as how the ethanol industry could decrease their carbon footprint considering they are considered to be partners in this project.

**Reviewer A2 (Rating 4)**

The applicant has a history with the development of software products for the Ag Community and they appear to be well positioned to utilize their existing programs and their software development knowledge to complete the proposed dashboard tracking software.

**Reviewer A3 (Rating 3)**

As I own a Venture Studio, I see these type of pitches ~twice per week. This pitch is tangible, but doesn't illustrate why this dashboard is anything more complex than a SPLUNK or Alteris board based on the data already available.

- 4. The facilities and equipment available and to be purchased for the proposed pilot or commercialization strategy is: 1 – very inadequate; 2 – inadequate; 3 – adequate; 4 – notably good; or 5 – exceptionally good.**

**Reviewer A1 (Rating 2)**

There is little mention regarding facilities and equipment. Most of the discussion is centered around staffing increase for technology. Where will the 100 additional staff be housed? What type of additional equipment will be needed and at what cost?

**Reviewer A2 (Rating 3)**

In the proposed project there are no physical assets or processing equipment to be purchased; thus, there is no concern about the applicant's ability to procure the necessary equipment. The application does outline a plan for running a pilot application of the software prior to the commercialization of the program and the application goes on to detail the economics of the commercialization of the software and anticipated revenues.

**Reviewer A3 (Rating 3)**

I do believe facilities and equipment are solid, however, I don't see process (specifically training and change management) spelled out in the proposal. These will be critical for grower adoption.

- 5. The proposed budget is comprehensive and sufficient relative to the outlined work and the timetable: 1 – not sufficient; 2 – possibly sufficient; 3 – likely sufficient; 4 – most likely sufficient; or 5 – certainly sufficient.**

**Reviewer A1 (Rating 3)**

There needs to be more detail regarding salary input and equipment/facilities. There is no detailed plan for reimbursement to CSEA for any loan.

**Reviewer A2 (Rating 4)**

Based on the applicant's current business and software development history, it appears that the applicant is well positioned to execute the project and has allowed sufficient time for successful development and roll out of the product.

**Reviewer A3 (Rating 4)**

The technology architecture is not completely clear. Cyber security is much deeper than SOC2/T2 compliance. I could move to a higher number with more information on the technical details.

- 6. The appropriate strategic partnerships are in place for short and long term plans to be successful: 1 – very limited; 2 – limited; 3 – adequate; 4 – better than average; or 5 – exceptional.**

**Reviewer A1 (Rating 3)**

There appear to be some partnerships, but mostly letters of support. These come from the ethanol industry which utilizes the Bushel Dashboard to secure commodities at their plants.

**Reviewer A2 (Rating 3)**

The applicant has two letters of support from Renewable Energy entities located in North Dakota. One of the letters of support is from a well-established producer of low carbon renewable fuels and would directly benefit from a dashboard as proposed in the project and would enhance their ability to demonstrate to their markets the carbon intensity of their products.

**Reviewer A3 (Rating 4)**

Everyone is in place to be able to launch and be successful except for a strategic advisor change management team.

- 7. The likelihood that the project approach (time & budget) will achieve its technical and market goals is: 1 – not achievable; 2 – possibly achievable; 3 – likely achievable; 4 – most likely achievable; or 5 – certainly achievable.**

**Reviewer A1 (Rating 4)**

There is much work to be done to enroll farmers in the Bushel Dashboard program. Marketing will be part of the project that will help promote use of the program to those farmers to enhance farm income.

**Reviewer A2 (Rating 3)**

The project is likely to achieve the desired outcome. One potential concern is the level of support and ultimately the support from the North Dakota Ag producers. The crop producers are a key element in getting the data needed to support the value creation by this project. There was not a lot of information in the proposal as to the level of support from the farm community and the desire to purchase and track the input to make the program work.

**Reviewer A3 (Rating 4)**

Very achievable for Phase 1 at 36 months.

- 8. The scientific and/or technical contribution of the proposed work to specifically address Clean Sustainable Energy Authority goals of impacting technology used in North Dakota's energy industries will likely be: 1 – extremely small; 2 – small; 3 – significant; 4 – very significant; or 5 – extremely significant.**

**Reviewer A1 (Rating 4)**

Reduction of fuel used because of better farming practices will reduce the carbon footprint in farming, but carbon capture at the ethanol plants is a big picture that still needs to be addressed. Much of this project addresses national concerns related to farming and associated industries with mention of North Dakota farming. The Bushel Dashboard could become a vehicle to help reduce the farming carbon footprint.

**Reviewer A2 (Rating 3)**

The proposed work could have a significant impact on the value of the renewable fuels produced in North Dakota and could create additional demand for said fuels. As for the level of scientific and/or technical contribution to specifically address Clean Sustainable Energy Authority goals of impacting technology used in North Dakota's energy industries would be limited to increasing the value and potentially the demand for the fuels produced.

**Reviewer A3 (Rating 4)**

Impact over many segments and may have further expandability beyond what they are currently proposing.

- 9. The project management plan, including budgeting projections, partner connections and well-defined milestone chart is: 1 – very inadequate; 2 – inadequate; 3 – adequate; 4 – notably good; or 5 – exceptionally good.**

**Reviewer A1 (Rating 3)**

Statements include few partners, but do mention connections with those companies connected to the agriculture or ethanol industries as well as the buyers of farm products.

**Reviewer A2 (Rating 4)**

The project management plan, including budgeting projections, partner connections and milestone chart is well defined; however, the partner connection with the actual producers is a bit limited. The proposal had limited information on the development and support from the actual Ag production community.

**Reviewer A3 (Rating 3)**

would like to see a full PMBOK project management plan. This document does not spell out dependencies/resources/milestones in a standard PMP method.

- 10. The background and experience of the project principals with regards to technical qualifications and competence is: 1 – very limited; 2 – limited; 3 – adequate; 4 – better than average; or 5 – exceptional.**

**Reviewer A1 (Rating 3)**

The individuals listed in the proposal have either a farm background and/or technical experience or are connected to the ethanol/farming industry. Some of them have worked for major corporations such as Bobcat or John Deere.

**Reviewer A2 (Rating 4)**

The background and experience of the project principals and their technical qualifications and competence are well defined, and the proposed project is definitely within the scope of past products they have produced.

**Reviewer A3 (Rating 4)**

They know their space very well, but I don't have an indicator that they know the big data / data AI capacities as well.

---

**Section C. Overall Comments and Recommendations:**

**Please comment in a general way about the merits and flaws of the proposed project and make a recommendation whether or not the project is technically sound.**

**Reviewer A1**

Much of the proposal discusses benefits to farmers and corporations on a national basis. There are comments about benefits to North Dakota farmers, but a large amount of the discussion is centered around farming and associated business nationally. It is important to provide a working example from North Dakota that serves as an example to the rest of the nation's farmers and corporations.

**Reviewer A2**

Based on the information presented, the proposed project is technically sound and could create added value to renewable fuels produced here in North Dakota. The only concern is the willingness and support from the actual Ag producer. The program will be an added cost and will require a significant amount of time to track and enter the production data by the producer. The producer will not have a guaranteed return on their investment.

**Reviewer A3**

This is a solid project that I believe will do well. Many of my comments would likely be managed if we were to have a meeting on the product depth. I would like to know more about the product design and deployment, as well as the technical architecture and security plan.

Luke Swenson  
Bushel Inc.  
503 7th St N  
Fargo, ND 58103

May 18 2023

North Dakota Industrial Commission  
Clean Sustainable Energy Program  
State Capitol - Fourteenth Floor  
600 East Boulevard, Bismarck, North Dakota 58505

Dear Sir/Madam,

Enclosed is the application and supporting documents for Bushel Inc.'s application to participate in a grant proposal with the Clean Sustainable Energy Authority.

Bushel is applying for a grant to develop a technology for increasing the scale and use of differentiated commodities in the renewable fuels sector. We are excited about the prospect of partnering with CSEA on this project to help materially impact production agriculture and carbon market developments.

Sincerely,



Jake Joraanstad  
CEO  
Bushel Inc.

*Luke Swenson*

Luke Swenson  
Bushel Inc.

Clean Sustainable Energy Authority  

---

North Dakota Industrial Commission

## Application

**Project Title:** Bushel Farm Traceability Dashboard

**Applicant:** Bushel Inc.

**Date of Application:** May 18, 2023

**Amount of Request**

**Grant:** \$5,529,362

**Loan:**

**Total Amount of Proposed Project:**

\$12,265,250

**Duration of Project:** 36 Months

**Point of Contact (POC):** Luke Swenson

**POC Telephone:** (701)238-1880

**POC Email:** lswenson@bushelpowered.com

**POC Address:** Bushel Inc.  
503 7th St N  
#300  
Fargo, ND 58103

## TABLE OF CONTENTS

*Please use this table to fill in the correct corresponding page number.*

<b>Abstract</b>	<b>4</b>
<b>Project Description</b>	<b>5</b>
<b>Standards of Success</b>	<b>15</b>
<b>Background/Qualifications</b>	<b>15</b>
<b>Management</b>	<b>16</b>
<b>Timetable</b>	<b>17</b>
<b>Budget</b>	<b>18</b>
<b>Confidential Information</b>	<b>19</b>
<b>Patents/Rights to Technical Data</b>	<b>19</b>
<b>State Programs and Incentives</b>	<b>20</b>
<b>Loan/Loan Guarantee Application (if applicable)</b>	<b>-</b>
<b>Appendices</b>	
<b>CSEA Confidentiality Request</b>	<b>Attached</b>
<b>Confidential: CSEA: Project Timetable/Budget Estimates</b>	<b>Attached</b>
<b>Letters of Support</b>	<b>Attached</b>
<b>Confidential: Traceability Dashboard Business Plan</b>	<b>Attached</b>
<b>Tax Liability Statement</b>	<b>Attached</b>
<b>Confidential: Historical Financials</b>	<b>Attached</b>
<b>Confidential: CSEA Budgeted Projections</b>	<b>Attached</b>



## ABSTRACT

### Objective:

Bushel is proposing the creation of the Bushel Farm Traceability Dashboard to aggregate all aspects of farming activities to help increase adoption and production of lower carbon renewable energies. Bushel will reduce the carbon footprint of agriculture and the renewable energy sector by using Bushel's extensive network, expertise, and software platforms to enable farmers a simple path to creating differentiated, lower carbon (more sustainable) commodities.

This will be done by creating more robust integrations with existing Bushel software solutions, which are currently in use in approximately 45% of North American grain receiving facilities. Additionally, growers use Bushel software to oversee more than 100 million acres of mapped cropland today. Removing the complexity of gathering, standardizing, cleaning, and reporting on the many aspects of different lower carbon projects is one of the biggest challenges governments, states, companies, and individuals face. Bushel is uniquely positioned to tackle this in a fashion that will take others years to attempt to replicate and Bushel will be commercially available in 36 months across the country.

### Expected Results:

This project will have significant environmental and economic impacts in North Dakota and beyond.

**Environmental Impact:** Within five years Bushel anticipates software adoption by renewable energy refiners/processors will be >70%, up from +/-40% of ethanol and <10% of soybean crush today. The increase in adoption will feed Bushel's goal of over 7 million tons of carbon being sequestered annually by 2028, five years after Bushel starts development. This reflects 6% of US corn and soybean acres adopting new sustainable practices. Additionally, Bushel's project partners forecast 25-50% of renewable fuel production requiring lower carbon inputs by 2030, which would significantly exceed Bushel's modeled impact. In addition, the Bushel Farm Traceability Dashboard will be applicable to all 320 million acres of primary cropland in America.

**Economic Impact:** This project will benefit everyone from the farmers who grow commodities to ethanol and renewable diesel processors/refiners, to commercial grain entities, consumers, and the state of North Dakota. Conservative, annual revenue projections are upwards of \$25 million for North Dakota farmers and \$560 million nationwide. Revenues for processors and refiners will reflect similar results.

**Duration:** 36 Months

**Total Project Cost:** \$12,265,260

### Participants:

- Bushel Inc.
- Red Trail Energy
- North Dakota Soybean Processors
- ANEW Climate

## PROJECT DESCRIPTION

### Objectives:

What if North Dakota capitalized on the private business foundation of Bushel's digital data collection platform to unlock scalability for lowering carbon and environmental impacts for the sustainable energy and production agriculture industries in North Dakota and beyond? Bushel, Inc., a North Dakota-based company, has amassed potentially the largest digital grain and field level dataset in the U.S. over the past six years.

With its secure digital reach, infrastructure, and widespread user adoption, Bushel is uniquely positioned to provide the technology infrastructure necessary for sustainable agriculture production to scale in North Dakota and beyond. By partnering with the Clean Sustainable Energy Authority (CSEA), Bushel aims to deploy its data collection platform to empower farmers to prove out, verify, and demonstrate traceable, sustainable practices that can be utilized to produce differentiated grains for renewable energy refiners and processors.

Bushel will develop the “Bushel Farm Traceability Dashboard” to change the landscape of low carbon agricultural and renewable energy production. This dashboard will be built into the already existing *Bushel Farm* farm management software platform.

Historically, the procurement, tracking, and profitability of sustainably produced inputs have posed significant challenges for renewable energy refiners as farmers aren't properly equipped or incentivized to adopt sustainable, lower emissions practices. Tracking field level information is difficult for the farmer. Additionally, providing a program that requires a high level of administration is taxing on the grain buyer. Bushel's solution helps both parties connect with the right data in real time. Efficient administration of data collection, aggregation, standardization, and distribution will provide adoptable, premium solutions for sustainably produced energy products, and help reduce agricultural and renewable energy emissions. To effectively monetize changes in inputs for sustainable and renewable energies, as well as sustainable foods, we must address the monetization and existing heavy burden of change management aspects for farmers.

The United States and global economy are driving demand for sustainable energy. They are being led by both states and industry with the likes of California driving the narrative, while the federal government tries to catch up with plans around how to help carbon markets succeed. We are rapidly approaching a crossroads where hundreds of millions of tons of carbon reduction will be necessary each year, yet the supply is woefully insufficient to meet those needs. The agriculture industry, more than any other industry in the developed world, is well positioned to help reduce carbon footprints and effectively market and monetize the results of collective sustainability efforts.

To compound the situation, many companies, cities, regions, and individuals have made pledges to reduce their respective carbon footprints in the coming years. Some aim to achieve this by 2025, while

many more have set targets for 2030. Shockingly, more than two-thirds of the largest 2,000 publicly traded companies that made such pledges have no roadmap to reduce their carbon footprint.

This presents a significant market opportunity for new products and revenue generation, unlike anything seen before in agriculture or energy production. Just as the shale revolution reshaped fossil energy production in the US, the carbon and sustainability needs of our economy are now reshaping agriculture. This opportunity allows both industries to collaborate and achieve rapid scale adoption in a way that benefits them mutually.

Bushel's proposal seeks to bridge the gaps in the supply chain, facilitating faster and more efficient market growth to meet the increasing demand for sustainably sourced grains. By doing so, we will enhance the capacity of renewable energy processors and refiners to produce premium sustainable energies that can meet the world's needs while drastically reducing the carbon footprint of both renewable energy and agriculture. We will do this from a position of helping farmers be incentivized for their change in practice, rather than legislative action. This is how the industry can shift to meet the carbon sequestration needs coming from corporations and states in the coming years.

By combining Bushel's existing software platforms with further development, the company envisions enabling renewable energy refiners to create premium sustainable energy solutions using more sustainable agricultural practices while increasing revenues throughout the supply chain. Currently, Bushel has connected approximately 2,400 grain elevator/processor locations through its platform, engaging over 100,000 farmers, and mapping more than 110 million acres of fields. In our home state of North Dakota we have over 100 elevator/processor locations using Bushel with their farmers and over 4,000 more farmers specifically using Bushel Farm. Over the past decade, Bushel has invested over \$100 million in its products, with \$37 million dedicated solely to the development of the Bushel Farm platform, which will specifically house the Bushel Farm Traceability Dashboard.

Leveraging its North Dakota headquarters and existing network, Bushel aims to create a user-friendly, permission-enabled, and secure digital interface within the next 24 months. Bushel will enable farmers to confidently track and market differentiated commodities to existing and future renewable energy refiners. The commercialization effort will coincide with the development process, utilizing Bushel's network, dedicated staff, and industry representatives to drive adoption and awareness of the market potential for premium, lower carbon renewable energy products. This project will make a significant impact on North Dakota in the near term and will expand to all American farmers.

One of the challenges in monitoring and reporting greenhouse gas emissions (GHGs) and carbon sequestration lies in the need to collect and manage data from as many as 10-20 disparate systems. These data sources include proof of yield reports, crop inputs, field-level activities, soil samples, storage activity, and more. Bushel recognizes the significance of developing a streamlined and comprehensive sign-up/management system that handles this information. If chosen to advance this pivotal technology within the state and the country, Bushel is committed to pursuing the project alongside the CSEA and other projects. Given Bushel's unique position at the intersection of data, technology, and sustainability, the company is best suited to tackle the complexities of this opportunity.

Bushel possesses a unique set of capabilities that positions us as a leading force to address the immense challenges associated with carbon reduction. Our extensive reach and expertise enable us to undertake a project of this scale with confidence. The economic impact of our Dashboard will be just as significant as the environmental impacts. From farmers to refiners, the change in ease of adoption and monetization will have far reaching implications to renewable energies and reducing the carbon footprint of energy and agriculture in North Dakota.

### Methodology:

The value of this dashboard is that unlike many sustainability projects that point to a single methodology, Bushel is creating technology that can house, facilitate and support any existing and future methodology. This means the best projects available today, and the highest quality, scalable methodologies of the future can seamlessly scale on Bushel’s network. That is something exclusive to Bushel and its reach across American agriculture. Think of Bushel as the interstate upon which the sustainability data will reside. Bushel can be the catalyst for adoption in a location where the farmers and industry trust their data to reside, and be used to create value.

Starting from the farm gate, Bushel is able to support the adoption and success of all existing and future methodologies, achieving scale and impact throughout the entire supply chain. This is unseen in American agriculture today. There is no other company that has the field level reach, grain accounting data points, and farmer adoption of digital tools. Bushel's technology is designed to enable market participants to adopt and scale sustainable practices, both today and in the future with significant ease compared to older existing methodologies/projects. For baseline sake of argument, we have utilized a simple methodology from the University of Nebraska Lincoln focusing on cover crops and no-till. As a baseline for result assumptions in this proposal, the programs integrated into our flexible platform will likely vary by region. Different regions may adopt diverse practices such as low carbon fertilizer, no till, strip till, cell grazing, cover crops, water management, double cropping, natural fertilizer, and more.

The proliferation of sustainability programs in the US has led to a heavy reliance on multiple metrics that are present in many programs, ranging from field-level data on tillage and fertilizer practices to logistical metrics such as the distance grain travels before processing. However, the fragmented and incomplete nature of available data often hinders the creation of new markets. This is where Bushel is unique: Bushel has brought together disparate datasets that have the ability to unlock new revenue for both farmers and grain facilities/processors.

To address this, issue Bushels brings together commercial industry activity and all of the farmer's field activities. This creates a “super scale ticket” for the grain buyers our farmers sell to, enabling them to

confidently know they have bought a true, low carbon differentiated commodity. Our rapid growth has made Bushel one of the largest

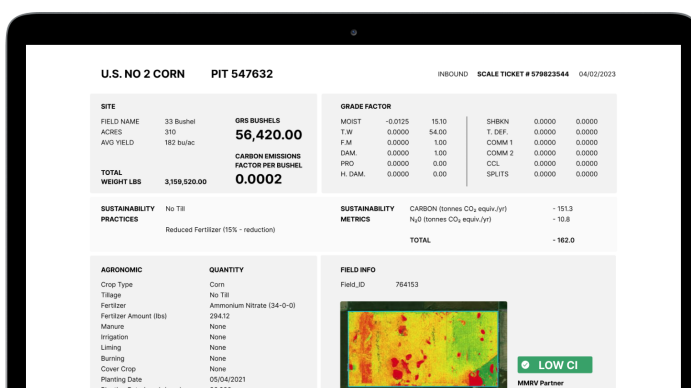

repositories of farmer field activity data globally, combined with all delivery, contract, and quality metrics. While our connections were initially established to streamline transactional business with elevators, they have inadvertently created a pipeline that enables the true marketability of sustainably sourced agricultural products and traceability.

Although sustainability reporting was not our original plan, Bushel is now just a few steps away from being able to handle all the activities necessary to validate and transfer all relevant data for sustainable practices from the farmer to the end of the supply chain. The availability of our datasets can support existing sustainability initiatives within the industry and facilitate the easier creation and scalability of future low carbon energy products. We can further assist by leveraging our extensive network in the grain space to facilitate partnerships between end-users and the industry in developing future product methodologies.

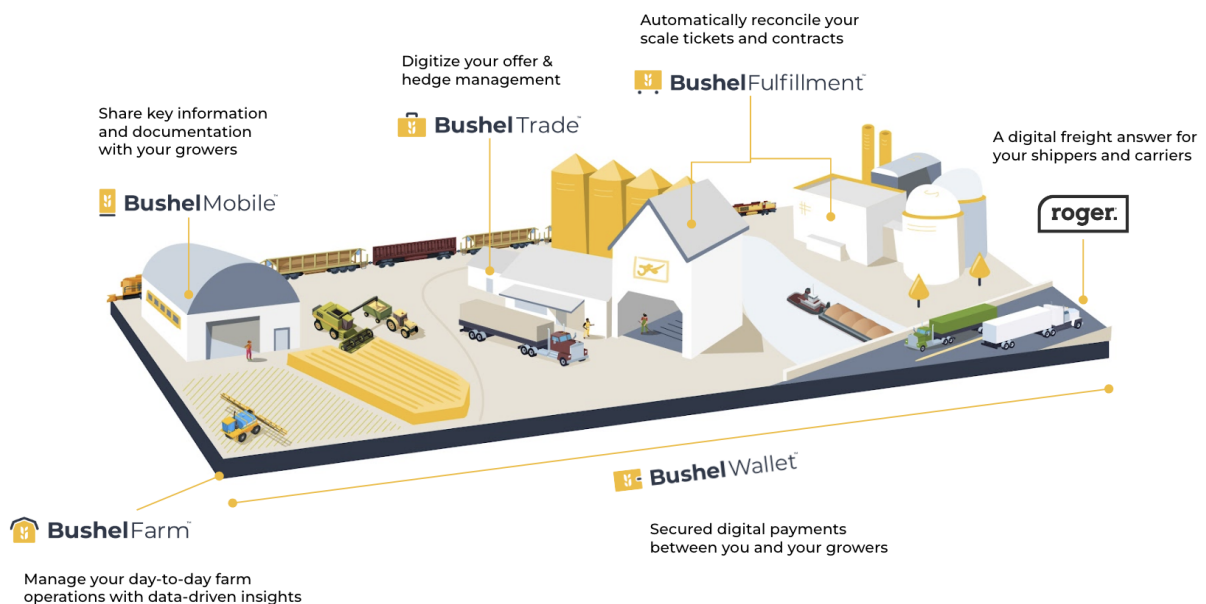

In addition to benefiting the renewable energy sector, the Bushel Farm Traceability Dashboard can also aid other industries such as food, livestock, low carbon coal power, etc. With new North Dakota legislation allowing large-scale livestock production in North Dakota, our platform can help monitor power usage and emissions in those facilities. This would enable a dairy to accurately source low carbon corn, DDGs, and alfalfa, and potentially consume low carbon captured coal power off of Minnkota Power Cooperative's transmission from Project Tundra. Resulting in some of the lowest carbon footprint dairy products accessible in the world – and it works for all confinement protein sources.

Through a strategic alliance with Anew Climate and other key stakeholders in the sustainability markets, Bushel is uniquely positioned to drive the creation, adoption, and success of new projects more effectively than previously possible due to the existing fragmented systems in place. By leveraging our

integrated platform, Bushel has the capacity to enable the implementation of innovative methodologies from various market participants, thereby fostering greater adoption of sustainable practices.

What sets us apart is the significant support we have garnered from companies like Anew that have traded over 600 million tons of emissions credits individually. This substantial backing underscores our commitment to facilitating the adoption of current and future methodologies, ensuring a comprehensive approach to sustainability.

With Bushel as the catalyst, revolutionizing the sustainability landscape and empowering diverse stakeholders, we are paving the way for a more cohesive and impactful future. The Bushel Farm Traceability Dashboard holds immense potential to transform multiple sectors, enabling sustainable practices, driving market development, and generating positive environmental impact. By embracing this innovative solution, we can usher in a new era of sustainability, creating a more resilient and prosperous world for generations to come.

#### **Anticipated Results:**

In 2020, the agriculture sector alone accounted for approximately 670 million metric tons of carbon dioxide, representing 11.2% of total US emissions. Transportation contributed 27.3%, while industry accounted for 30.3% of emissions. With the Traceability Dashboard operating at scale, the agriculture sector has the potential to make significant changes to this distribution by incentivizing practice changes and supporting renewable fuels initiatives. Bushel's goal is to reduce agriculture's footprint faster than any other segment of our economy.

When looking at the net outcome environmentally, we have to pick a baseline methodology for our dashboard to compare against. Success means the adoption of any sustainable practice. Bushel will specifically reference The Carbon Farming analysis conducted by the University of Nebraska Lincoln which has shown that implementing practices such as no-till farming and cover crops can result in an average sequestration benefit of 0.76 metric tons per acre per year. Although these practices may not be universally applicable to every field or farmer, there are various opportunities to make sustainable adjustments in different regions of North Dakota and the entire country. If you extrapolate broad findings like this across the breadth of the US you can see the potential benefits. If region specific practices resulted in that same level of sequestration, you could see upwards of 200 million tons of carbon sequestration per year across the approximately 320 million acres of primary grains in the US. Flexible, scalable technology such as our proposed Traceability Dashboard enable the market to achieve reductions of this magnitude, and allow agriculture to make some of the largest and quickest adjustments to meet future carbon requirements. Bushel Farm's Traceability Dashboard will enable farmers to better realize the returns on their practice changes. The need for a solution that accounts for all crops, not just renewable energy inputs, means that even during off rotation years those farmers can continue to reap the benefits of their sustainable activities.

Consequently, this will enable North Dakota to continue its progress toward becoming the first carbon-neutral state in the country. Our goal is to have 10 million acres administering new sustainable practices by 2028, sequestering (or reducing) approximately 7.6 million tons of carbon per year. This can be accomplished in North Dakota alone with a strong launch and market support.

From a financial perspective, the opportunities are equally significant. Our approach is to create scalability at the farm gate and extend that to consumers led by the opportunity of market value monetization. Based on CARB's data, the potential value for lower carbon corn/beans at the farm gate ranges from 10 to 40 cents per bushel. If the US renewable industry were to scale to using 50% low carbon differentiated grains by 2030, the revenue increase for farmers would exceed \$25 million in North Dakota and \$560 million across the US annually. These estimates assume a conservative premium of only 15 cents per bushel for farmers. The actual premium to meet the demand when 2030 corporate obligations arrive is likely to be much stronger.

The net result of Bushel Farm's Traceability Dashboard is that renewable energy processors will have a direct, digital pathway to access the necessary data for procuring differentiated grains, enabling the creation of lower carbon fuel products at renewable energy refining facilities on a large scale. This data will empower corn/soybean processors and grain buyers to confidently offer premium prices for sustainably sourced commodities, thus increasing supply and options for consumers. This project holds significant potential for farmers not only in the US but also across the world.

#### **Facilities:**

Development for this project will be led by Bushel Inc., headquartered in Fargo, North Dakota. While our partners and supporters span across the country, we believe it is essential to begin piloting our tools with companies based in North Dakota. Our initial focus will be on demonstrating the value of our solutions in multiple sectors, starting with ethanol and renewable processors within our state.

We are thrilled to have the support and participation of **Red Trail Energy**, a leading sustainable energy producer. They have expressed their commitment to pilot our dashboard and are eager to potentially become the first carbon-negative ethanol facility in the country. Their letter of support is attached, highlighting their enthusiasm for our project.

Additionally, **North Dakota Soybean Processors** has agreed to pilot the Bushel Farm Traceability Dashboard. NDSP will own and operate a new soybean processing plant expected to begin operations in Summer 2024. NDSP has also agreed to provide a letter of support for our project and the value it would bring.

From an energy and food ingredient perspective, **The Arthur Companies** has already stepped forward and expressed their interest. Their milling venture in the Pacific Northwest is already experiencing

significantly monetized demand for the solution that Bushel is offering within this project. Also being a future supplier to NDSP, they see the synergies and support for each other.

Through collaboration with partners like **Anew Climate**, Bushel can leverage its consolidated data set to uncover and develop new carbon methodologies and projects that were previously impossible due to the challenges of aggregating essential datasets. This partnership enables the acceleration of market evolution, surpassing the pace witnessed thus far. By combining our forces, we can catalyze the emergence of innovative initiatives and propel the carbon space towards unprecedented growth and impact.

**Dr. Dave Ripplinger** from North Dakota State University has been helpful in an advisory capacity, and will continue to assist as we progress with this project and encounter many challenges and opportunities as the emissions and renewable fuels markets evolve in the coming years.

We are grateful for the enthusiastic response from these organizations, all of whom eagerly embraced the opportunity to participate in our project. Their support and involvement will be invaluable as we advance and demonstrate the effectiveness of our solutions. With strong domestic investment in ethanol, bean processing, and refining, North Dakota has top tier facilities, infrastructure, and intellectual capital for a project such as this.

**Resources:**

The value added by Bushel's existing network is rooted in its expansive reach, boasting over 2,500 locations nationwide that serve as direct farmgate buyers. Moreover, our products foster direct interactions with over 100,000 farmers. This network encompasses several prominent grain buying entities in the country, including many within the top 20 grain traders, offering valuable testing opportunities for all aspects of our Traceability Dashboard and future applications.

In addition to our project partners, pilots, and advisors, we will engage various other parties to bolster our project. Our core development team will be based in Fargo, benefiting from the comprehensive expertise of Bushel's development teams. To meet our staffing requirements, we will combine new hires with specialists from other areas of Bushel as necessary. Once the project is underway, we will assemble a dedicated team in collaboration with our existing Bushel Farm team.

Furthermore, we have established relationships with retail agricultural companies, land grant institutions, researchers, economists, lobbyists, regulators, and more. These connections will play a pivotal role as we navigate the different phases of the project, offering support, expertise, and guidance.

We are excited to have Anew Climate as a partner as the largest developer of environmental attribute projects in North America. Their storied history going back decades will be helpful as our dashboard takes shape. With the ability to develop new projects as industry and consumer demands change and emerge, they will help increase adoption even more rapidly when commercialization occurs.



Some of our partners may take on specific tasks or contribute to certain project components, utilizing our shared funding to develop elements that may not fall directly within Bushel's purview or to facilitate the commercialization of products and methodologies moving forward. These partnerships may involve:

- Cross-industry committees for research, input, and oversight on our development.
- Collaborative efforts with Land Grant Institutions to create and support methodologies for potential differentiated commodity products.
- Collaboration with Market/MMRV/Trading companies to develop and commercialize new methodologies using the foundation of Bushel's Traceability Dashboard, overcoming previous challenges in commercialization.
- An industry advisory committee as our Traceability Dashboard comes to fruition.

### Techniques to Be Used, Their Availability, and Capability:

From a development perspective, our team already comprises nearly 100 full-time software developers who have been instrumental in building the technologies that have brought us to where we are today. For our sustainability push, we will expand this team while maintaining the same commitment to quality software development that our customers have come to expect. As a secure software company dealing with data, money movement, and privileged confidential information, we adhere to SOC 2 compliance standards, ensuring that every aspect of this project, from design to development to security, is held to the highest standards.

We will leverage Bushel's significant investment in our two core products directly. The APIs between the commercial entities and farmers will play a crucial role in every step of this project. Bushel Farm, our farmer-facing farm management software, will serve as the host platform for the Traceability Dashboard. Developing the Traceability Dashboard will require a diverse range of developers, including front-end developers, UX/UI experts, graphic designers, back-end coders, Q/A specialists, marketing professionals, branding experts, and more. We will draw from the playbook that has already proven successful with our existing customer base.

Bushel's extensive connections and network will be utilized to seamlessly integrate field-level data, grain contracts, deliveries, and all necessary parameters with the processing facilities. This will enable efficient and paperless management of all records in the production of these lower carbon and more sustainable energies.

Our partners, carbon market participants, MMRVs (Measurement, Monitoring, Reporting,

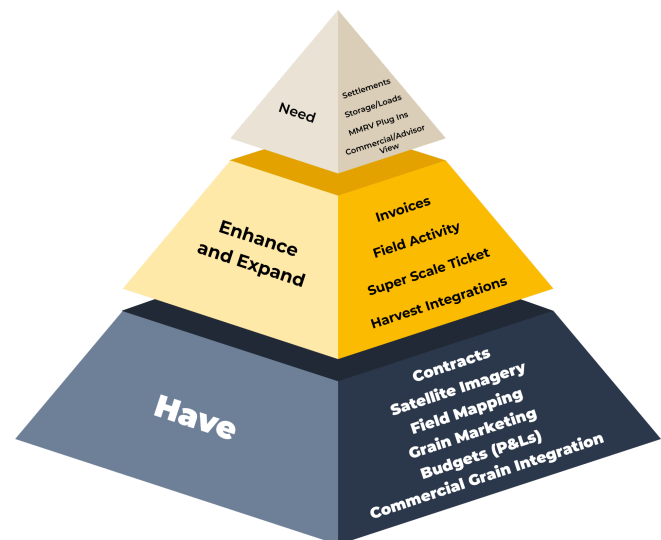

and Verification), and other yet-to-be-named collaborators will connect to Bushel's APIs for authentication and to store the relevant data, attributes, and certifications related to the grains and renewable energies created. Purchasers, and those in the supply chain buying differentiated commodities, will have access to this information as well through our new advisor/commercial view.

### **Environmental and Economic Impacts while Project is Underway:**

During the initial 24-month phase of this project, the environmental impacts will be limited to farmers and land directly involved in the pilot process. All field data will be tracked through Bushel Farm. Once the connections are established (estimated to be early 2025), we will commence co-marketing the opportunities and scalability of these results alongside Bushel Farm's new Traceability Dashboard.

By the start of the 2025 growing season, we anticipate that commercialization efforts will be in full swing and the potential of the Traceability Dashboard will become increasingly evident. This significant milestone will not only generate additional revenue for participating farmers but also mark the inaugural season of lower carbon sustainably produced agricultural products that can be scaled and marketed through the renewable energy pipeline.

### **Ultimate Technological and Economic Impacts:**

The current Carbon Accounting process in various industries is extremely fragmented, involving disconnected parties and cumbersome paper-based systems, along with laborious support, audit, and verification processes. Our ultimate objective is to revolutionize the agricultural industry's ability to process and report in real-time by developing a paperless, digitally permissioned reporting system that is instantly adaptable to unlimited market changes and opportunities. As the carbon and sustainability markets continue to evolve, our adaptable toolset will meet the changing parameters.

Through our Traceability Dashboard, we not only support existing specialty products and processes but also facilitate faster market evolution, providing unmatched ease compared to competing products. The economic impact of our solution extends beyond our state or country and has global scalability. Once commercially launched on a broad scale, our solution has the potential to significantly increase farmers' revenues nationwide. According to estimates by CARB, farmers in North Dakota could generate \$30-50 per acre in additional revenue. By 2025, North Dakota is projected to produce over 500 million gallons of ethanol and renewable diesel annually from corn and soybeans. Introducing a scalable option for farmers to monetize their sustainable practices and sell premium products could potentially generate over \$50 million per year for our state's farmers. Additionally, by capturing a 10 cent per gallon premium on sustainable fuels, refiners in North Dakota alone could gain an additional \$50 million in revenue.

These estimates focus solely on the impact within North Dakota, but when expanded nationwide, the multiplier effect becomes even more significant. Increasing the value of corn and soybeans to processors

by just 15 cents per bushel (with estimates suggesting that lower carbon inputs can be worth upwards of 40 cents more per bushel according to CARB) would result in an annual revenue increase of \$1.15 billion for US corn and soybean producers. Similarly, applying this to the national scale of our 20 billion gallon ethanol and renewable diesel markets, a 10 cent per gallon increase in the value of the fuel created translates to an additional \$2 billion in revenue annually.

Furthermore, this proposal only scratches the surface of the value derived from other areas of monitoring and enablement, such as livestock, grain for food, feedstock, and monitoring agriculture-related energy use. The second-order effects of this project have the potential to redefine agriculture and create new revenue opportunities for decades to come.

### **Why the Project is Needed:**

With the increasing focus on carbon reduction, discussions about the need for change have intensified. However, scalable opportunities that can effectively incentivize a shift in practices are lacking. The United States is rapidly approaching a critical point in supply and demand, and our existing infrastructure is ill-prepared for this challenge. Surprisingly, despite more than one-third of the largest 2,000 publicly traded companies committing to significant carbon footprint reduction by 2025 or 2030, over two-thirds of these companies lack a concrete plan or strategy to achieve these goals. Many of these corporations lack a solid understanding of production agriculture and how our technology can assist them in achieving their objectives.

Considering Bushel's proven success in other areas of agriculture and data, we believe this is the most promising investment opportunity for CSEA in this biennium. By leveraging our market reach and addressing the sustainability needs of our state, corporations, and country, Bushel is well-positioned to assist all stakeholders involved.

Given the United States' prominent role in renewable fuels production and the imminent revolution in renewable diesel, no industry is better positioned than agriculture to make a significant impact on carbon reduction. To fulfill the objectives of these corporations, it is crucial to incentivize the production of American commodities such as corn, soybeans, and other grains while establishing robust systems to monitor and track their sustainable attributes.

Although niche products have emerged and achieved limited success in the market, there has yet to be an infrastructure with comprehensive market-making capabilities that can truly establish a scalable market for the industry's success. This is precisely where Bushel, along with CSEA, our customers, network, and partners can surpass previous attempts and drive the industry forward.

## **STANDARDS OF SUCCESS**

The primary objective of our project is to enable farmers and renewable energy processors to effectively monetize the adoption of widespread sustainable practices, thereby reducing the carbon footprint of agriculture and energy, while increasing revenue for farmers and the renewables industry. To date, farmers have faced challenges in embracing, reporting, and deriving value from differentiated commodities within the sustainability revolution.

By providing the market access to an agnostic tool that is able to collect, store, and disseminate data to any parties with secure data-permissioning, Bushel will enable market participants to adopt and scale sustainable practices. Additionally, we will also increase the market's ability to evolve quickly, attract, and create new practices, methodologies, and ideas. This feeds directly into our state's goal of carbon neutrality and makes it all the more attainable.

The ultimate measure of success for this project is whether Bushel has successfully developed and implemented a scalable platform that encompasses the necessary functionality to track, monitor, and facilitate the sale of differentiated commodities across diverse platforms, products, and suppliers.

To consider this project a success internally, Bushel aims to have over 10 million acres in Bushel Farm actively engaged in differentiated commodity reporting by the 2028 marketing year. This adoption would translate to an estimated sequestration of 7.6 million tons of carbon that year (based on a University of Nebraska Lincoln study on carbon farming), yielding significant ripple effects on Bushels revenue and subscription base.

The public and private sectors will both benefit from our finished Traceability Dashboard as the increase in the market for carbon offsets, differentiated commodities, and easier movement of data will enable all participants to increase participation, liquidity, and motivation around sustainability.

With such widespread adoption, there would be no limit to the scalability of Bushel Farm, as it could accommodate any number of acres moving forward. We firmly believe that the combination of our product and the growing market for sustainable renewable energies has the potential to revolutionize traceability in agriculture on a global scale.

## **BACKGROUND/QUALIFICATIONS**

Our leadership has often joked 'had we known the effort it would take to build what we have built... Bushel might not have ever started.' The effort behind perfecting data integrations and data standardization across the continent has been arduous, but rewarding. Over the past 7 years, Bushel has scaled from 40 employees to over 200 employees today. Our Fargo-based team has proven itself time and again through our dedication and continued success.

Bushel's leadership team comprises individuals from various backgrounds, each with a strong agricultural history. Chief Technology Officer, Randy Gerhold, brings extensive experience from Microsoft, overseeing large-scale software projects. Co-founders Jake Joraanstad and Ryan Raguse have deep agricultural roots, growing up near Rolla and the Red River Valley. Chief Growth Officer, Michael Sharov, brings decades of expertise from John Deere, Granular, and Caterpillar, including his role as head of product strategy. Camille Grade, Chief Market Officer, is renowned for her branding, adoption, and visionary skills. The rest of Bushel's team possesses diverse experience in ag-tech, integrations, M&A, and software sales. We believe our leadership team represents the most well-rounded group in agri-tech today.

Bushel has integrated with 15+ different agriculture accounting platforms and an infinite number of variations within them which is something unmatched in the agtech industry. That effort and expertise has allowed Bushel to reach a scale of data and service to the industry that wasn't previously possible. Of the top 20 grain companies in the US, Bushel has relationships with over half of them – and more coming online each month.

Bushel works with some of the biggest agriculture companies in North America to help them solve problems through the effective deployment of software solutions. These customers include, but are not limited to: Cargill, Archer Daniels Midland, Consolidated Grain and Barge, The Andersons, AB In-Bev, Koch Industries, Bobcat, Ingredion, Animal Health International, Roger and, many more.

## **MANAGEMENT**

Bushel has extensive experience in managing large-scale custom projects for our own software as well as third party-customers. In a similar fashion, we will monitor and stage investments from CSEA, working in focused teams with project managers, developers, and executive oversight to ensure progress, manage hurdles, and prevent scope creep.

Our Quarterly Planning and Alignment meetings will be the major planning ground each quarter, complemented by smaller sprints within these periods, enabling our teams to flex and focus depending on the specific needs of each project point. Monthly reporting documents will be submitted to CSEA, providing specific data points for each project.

One of the advantages of partnering with Bushel is our efficient structure, which enables us to avoid wasted time on full-time employees. We can flexibly allocate resources across various types of domain expertise (software developers, graphic designers, project managers, etc.) without experiencing any latent time in our schedules. As a result, this will reduce the overall cost of creating the Bushel Farm Traceability Dashboard.

To prevent scope creep in spending and better protect North Dakota's investment, we will hire a Senior Project Accountant so that we go above and beyond for reporting and monitoring our state's valuable capital.

To ensure maximum effectiveness and promote collaboration across various sectors, Bushel has a strategic plan in place to establish an inclusive and diverse advisory team. This cross-industry committee will play a vital role in shaping the project, ensuring that the perspectives and insights of all relevant stakeholders are taken into account. The objective is to develop a highly adaptable, reliable, accessible, and secure platform that meets the needs of all market participants.

Outlined below is a hypothetical breakdown of our preferred committee, reflecting a wide range of stakeholders from different sectors. This diverse composition will provide a comprehensive and well-rounded view:

1. North Dakota State University (Production Agriculture/Renewable Energies)
2. UND (University of North Dakota) EERC (Energy & Environmental Research Center)
3. Bio-Refiners and Processors (Ethanol/Renewable Diesel)
4. Fossil Fuel Industry (Coal/Oil & Gas Representative)
5. Regulatory (CARB - California Air Resources Board)
6. Independent Representative (Financial/Regulatory Sector)
7. Agricultural Representative (Farmer)
8. Governance (BND/State of North Dakota)

Bushel has always believed that better products are created by diverse, broad-reaching contributions. This collaborative approach will foster innovation and efficiency across industries, enabling the project to make a meaningful, sustainable, and lasting impact.

## **TIMETABLE**

A project-by-project outline is provided as a separate appendix to this proposal titled: *Confidential: CSEA: Project Timetable/Budget Estimates*. Bushel will provide quarterly planning outlooks and regular updates as we advance through each independent objective within this overall proposal. These reports will be shared with CSEA following our Quarterly Business Review process, which all of our development teams follow for reviewing the previous quarter's activities.

While a significant portion of the project involves integrations, security, and API development, we anticipate the visible results to be delivered in the following sequential manner as we progress through the development stages.

Q3 2024: Farmers will have the ability to import most, if not all, their field-level activities directly into their Bushel Farm account from the top 10 necessary Machine Data integrations. We will also enhance the robustness and cost-effectiveness of our backend connections.

Q1-Q2 2025: Growers can permission their information to be shared through the Traceability Dashboard, handing buyers the needed sustainability metrics with which to create their low carbon test batch. Pilot

processors can conduct a 'test run' of specific grain data through their system. Success in this milestone will launch our overall commercialization and marketing strategy, targeting buyers across North America.

Harvest 2025: We anticipate producing and selling our first commercial batch of renewable, lower carbon fuel to an end user from one of our pilot facilities.

2026: Farmers will have the ability to consider and adjust their growing practices on a broad scale to meet the specific grain buying entities' product options. Our commercialization team, along with our MMRV and registry partners, will vigorously pursue and adopt products and processors into Bushel, further expanding the market for these renewable, sustainable differentiated commodities.

Our commercialization team, MMRV, and registry partners will be full-scale pursuing and adopting products and processors into Bushel to continue increasing the market for these renewable, sustainable differentiated commodities.

**BUDGET**

*This is the Summary Budget, more details into the use, staffing and allocations are broken out in our attached appendix: **Confidential**: CSEA Project Timetable/Budget Estimate*

Project Associated Expense	NDIC Grant	NDIC Loan	Applicant's Share (Cash)	Other Project Sponsor's Share	Total
Software Development	\$3,702,600		\$4,525,400		\$8,228,000
Pilot Program	\$440,100		\$537,900		\$978,000
Marketing Allocation	\$553,162		\$676,088		\$1,229,250
Commercialization Plan	\$823,500		\$1,006,500		\$1,830,000
<b>Total</b>	\$5,519,362		\$6,745,888		\$12,265,250

## CONFIDENTIAL INFORMATION

We have attached the confidentiality request document, which outlines the sensitive nature of the attached appendices and emphasizes the need for their security. We kindly request that the following items, be treated as confidential due to the competitive and protectionist nature of agri-tech, the emissions markets and associated technologies:

1. Project Timetable/Budget Estimates
2. Business Plan
3. Historical Financial Statements (these will be shared directly with the Bank of North Dakota)
4. Budgeted Projections

These materials contain crucial information regarding our competitive advantage, encompassing our strategic direction, speed, and partnerships. Particularly, our planning efforts for the development of our Dashboard, interconnected products, and go-to-market strategy are at a high risk of theft and replication. Therefore, it is of utmost importance that the confidentiality of these documents is maintained.

## PATENTS/RIGHTS TO TECHNICAL DATA

*Any patents or rights that the applicant wishes to reserve must be identified in the application. If this does not apply to your proposal, please note that below.*<sup>8</sup>

*Bushel reserves all rights under its pending or granted patents*

- *Commodity tracking system and method* 16/100,129
- *Blind commodity marketplace* 16/542,937
- *BLIND COMMODITY MARKETPLACE* 2019321690
- *BLIND COMMODITY MARKETPLACE* 1120210029214
- *Qualitative commodity matching* 17/569,271
- *BLIND COMMODITY MARKETPLACE* PCT/US19/47065
- *User interface for adjusting component proportions* 17/730,141
- *Computer display screen with component proportionality element* 29/845,734
- *Commodity Tracking System and Method* US 11,100,579
- *System and Method for Field Variance Determination* US 9, 734,400
- *SYSTEM AND METHOD FOR REMOTE NITROGEN MONITORING AND PRESCRIPTION* US 9,652,840
- *System and Method for Crop Health Monitoring* US 9,638,67



## STATE PROGRAMS AND INCENTIVES

*Here is a list of all state programs that Bushel has participated in during the past 10 years we have been in business.*

- **Operation Intern North Dakota Department of Commerce Workforce Development**
  - 05/31/2021-06/01/2022 = \$14,648.30
- **Legacy Investment for Technology Loan Fund (LIFT)**
  - 06/08/2020 - 06/08/2027 = \$1,000,000.00
- **North Dakota Jobs Credit**
  - 01/22/2013 - 01/22/2023 = \$519,619.21
- **North Dakota Development Fund Loan**
  - 12/08/2017 - 01/01/2022 = \$500,000.00
- **Bank of North Dakota New Venture Capital Loan**
  - 12/08/2017 - 01/01/2022 = \$300,000.00
- **Growth Initiative Fund Loan**
  - 12/08/2017 - 01/01/2022 = \$300,000.00



To Whom It May Concern:

We're writing today in support of Bushel's proposed development of the Bushel Farm Traceability Dashboard, and to underscore the material impact Bushel's technology can have in facilitating the broader adoption of Climate Smart farming practices across American agriculture.

Bushel's ability to reach nearly every corner of the US market through technology and data capture is impressive, and their strong relationships between both farmers and the commercial grain industry sets them apart.

Anew is the largest developer of environmental attributes in North America, has a history going back several decades, and provides turn-key project development solutions that incent agribusinesses and growers to adopt and maintain Climate Smart farming practices.

Anew is excited about the prospect of collaborating with Bushel; and our companies look forward to collaborating in ways which leverage Anew's core competencies of developing innovative solutions that help drive the adoption of Climate Smart farming practices via broad utilization of Bushel's proposed Bushel Farm Traceability Dashboard.

Anew recognizes the legislative, regulatory, and financial landscape for Climate Smart farming practices is rapidly evolving. We have demonstrated over our history to be ready, willing, and able to help drive impactful environmental change across other market segments and have an analogous vision for agri-carbon. We believe Bushel is the right platform partner to help us achieve this vision.

The Bushel Farm Traceability Dashboard has a laudable goal: to reshape the adoption, trade, and utility flow of sustainable commodities around the world and thereby create an ecosystem of greater traceability and integrity in commodities markets. By integrating within this ecosystem, Anew is committed to leveraging its immense commercial capacity of environmental attribute development and marketing to further incent the adoption of Climate Smart farming practices. In so doing, our companies intend to do our part to help make American supply chains more resilient, the American farm more sustainable, and take meaningful steps to help mitigate greenhouse gas emissions in agriculture.

We respectfully request the fullest consideration be given to Bushel's proposal. The positive environmental and economic impact potential are material, and we believe it is a proposal worth serious consideration.

Respectfully,

Anew Agri-Carbon



# The Arthur Companies

PO Box 145, Arthur, North Dakota 58006-0145    [www.arthurcompanies.com](http://www.arthurcompanies.com)    701.997.6101    fax 701.364.5434

May 17, 2023

At The Arthur Companies we are excited about innovating to help the North Dakotan farmer prosper. We feel that Bushel's new tool will help us unlock value from consumer products manufacturers. This tool will help the farms readily adopt lower carbon practices and enable us to communicate efficiently those practices to the consumer and manufacturing sectors. This leads to more premium for the farmer. There is a growing demand for lower carbon cropping practices and soil health management. This tool allows farmers to simply track those activities and helps monetize them.

We believe the dashboard will be valuable to providing our milling business and we see it adding significant value to the grain we procure, sell and fertilize. Our food and renewable energy customers are excited to find an efficient manner to equip the farmer to record this practice. With dramatic emissions goals this will assist in an "all of the above" mixing energy policy and agriculture. It engine of our great state.

Sincerely,

Kevin Karel  
General Manager  
The Arthur Companies



# RED TRAIL ENERGY, LLC

“Our Farms, Our Fuel, Our Future”

---

PO Box 11 Richardton, ND 58652 (701)-974-3308 FAX (701)-974-3309

---

May 17, 2023

Luke Swenson,

At Red Trail Energy, our relentless pursuit is to become the first carbon-negative ethanol plant in the country. We have made tremendous strides towards this goal, and now we see a significant opportunity through the Bushel Farms Traceability Dashboard. This platform has the potential to unlock increased production opportunities for differentiated low carbon feedstock, which is crucial for our plant's operations in the developing low carbon marketplace.

The demand for low carbon requirements is growing rapidly, and our customers are becoming increasingly concerned about the future supply potential. That's why we are thrilled about the possibility of piloting the Bushel Farms Traceability Dashboard. If CSEA cooperatively funds this development, it has the potential to revolutionize production agriculture and renewable energy by incentivizing true change in carbon emissions and traceability concerns for all North Dakota and American farms.

We wholeheartedly endorse this proposal as one of the most compelling opportunities we have encountered in the past five years of carbon and sustainability conversations. It has the power to drive tangible change in the production agriculture space and create a lasting impact.

Sincerely,

Submitted by: AIC Energy Corp.  
 Project Duration: 24 months  
 Total Project Costs: \$525,000,000  
 Request for: \$5,000,000 grant, \$25,000,000 loan

**Summary of Project:** This project supports the design and construct a low-carbon renewable fuels refinery near Trenton, ND which uses soybean oil as the feedstock.

### Technical Review Results

Overall Technically Sound (253.5/315)		
Good	1	
Fair	1	
Questionable		

### BND Economic Feasibility Recommendation

Overall Economic Feasibility	
Yes	X
No	

### Technical Committee Scores

	Score (Out of 50)
Charlie Gorecki	40
Josh Teigen	25
Dave Glatt	34
Lynn Helms	41
Justin Kringstad	39
Rachel Retterath	39
Todd Steinwand	44
John Weeda	47

Average: 39

**Recommendation: 8-0 Consider funding**

# TECHNICAL REVIEWERS' RATING SUMMARY

## C-04-B

SAFuels X

Submitted By: AIC Energy Corp.

Date of Application: May 2023

**Request for \$5,000,000 Grant and \$25,000,000 Loan**

**Total Project Costs \$525,000,000**

Rating Category	Weighting Factor	Technical Reviewer		Average Weighted Score
		B1 Rating	B2 Rating	
1. Objectives	3	5	4	13.5
2. Impact	9	4	4	36
3. Methodology	9	5	2	31.5
4. Facilities	3	5	3	12
5. Budget	9	4	4	36
6. Partnerships	9	5	4	40.5
7. Awareness	3	4	4	12
8. Contribution	6	5	2	21
9. Project Management	6	5	3	24
10. Background	6	5	4	27
<b>315</b>		<b>294</b>	<b>213</b>	<b>253.5</b>

**OVERALL TECHNICALLY SOUND**

GOOD (IF > 214)	<input checked="" type="checkbox"/>	<input type="checkbox"/>	
FAIR (200-213)	<input type="checkbox"/>	<input checked="" type="checkbox"/>	
QUESTIONABLE (IF < 200)	<input type="checkbox"/>	<input type="checkbox"/>	

Mandatory Requirements	B1		B2	
	Yes	No	Yes	No
Diversification Delivery:	Yes	No	Yes	No
Project enhances the production of clean sustainable energy, to make the State a world leader in the production of clean sustainable energy, and/or to diversify and grow the State's economy.	✓		✓	
Commercialization or Development/Expansion:	Yes	No	Yes	No
Concept will lead to the <b>large-scale development and commercialization</b> of projects, processes, activities, and technologies that reduce environmental impacts and/or increase sustainability of energy production and delivery.	✓		✓	

In State Requirement:	Yes	No	Yes	No
The funds distributed from the financial assistance are to be applied to support in-state activities and must have other sources of financial support.	✓		✓	

- The objectives or goals of the proposed project with respect to clarity and consistency with Clean Sustainable Clean Energy Authority goals of projects, processes, activities, and technologies that reduce environmental impacts and increase sustainability of energy production and delivery are: 1 – very unclear; 2 – unclear; 3 – clear; 4 – very clear; or 5 – exceptionally clear.**

**Reviewer B1 (Rating 5)**

Manufacturing of biobased jet fuels for military aircraft and biobased diesel and naphtha for transportation fuels from soybean oil fits well within the scope of the Clean Sustainable Clean Energy Authority goals. The applicants estimate that the replacement of conventional jet fuel by bio jet fuel manufactured in the SAFX facility would save 390,000 tons of carbon dioxide release per year.

**Reviewer B2 (Rating 4)**

Overall, the objectives are clearly stated and well-defined – the goal is to produce a drop-in replacement for jet, diesel, and other petroleum-based fuels using a combination of soybean/canola oil as well as natural gas as a feedstock and utilizing the H2Bridge pathway. The methodology has been proven and deployed and utilized in several other projects around the world. The funds from the CSEA would be used for designing and scoping the pipeline that would provide natural gas to the H2Bridge facility.

- The objectives will make a difference in the near term to the state’s economy: 1 – no impact; 2 – small impact; 3 – likely impact; 4 – most likely impact; or 5 – significant impact.**

**Reviewer B1 (Rating 4)**

The applicants are nearing the construction of their biofuel manufacturing facility in northwest North Dakota. The construction of the facility, planned for late 2025, will create 300 construction-related jobs and once in operation, the facility will employ 75 workers directly and provide new commerce to business partners that will create additional jobs. The proposal states that the impact of the facility will be approximately \$515 million per year. If successful, this facility will complement the existing biofuels portfolio existing in ND by creating a new market in bio jet fuel. The project will utilize local sources of utilities and ND-cultivated soybean oil.

**Reviewer B2 (Rating 4)**

Aside from the immediate benefits of the construction project, the project will also utilize several fuels and feedstocks that are locally produced (petro-based as well as agricultural). Thus, the project can be seen as having first-order impacts in terms of jobs/construction benefits but also second- and third-order benefits from the utilization of local resources that will provide economic activity to nearby business and farmers. This helps keep the ‘money in the state’ over the long run as opposed to purchasing non-ND goods.

- 3. The quality and clarity of the methodology in the proposal is: 1 – well below average; 2 – below average; 3 – average; 4 – above average; or 5 – well above average.**

**Reviewer B1 (Rating 5)**

The proposed activities, FEL4 engineering design and design of the natural gas plumbing system will be performed by Richard Design Services (RDS), who have access to the necessary methodologies. RDS is experienced in design and construction of bioenergy facilities.

**Reviewer B2 (Rating 2)**

This is my biggest concern – the technology has been proven and is helpful in reducing emissions. However, the federal government has offered several large incentives for producing hydrogen through renewable electricity sources via electrolysis. Using H2Bridge, likely a steam methane reforming (SMR) variant, to produce hydrogen is both (a) financially inferior to electrolysis (or SMR with carbon capture and storage [CCS]) given the massive federal incentives and (b) worse in terms of direct and lifecycle emissions as the alternative technologies. I feel the project has a reasonably-clean output without these two but layering on a cleaner hydrogen production technology would really put it at the forefront of clean fuel production technologies. Referencing the same GREET model used in their environmental analysis, the SMR with CCS or electrolysis platforms could reduce emissions per GGE by either 84% or 93%, respectively, as compared to the 41% presented here. Thus, the same technology could be used but either adding on carbon capture or utilizing electrolysis with renewable electricity input could both bring financial and environmental benefits.

This is also contentious as the money from CSEA would be used primarily to provide the scoping and backing for a natural gas pipeline which seems rather contradictory to the clean energy objectives.

- 4. The facilities and equipment available and to be purchased for the proposed pilot or commercialization strategy is: 1 – very inadequate; 2 – inadequate; 3 – adequate; 4 – notably good; or 5 – exceptionally good.**

**Reviewer B1 (Rating 5)**

The participants in the proposed design, construction, and operation of the SAFX biofuels facility are internationally recognized for their expertise with biofuel facility establishment (e.g., Haldor Topsoe, RDS) possess the necessary facilities and equipment needed to complete the proposed designs. No facilities or equipment will be purchased using the proposed funds.

**Reviewer B2 (Rating 3)**

No major concerns – the technology has been demonstrated and the facilities have no extremely-specialized or otherwise unavailable or untested equipment associated with it. The timeline for installation as well is rather realistic and demonstrates a thorough understanding of the challenges and hurdles facing projects at this scale.

- 5. The proposed budget is comprehensive and sufficient relative to the outlined work and the timetable: 1 – not sufficient; 2 – possibly sufficient; 3 – likely sufficient; 4 – most likely sufficient; or 5 – certainly sufficient.**



**Reviewer B1 (Rating 4)**

The proposed engineering designs, amounting to \$48.5 million, accounts for 9.2% of the overall cost of constructing the facilities (\$525 million). The proposed budget for the establishment of the SAFX facility as given in Appendix D is well detailed.

**Reviewer B2 (Rating 4)**

Budget is detailed clearly and concisely – no major concerns and there is sufficient cost share among partners and sponsors. The biggest issue is the scope and allocation of the CSEA funds.

- 6. The appropriate strategic partnerships are in place for short and long term plans to be successful: 1 – very limited; 2 – limited; 3 – adequate; 4 – better than average; or 5 – exceptional.**

**Reviewer B1 (Rating 5)**

The applicant, AIC, has assembled an excellent team that is experienced in the establishment of biofuels-related facilities, including Haldor Topsoe, provider of the technological approach, RDS, contributing the engineering design and management of the construction, Bartlett Grain, provider of the refined, bleached, and deodorized soybean oil, among many others.

**Reviewer B2 (Rating 4)**

The partnerships are not only strong but most, within reason (e.g. electricity supply), are from within the boundaries of North Dakota or within the Midwest region. None identified are foreign and the larger entities are within a few 100 miles of the identified construction site.

- 7. The likelihood that the project approach (time & budget) will achieve its technical and market goals is: 1 – not achievable; 2 – possibly achievable; 3 – likely achievable; 4 – most likely achievable; or 5 – certainly achievable.**

**Reviewer B1 (Rating 4)**

The applicants have prepared a comprehensive plan for the design, construction, and start-up of the SAFX biofuel facility.

**Reviewer B2 (Rating 4)**

The timing, methodology, and scope are all within reason and expectations. The proposal also conveys an understanding of the challenges and solutions to conquering the foreseen hurdles such as permitting etc.

- 8. The scientific and/or technical contribution of the proposed work to specifically address Clean Sustainable Energy Authority goals of impacting technology used in North Dakota's energy industries will likely be: 1 – extremely small; 2 – small; 3 – significant; 4 – very significant; or 5 – extremely significant.**

**Reviewer B1 (Rating 5)**

The technological approach developed by Haldor Topsoe, “Hydroflex” and “H2Bridge”, is state-of-the-art, involving novel catalysts and hydrogen for saturating the double bonds of soybean oil and then deoxygenation, with hydrogen produced from short-chain hydrocarbon co-products

resulting from the reaction. The approach is flexible, allowing the facility to adjust the relative production of jet fuel and diesel to meet customer and market demands. The naphtha co-product can be used to prepare bioethanol or other biobased chemicals. As mentioned in my response to Q2, the successful production of bio jet fuel can be transformative in reducing greenhouse gas emission from conventional fossil fuel-based jet fuel.

**Reviewer B2 (Rating 2)**

The project scope and purpose is addressing a strong need within a hard-to-decarbonize sector such as aviation fuels. The provision of such fuels at reduced- or zero-carbon intensity would be a huge step up for renewable fuel technologies and fill a niche that is otherwise unaddressed. However, incentives are in place for technologies that would offer less environmental impact.

- 9. The project management plan, including budgeting projections, partner connections and well-defined milestone chart is: 1 – very inadequate; 2 – inadequate; 3 – adequate; 4 – notably good; or 5 – exceptionally good.**

**Reviewer B1 (Rating 5)**

The applicants have prepared a detailed Gantt chart for completing deliverables, to achieve ground-breaking for the facility in early 2024 and start-up in late 2025. AIC and partners appear to have good working relationships within the team. Section 5.2 of the proposal outlines several strategies for mitigation of risk, including the use of “third-party reviews to identify information gaps in the project.”

**Reviewer B2 (Rating 3)**

No major comments here – The proposal is lacking in its *future* milestones specification (ie it ends in April 2023) but there is sufficient information in the text to understand their intended plan.

- 10. The background and experience of the project principals with regards to technical qualifications and competence is: 1 – very limited; 2 – limited; 3 – adequate; 4 – better than average; or 5 – exceptional.**

**Reviewer B1 (Rating 5)**

The project leaders from AIC, Mr. Melk, Mr. Keller, and Mr. Stack, have the necessary expertise to complete the design, construction, and start-up of the SAFX facility.

**Reviewer B2 (Rating 4)**

Authors and applicants have sufficient experience and credentials to achieve the proposed work. The authors and researchers mentioned in the proposal are more than capable to perform their designated tasks.

---

**Section C. Overall Comments and Recommendations:**

**Please comment in a general way about the merits and flaws of the proposed project and make a recommendation whether or not the project is technically sound.**

**Reviewer B1**

I found this proposal to be strong and compelling. AIC and its partners have made very good progress for laying the foundation to ultimately construct a bio jet fuel facility in Trenton, ND by early 2024 from soybean and perhaps canola oils that uses state-of-the-art catalytic technologies involving hydrogenation and deoxygenation. This proposal, requesting a \$5 million grant and a \$25 million loan, is to prepare an FEL4 engineering design and the design of natural gas lines (\$48.5 million total cost; CSEA funds would account for 61.8% of the needed funds). The applicants have made good strides in arranging for the necessary feedstocks, particularly soybean oil, natural gas, and utilities and have obtained the necessary permits. Bio jet fuel, even blended at a ~25% level (as proposed by AIC), would have a significant impact on the reduction of atmospheric carbon dioxide by the aviation industry. The value proposition by AIC is not solely reliant on making a superior bio jet fuel compared to its competitors, but also focuses upon its status as a minority-owned business, which will facilitate its winning of contracts with the US Department of Defense for military aviation fuels and possibly air freight carriers such as FedEx and commercial airlines such as Southwest. In summary, the proposed SAFX facility will bring state-of-the-art technology to North Dakota to further strengthen its biofuels portfolio and will have a substantial impact on economics, both locally and across the State, including 75 permanent jobs and 300 construction jobs.

**Reviewer B2**

Overall, and speaking frankly, it feels strange to me that a significant amount of CSEA funds would be allocated towards building a natural gas pipeline. Understanding the output of the facility is for a useful and valuable product, there are still various other upstream technologies to produce hydrogen with significantly less environmental impact. Additionally, the potential to capture carbon (and get paid for it through federal incentives) is also of enough merit to mention. That is, without significant alteration to the project production pathway, the environmental impact could be lessened considerably and the project could be overall more profitable.

**Clean Sustainable Energy Authority**

---

**North Dakota Industrial Commission**

## Application

Project Title: SAFuels X

Applicant: AIC Energy Corp

John F. Melk

Date of Application: 5/19/23

Amount of Request

Grant: \$5,000,000

Loan: \$25,000,000

Total Amount of Proposed Project:

\$525,000,000

Duration of Project: 2 years

Point of Contact (POC):

John F Melk- President/CEO

POC Telephone: 702-685-1118

POC Email: [directory@aicenergycorp.com](mailto:directory@aicenergycorp.com)

2830 S. Jones Blvd., Ste. 2

Las Vegas, NV 89146

# Contents

- Confidentially Statement .....1
- 1 ABSTRACT ..... 2
  - 1.1 Objective ..... 2
  - 1.2 Expected Results ..... 2
  - 1.3 Duration ..... 2
  - 1.4 Total Project Cost..... 2
  - 1.5 Participants..... 2
- 2 Project Description ..... 3
  - 2.1 Objectives..... 3
  - 2.2 Methodology..... 3
  - 2.3 Anticipated Results..... 7
  - 2.4 Facilities..... 8
  - 2.5 Resources ..... 9
  - 2.6 Techniques to be Used, Their Availability and Capability.....10
  - 2.7 Environmental Impacts while Project is Underway.....10
- 3 Standards of Success ..... 10
  - 3.1 Emissions Reduction.....10
  - 3.2 Increased Energy Sustainability/Stability ..... 10
  - 3.3 Value to North Dakota ..... 10
  - 3.4 Commercialization of the Project’s Results ..... 11
  - 3.5 Job Preservation & Generation ..... 11
- 4 Background/Qualifications ..... 12
  - 4.1 Major Milestones Achieved..... 12
  - 4.2 Experience and Qualifications ..... 12
- 5 MANAGEMENT ..... 14
  - 5.1 Corporate and Project Management ..... 14
  - 5.2 Project Risk Management ..... 15
- 6 Timeline ..... 16
  - 6.1 Milestones Reached to Date ..... 16
  - 6.2 Future Schedule ..... 16
- 7 Budget ..... 17
- 8 State Programs and Incentives ..... 17

# Clean Sustainable Energy Authority

## Request for Confidentiality

**Applicant:** AIC ENERGY CORP dba SAFuels X

**Application Title:** NDIC CLEAN SUSTAINABLE ENERGY GRANT/LOAN

1. *A general description of the nature of the information sought to be protected.*

All AIC Energy Corp dba SAFuels X financial including but limited to proposals, bids, and cost estimates provided by third party vendors to be held "Confidential". The following appendices, **Appendix B: Historical Financials, Appendix C: Business Plan, Appendix D: Project Budget, and Appendix F: Loan Application**, are requested to remain business confidential.

2. *An explanation of why the information derives independent economic value, actual or potential, from not being generally known to other persons.*

The information being requested confidential contain business specific figures, such as financials. This information is not known to the general public. If the information in the requested confidential sections were made known to the general public, it is possible someone could reverse engineer and duplicate AIC's competitive advantage.

3. *An explanation of why the information is not readily ascertainable by proper means by other persons.*

Access to AIC's business plan and financials are available only to the AIC Board of Directors and financial team. Potential investors and other similar parties have all signed a non-disclosure agreement to access the information.

4. *A general description of any person or entity that may obtain economic value from disclosure that may derive from the information, and how the person or entity may obtain this value.*

If the information was made public, an individual could obtain critical relationship information, market forecasts, technological intellectual property, etc.

5. *A description of the efforts used to maintain the secrecy of the information.*

AIC Energy Corp has executed non-disclosure agreements in place with all vendors and clients.

  
\_\_\_\_\_  
Signature

\_\_\_\_\_  
President/CEO

\_\_\_\_\_  
Title

\_\_\_\_\_  
May 19, 2023

\_\_\_\_\_  
Date

# 1 ABSTRACT

## 1.1 Objective

AIC Energy Corp's (AIC) SAFuels X facility is seeking a grant of \$5 million and a loan commitment of \$25 million from the Clean Sustainable Energy Authority.

AIC's objective is to obtain financial assistance from the North Dakota Industrial Commission Clean Sustainable Energy Authority (CSEA) to design, construct and operate a renewable fuels facility and blending plant (SAFX facility). This facility will bring stable, well-paying jobs to the north-west region of North Dakota and create high-value added agriculture products.

## 1.2 Expected Results

The SAFX facility will create 300 (peak) industrial & commercial construction jobs, more than 75 permanent jobs, plus numerous additional jobs for secondary industries such as: trucking, industrial service vendors, rail workers and suppliers. Additionally, the local economy will expand to support the housing and subsistence of these vendors, workers, and families.

- The feedstock initially will be RBD soybean oil. Bartlett Grain has been selected as the broker for the facilities feedstock. Bartlett Grain has also guaranteed product quality based on National Oil Producer Association standards.
- The impact on agriculture production will be significant and provide an improved long term, stable consumer & base price for feedstock producers.
- The facility will produce approximately 70 million gallons of renewable jet fuel annually, and 20 million gallons of renewable diesel. Haldor Topsoe has provided yield guarantees on jet fuel production.
- The renewable jet fuel will then be blended with mineral (petroleum based) jet fuel to create blended sustainable aviation fuel (SAF).
- The project will utilize large amounts of locally sourced energy, including electricity and natural gas, requiring the expansion of these utilities and using an under-utilized natural gas resource.

## 1.3 Duration

The detailed engineering (FEL 4) of the project is expected to start in early June 2023 and expected to continue for 15 months. A construction start in Q1 of 2024 is expected with underground utilities and foundations and scheduled to reach steady state around Q4 of 2025. This facility is expected to operate well beyond 30 years.

## 1.4 Total Project Cost

\$525,000,000 is the current project development cost including working capital. Please see the business plan full financial projections.

## 1.5 Participants

AIC Energy Corp is the sole owner of the SAFuels X refinery located in Trenton, ND. Feedstock agreements are in place with Bartlett Grain for RBD soybean oil. A confidential offtake agreement has been obtained for all products produced at the facility. Natural gas transmission is in negotiation with WBI Energy and supply from Rainbow Energy Marketing Corp. Electricity and raw water supply will be supplied from Lower Yellowstone REC and M&M Water respectively. Haldor Topsoe is the technology supplier. Richard Design Services is the Engineer, Procurement, and Construction Management partner for the project.

## 2 Project Description

### 2.1 Objectives

AIC Energy Corp's (AIC) objective is to design, permit, build, and operate the SAFuels X refinery (facility) in Trenton, ND. The SAFuels X (SAFX) facility will produce renewable jet fuel to be blended into sustainable aviation fuel (SAF), renewable diesel, and renewable naphtha as sellable products. SAF and renewable diesel are 'drop-in' replacements for existing transportation fuels. Renewable naphtha is a gasoline or chemical feedstock. The primary feedstock for the SAFX facility is expected to be soybean oil, although canola oil and other regionally grown oilseed oils are capable of being used as feedstock. The feedstock oil intake capacity of the facility will be 90 to 100 million gallons per year (6500 barrels per day), resulting in nearly a 1:1 volume yield. The resulting renewable fuels will reduce net carbon dioxide emissions by 41%. The SAFX facility will bring stable, well-paying jobs to the north-west region of North Dakota and create high value-added agriculture products.

### 2.2 Methodology

AIC is the developer for this project and has selected Haldor Topsoe as the technology provider. The engineering, procurement, and construction management consultant will be Richard Design Services (RDS). These experienced contractors will provide the bulk of the technology and engineering services required for this project. Additional engineering and consulting services were provided by North Dakota firms such as Keitu Engineers & Consultants and Interstate Engineering.

#### 2.2.1 Use of CSEA Funds

AIC is requesting \$5 million in grants and \$25 million in loans from the Clean Sustainable Energy Authority (CSEA). These funds will be used for the remainder of engineering and the natural gas line design. The detail design engineering will be performed by RDS and will cover the engineering for the SAFX facility on site. The natural gas line design will be done by WBI and will cover the engineering and permitting costs. For a further detailed budget of how these costs relate to the rest of the cost of the project, please see the breakdown in the Budget Section.

*Table 1 – CSEA funding requested for the SAFuels X facility.*

Line Item	CSEA Grant Request	CSEA Loan Request
Detailed Engineering	\$ 5,000,000	\$ 23,000,000
NG Line Design & Permitting	\$ 0	\$ 2,000,000
<b>Total Requested</b>	<b>\$ 5,000,000</b>	<b>\$ 25,000,000</b>

Table 1 above illustrates the costs AIC is requesting CSEA to fund by grant and/or loan. AIC will match the total requested costs by greater than a 50/50 match. The requested costs include detailed design engineering for the facility and full design and permitting for the natural gas line. The remaining costs for the project will be matched by a combination of the applicant's equity and development financing. The requested items are based on contracts and proposals for the status of the project. A more detailed line item of the budget as well as assumptions made in the budget can be found in Appendix D.

The clean energy funding program is a vital component in assisting AIC in meeting its financial goal. These funds will enhance our abilities to advance the project timeline forward by enabling engineering to be completed and allowing AIC to begin the procurement process with detailed equipment specifications. The funds are vital to keep the project on an aggressive schedule.



### 2.2.2 Key AIC Personnel

Mr. John F. Melk is the President and Chief Executive Officer (CEO) for AIC Energy Corp. Mr. Melk is a native of North Dakota and was raised locally in Minot, ND. He is a federally enrolled Native American with the Turtle Mountain Band, Chippewa Indians, Belcourt, ND. Mr. Melk is also a retired member of the Local UA 300 Union for Steamfitters and Pipefitters. He was an erector for Combustion Engineering at the Coal Creek Generating Station in Underwood, North Dakota. Mr. Melk also managed the installation of the isomerization system at the, at the time, Amoco oil refinery located in Mandan, ND. He also has an extensive and wide-ranging career in contracting for the U.S. Government, including working on cryogenic systems, ferrofluid dynamics systems, and fueling systems for missiles.

The lead engineer for the SAFuels X project is Mr. Kristopher Keller, P.E. Kris is responsible for engaging and coordinating multiple engineering groups and disciplines, along with technology providers, for the design, permitting, and construction of the SAFX facility. Kris's prior experience includes reliability and performance engineering with North Dakota power cooperatives, project & district manager at a major oil field service company, and a process development engineer for a multi-national ag processor. He also previously conducted detailed design engineering and construction management for a greenfield LPG fractionation facility in North Dakota. Most recently, he was the Senior Project Engineer with a local engineering & consulting company providing support for this project. He currently holds professional engineering licenses in both North Dakota and Montana.

Mr. Phillip Stack is AIC's senior engineer. Phillip is responsible for project financial forecasting, early engineering of potential sites, and assisting the lead engineer to bring a project to completion. His work experience includes evaluation of carbon intensity incentives, forecasting of feedstock and incentive prices, and project economic modeling. He is a graduate of the University of North Dakota where he received a Master of Business Administration (MBA) with a focus in data analytics. Additionally, Phillip has a master's degree in chemical engineering.

### 2.2.3 Project Technology

The SAFX facility will utilize Haldor Topsoe's Hydroflex and H2Bridge technology. Haldor Topsoe is an industry leader in renewable fuels production. The technology is based on traditional petroleum refining techniques but has been modified for renewable fuels production.

Soybean oil is an unsaturated fat known as a triglyceride, meaning that it has 3 long chain fatty acids connected together by a glycerol backbone. The Hydroflex unit uses hydrogen generated in the H2Bridge together with proprietary catalyst to hydrogenate double carbon bonds and de-oxygenate the fatty acids and glycerol. The hydrogenated, de-oxygenated glycerol converts into propane, which is separated and becomes a feedstock in the H2Bridge. The de-oxygenated portion of the fatty acid becomes water and is separated out of the process. The hydrogenated, de-oxygenated fatty acids changes into paraffins. Paraffins are long chain hydrocarbons that must be isomerized to improve cold weather and combustion performance. The isomerized hydrocarbons are fractionated into the main products – renewable naphtha, renewable jet fuel, and renewable diesel.

In 100% diesel mode, only renewable diesel and renewable naphtha are produced. In 100% jet mode, the renewable diesel which would be produced is recycled and hydrocracked into additional jet fuel and light hydrocarbons. The light hydrocarbons are used as a feedstock for the H2Bridge. The renewable naphtha can be separated into light and heavy naphtha or remain as full-range naphtha. Heavy naphtha can be used as a renewable gasoline blend stock or renewable chemical feedstock. The light naphtha is sent to the H2Bridge as feedstock in diesel mode but sold to a commercial user in jet mode. Use of the renewable light naphtha and

light hydrocarbons in the H2Bridge will reduce the carbon intensity of the end products by displacing natural gas as a feedstock.

Across the world, at least 16 refineries are utilizing similar technology from Haldor Topsoe for renewable diesel production. The SAFX facility will be the first greenfield site producing renewable jet fuel. Being a greenfield site, the facility will be integrated for minimal energy use. This integration allows for waste to be reduced, energy usage to be optimized, and feedstock to product be maximized. The technology also will enable AIC to take advantage of low-carbon techniques developed in prior facilities by Haldor Topsoe.

Currently, the project is at the end of the FEL-3 engineering phase, beginning of detail design. AIC is requesting funding to facilitate the detailed design of the SAFX facility. During the detail design, the facility construction will commence with civil work and procurement of long lead time components. By the end of detailed design, the complete facility can be constructed. It is the detailed design where the Haldor Topsoe technology is fully integrated into the SAFuels X project.

#### 2.2.4 Engineering, Procurement, & Construction Management Contractor

Richard Design Services, Inc. (RDS) is a full-service engineering, procurement, and construction management company. RDS has extensive experience in both the petrochemical and petroleum refining industries. The company and personnel are licensed and in good standing with multiple engineering and industrial certifications. Their services include conceptual and front-end consulting, total installed cost estimates, conceptual, preliminary and/or detailed design, procurement, and construction management. RDS has experience with Haldor Topsoe technology and has completed several renewable fuels projects in Louisiana and Montana. RDS has also performed work on existing fuel processing equipment at a large gas plant in North Dakota. RDS also has experience in modularizing refining operations for aggressive construction schedules.

AIC has engaged RDS to perform the engineering, procurement, and construction management for the SAFuels X project. The project manager for RDS is Mr. Leroy Royer. Leroy has 38+ years of experience in refining and capital improvement projects. He has worked in operations, engineering, and project management for large refiners and specialty chemical manufacturers.

#### 2.2.5 Other Major Project Contributors

AIC has used a variety of specialized contracted companies in addition to Haldor Topsoe and RDS. Table 2 lists the companies used in chronological order.

*Table 2 – List of Specialized Companies used by AIC*

<b>Company</b>	<b>Service</b>
Davis Consulting	General Business Consulting, Grants Advisor
Kirby Engineering	Survey Services
JLG Architects (ND Branch)	Architecture Services
Pinnacle Engineering	Environmental Site Assessment
Beaver Creek	Archaeological Services
Savage Service Corp.	Transloading Facility
Keitu Engineers & Consultants	Feasibility Study, Permitting, Stormwater Project Management
Diamond Resources	Landman Services
M&M Water	Raw Water Supply
Praxis Strategy Group	Business Impact Study
Wenck Associates/Stantec	Environmental Site Assessment
Interstate Engineering	Site Survey, Traffic Study, Stormwater Design
American Engineering and Testing	Geotechnical Report

Table 2 Cont. – List of Specialized Companies used by AIC

Company	Service
Alfa Laval	Wastewater Treatment Technology and Design
Muse, Stancil & Co.	Feedstock Study
Bartlett Grain	Feedstock Sourcing
Nova Energy	Onsite Safety
Eide Bailly	Financial Auditing
Leidos	Third-Party Validation
MRR Inc.	Stormwater Construction
WBI Energy	Natural Gas Transmission
Lower Yellowstone REC	Electricity Supply

### 2.2.6 Permitting Status

All major permits required for construction of the SAFX facility have been obtained. Table 3 shows each of the major permits and when they were received.

Table 3 – Major Permits Required for SAFX Facility Construction

Permit	Date Received
ND State Historic Preservation Office Concurrence Letter	January 28, 2021
ND State Industrial Stormwater Permit	March 18, 2021
Williams County Conditional Use Permit	June 1, 2021
Williams County Zone Change Application	June 1, 2021
Raw Water Intake Permit	July 15, 2021
NEPA Finding of No Significant Impact (FONSI) Letter	October 7, 2021
Air Permit / Permit-to-Construct	February 1, 2023
NPDES Wastewater Discharge Permit	March 23, 2023

### 2.2.7 Major Milestones

The project began in 2020 and is currently at the end of the FEL-3, start of detail design milestone. Table 4 shows the major milestones achieved to date.

Table 4 – Major Milestones Achieved to Date

Milestone	Date Achieved
Project Start	July 2020
Purchase of Property Complete	October 2020
FEL-1 Engineering Complete	December 2020
Technology Providers Selected	April 2021
Conditional Use Permit Issued	June 2021
FONSI Letter Received	October 2021
FEL-2 Engineering Complete	December 2021
FEL-3 Engineering Complete	October 2022
Site Grading Begins – Construction of Stormwater Pond	November 2022
Air Permit / Permit-to-Construct Received	January 2023
Wastewater Discharge Permit Received	March 2023
EPC Contractor Selected	April 2023

## 2.3 Anticipated Results

### 2.3.1 Products

The primary product of the facility is Sustainable Aviation Fuel (SAF). The facility will produce more than 70 million gallons per year of renewable jet fuel. The produced renewable jet fuel will be blended with up to 210 million gallons of mineral jet fuel resulting in 280 million gallons of SAF meeting industry (ASTM) specifications. The maximum blend ratio between renewable to mineral jet fuel is a 1:1 ratio with typical contracts being a 1:3 ratio. The products will be certified at the facility and leave via pipeline to be directly loaded onto outgoing rail cars. For SAF, this results in up to 25 rail cars per day depending on the blending ratio of SAF.

Additionally, the facility can produce up to 85 million gallons of renewable diesel. The facility can be operated in 100% renewable jet or 100% renewable diesel mode or any percentage in-between, with renewable naphtha as the co-product. At 100% renewable diesel production, on average, 8 rail cars per day will be shipped. 2 to 4 rail cars of renewable naphtha will be shipped out per day depending on the production split.

The renewable fuels produced are a direct "drop in" replacement for fuels produced from petroleum. These fuels will reduce the new carbon dioxide put into the atmosphere 41% over mineral based fuels according to California Air Resource Board's GREET 3.0 model.

### 2.3.2 Feedstock & Blend Stock

The primary feedstock for the facility is expected to be soybean oil, although canola oil and other regionally available agricultural products capable of being used as feedstock. The feedstock oil intake capacity of the facility will be 90 to 100 million gallons per year (6,500 barrels per day), resulting in almost a 1:1 volume yield. The feedstock will arrive by rail and be delivered to the SAFX facility via pipeline. This volume constitutes 10 rail cars per day of feedstock consumption. AIC conducted a feedstock study, conducted by Muse Stancil, which determined an ample amount of feedstock availability (soybean oil) in region available by rail. From the field, this constitutes 2.2 million acres of soybeans at the average ND yield of 35 bushels per acre.

The mineral blend stock will arrive by rail and be delivered to the SAFX facility via pipeline. At a 1:3 renewable to mineral jet fuel ration, this requires 19 rail cars per day of mineral jet fuel delivery. Blending for renewable diesel or renewable naphtha is not required. Additional feedstocks include pipeline quality natural gas and water.

### 2.3.3 Environmental Impact

Renewable fuel production results in 41% fewer carbon dioxide emissions compared to mineral based fuels. The AIC facility will avoid net CO<sub>2</sub> emissions by over 390,000 tons per year based on jet fuel for the facility's production. The use of home-grown feedstocks and blend stocks provides a layer of energy price security to the region and country by reducing imports of petroleum from foreign sources.

During construction, AIC will use best construction practices to control site-runoff, and use dust, light, and noise mitigation strategies.

### 2.3.4 Construction Economic Impact

For the direct economic impact, the SAFX facility will create 300 (peak) industrial & commercial construction jobs, more than 75 permanent jobs, plus numerous additional jobs for secondary industries such as: trucking, industrial service vendors, rail workers and suppliers. Additionally, the local economy will expand to support the housing and income of these vendors, workers, and families. Contractor expenditures are expected to exceed \$200 during construction.

Indirect economic value for North Dakota has several layers. Current SAF production combines North Dakota's largest industries, energy, and agriculture. The use of regionally sourced soybean and/or canola oil combined with regionally refined jet fuel with petroleum sourced primarily from the Williston Basin strengthens ND's leadership in both industries. SAF provides an outlet for mineral jet products as part of a more sustainable fuel. The facility will be a large local customer for the agriculture feedstocks providing a stable price point. The estimated dollar amounts can be found in Appendix D.

### 2.3.5 Long Term Economic Impact

The long-term economic impact of the facility will be to have a new commercial and innovative processes and equipment that will refine renewable feedstocks into renewable jet fuel and renewable diesel. SAFuels X economic impact analysis shows a significant impact on the 4-county regional economy. For every job created at the SAFuels X refinery, 4.85 additional jobs will be created in the local economy. For every dollar of earnings at SAFuels X refinery, an additional \$2.51 of earnings will be created in the local economy. The facility will create more than 300 (peak) construction jobs, more than 75 permanent jobs, plus additional jobs for truckers, vendors, rail workers and suppliers. The estimated annual payroll of the permanent employees is \$7 million. Full impact to the local, state, and regional economy is estimated to be \$515 million annually while in operation. This figure does not include mineral jet fuel purchases.

### 2.3.6 Project Need

As the world markets move towards demanding low carbon solutions for transportation fuel, it challenges oil-rich areas, such as North Dakota, to adapt to the new markets. The SAFuels X project helps North Dakota address and innovate ways to keep on the forefront of the transportation industry by combining two strong North Dakota industries – agriculture and petroleum. By using agriculture products to produce renewable jet fuel, farmers in North Dakota can see high value for the soybeans and other seed oil crops the state's farmers grow. By combining the produced renewable jet fuel with petroleum-based jet fuel, the oil industry of North Dakota has an innovative way to remarket their jet fuel. Overall, the SAFuels X project seeks to expand North Dakota's energy dominance and add immense value to both the state's communities and industrial sectors.

## 2.4 Facilities

The bio-refinery will be located on an 87+ acre site southwest of Trenton, N.D. The site is adjacent to Savage Services Trenton rail port and has access to sufficient water, power, and natural gas service to provide for a production facility of this size.

- The site is zoned as "heavy industrial," is adjacent to Savage Services Trenton rail port, and has access to sufficient water, power, and natural gas service to provide for a production facility of this size.
- The site is suitable for construction due to the proximity of nearby rail access, electrical and natural gas utilities, and nearby raw water source.
- A key strategic partner is Savage Industries has an existing rail terminal system on the BNSF main line to load products, unload feedstock and blend stock, and equipment if necessary.
- Lower Yellowstone Rural Electric Cooperatives Marley substation is directly adjacent to the project site with the capacity add additional bays to service the project.
- WBI Energy Transmission has pipeline capacity nearby at their Charbonneau Compressor Station. An approximately 8-mile lateral line supplying natural gas to the site will be constructed for the facility.
- Water line running approximately 5 miles to the AIC site will be installed from the Missouri River where a withdrawal permitted for industrial use is held by M&M Water.

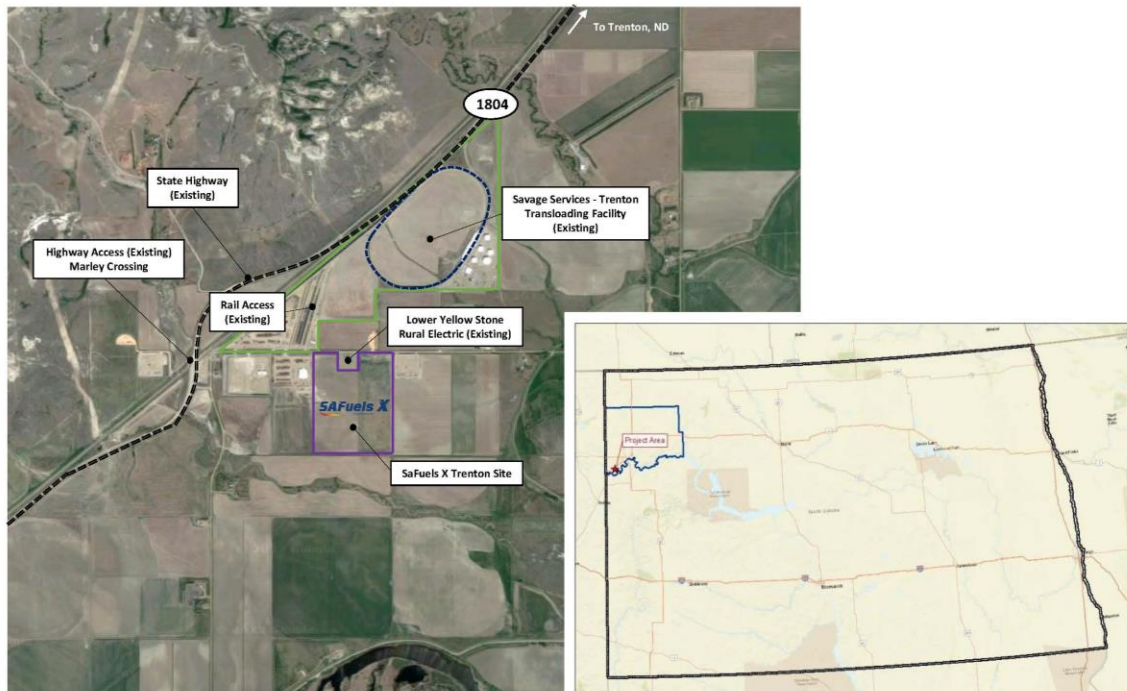

Figure 1 – Location of SAFuels X

## 2.5 Resources

### 2.5.1 Feedstock

The SAFX facility will require 6,500 barrels per day of refined, bleached, and deodorized soybean oil feedstock. This feedstock will be sourced regionally with preference being to utilize closer sources as much as possible. AIC has reached out to feedstock sources in the region and has locked down enough soybean oil feedstock for the SAFX facility. Canola oil can also be used as a feedstock if necessary. The feedstock will arrive via rail at the Savage Services Trenton rail port. A minimum of seven days of feedstock supply will be available on site to reduce supply disruptions. Facility soybean oil consumption is the equivalent of 2.2 million acres.

### 2.5.2 Rail Transport

Savage intends to provide logistical support to AIC by installing rail loading and unloading stations for the required number of rail cars. Additionally, Savage will facilitate rail movements with BNSF for rail car pick-up and delivery of manifest trains and coordinate with AIC for transfer and shipment.

### 2.5.3 Utilities

Natural gas transmission capacity will be provided by WBI Energy through a lateral line to be installed from the Charbonneau Station, approximately 8 miles from the facility, natural gas consumption will be on the order of 60 MMBtu per hour. The line will be able to supply over 400 MMBtu/hr of natural gas for start-up. Water for the facility will be pumped from the Missouri river, approximately 5 miles to the south-west of the site. An existing industrial permit is held by M&M Water. Expected water usage is approximately 750 gallons per minute with a treated wastewater discharge of 600 gallons per minute. The difference is the use of water as a feedstock in the H2Bridge and cooling evaporation.



## 2.6 Techniques to be Used, Their Availability and Capability

AIC's techniques to be used are the entities mentioned in the business plan in Appendix C. AIC has built a team that is addressing all the needs and risks of the development of this plant. Their capabilities include:

- Demonstrated experience with renewable energy projects
- Full understanding and industry recognition in renewable energy economics, incentives, and demand
- Permitting and advisory services related to environmental, energy and regulatory issues
- Design construction experience in renewable and clean energy refinery projects worldwide
- Innovative and creative technology proven worldwide
- Experienced refinery commissioning, start-up, maintenance, and operations
- Contracting and logistics coordination

## 2.7 Environmental Impacts while Project is Underway

A comprehensive study of the environmental and economic impact was completed. The USDA reviewed the environmental assessments conducted by Keitu Engineers & Consultants and issued a letter of Finding of No Significant Impact (FONSI) in October 2021. The SAFX facility will comply with all permits issued by the North Dakota Department of Environmental Quality.

# 3 Standards of Success

## 3.1 Emissions Reduction

Renewable fuel production results in 41% fewer carbon dioxide emissions compared to mineral based fuels. The AIC facility will reduce net CO<sub>2</sub> emissions by over 390,000 tons per year based on jet fuel for the facility's production.

## 3.2 Increased Energy Sustainability/Stability

The use of home-grown feedstocks and blend stocks provides a layer of energy price security to the region and country by reducing imports of petroleum from foreign sources.

## 3.3 Value to North Dakota

### 3.3.1 Communities

The benefit of the SAFX facility will be felt not only locally in the Trenton-Williston area, but throughout the state of North Dakota. Locally, the region will see about 75 full-time direct jobs created. Indirectly, for every full-time job created at the facility, about 4.85 jobs will be created in the community. For every dollar of earnings at the SAFX facility, about \$2.51 will be spent in the local economy. The facility will also draw from technical resources from around the state such as engineering, equipment supply, construction, and other ancillary services. There is additional value when including the annual multi-million-dollar tax benefit the state should see, the SAFX facility will impact four other industries in the state – agriculture, ethanol, natural gas, and petroleum.

### 3.3.2 Industries

#### 3.3.2.1 Agriculture Industry

According to the United States Department of Agriculture (USDA), North Dakota's most valuable crop in 2022 was soybeans. The SAFX facility will utilize soybean oil as its primary feedstock initially. Additionally, canola oil can also be used as a feedstock. The facility will seek to use locally sourced feedstock, when possible, to reduce the carbon intensity of its products. Farmers and other agricultural workers can benefit from the SAFX facility creating a higher demand for their products and thereby adding value.

#### 3.3.2.2 Ethanol Industry

The SAFX facility will produce renewable naphtha as a byproduct of the production of either renewable diesel or renewable jet fuel. This renewable naphtha can be used in the creation of ethanol for denaturant blending. By using a renewable source for the required denaturant in ethanol production the North Dakota ethanol industry can create an even lower carbon intensive ethanol, resulting in a higher value product. Currently, AIC has engaged in conversations with Red Trail Energy's fuel marketer RPMG, in Richardson, ND as a potential offtake for the renewable naphtha byproduct.

#### 3.3.2.3 Natural Gas Industry

The SAFX facility will utilize locally sourced natural gas in its production process via a connection to the WBI gas line in Western North Dakota. Through the addition of the SAFX facility, the natural gas industry will be able to have an increase in local demand. This local demand allows for more take-away capacity in the various near-by gas transmission pipelines – Northern Border and WBI's System.

#### 3.3.2.4 Petroleum Refining Industry

The SAFX produced renewable jet fuel, when combined with petroleum-based, mineral jet fuel creates blended sustainable aviation fuel (SAF). SAF can be blended with up to 50% renewable jet fuel in it according to industry standards (ASTM). However, in recent commercial contract standards, SAF typically contains between 30% and 40% renewable jet fuel. The remaining 60-70% will be mineral jet fuel.

Through the SAFX facility, the North Dakota refining industry will have significant demand for mineral jet fuel. When combined with the renewable jet fuel produced at the SAFX facility, the resulting blended SAF will have a lower carbon intensity than if the mineral jet fuel was sold as-is. The blended SAF created would seek to capitalize on the transportation market's demand for lower carbon alternatives. However, the goal of the SAFuels X project is not to replace the petroleum industry in North Dakota, but rather partner and enhance the petroleum products produced. The partnership between the North Dakota refining industry and SAFuels X will enable North Dakota to remain dominant in the energy industry.

### 3.4 Commercialization of the Project's Results

The SAFX facility will function as a commercial renewable feedstock refinery.

### 3.5 Job Preservation & Generation

The SAFX facility is expected to expand direct job opportunities in the immediate area of Trenton & Williston, ND. Indirect job opportunities will occur over a wider area for technical service providers, vendors, consultants, and suppliers.



## 4 Background/Qualifications

### 4.1 Major Milestones Achieved

The project began in 2020 and is currently at the end of the FEL-3, start of detail design milestone. Table 5 shows a summary of the major milestones achieved to date.

*Table 5 – Major Milestones Reached to Date for the SAFuels X Project*

<b>Milestone</b>	<b>Date Achieved</b>
Project Start	July 2020
Purchase of Property Complete	October 2020
FEL-1 Engineering Complete	December 2020
Technology Providers Selected	April 2021
Conditional Use Permit Issued	June 2021
FONSI Letter Received	October 2021
FEL-2 Engineering Complete	December 2021
FEL-3 Engineering Complete	October 2022
Site Grading Begins – Construction of Stormwater Pond	November 2022
Air Permit / Permit-to-Construct Received	January 2023
Wastewater Discharge Permit Received	March 2023
EPC Contractor Selected	April 2023

### 4.2 Experience and Qualifications

#### 4.2.1 Qualifications of Applicant

AIC's corporate and project management teams are exceptionally experienced and capable in all aspects of the business including designing, permitting, and operating a refinery and sales to DOD and commercial customers. Below is a synopsis of key personnel's biographies. Full biographies of the key personnel and management team is found in Appendix E.

Mr. John F. Melk is the President and Chief Executive Officer (CEO) for AIC Energy Corp. Mr. Melk is a native of North Dakota and was raised locally in Minot, ND. He is a federally enrolled Native American with the Turtle Mountain Band, Chippewa Indians, Belcourt, ND. Mr. Melk is also a retired member of the Local UA 300 Union for Steamfitters and Pipefitters. He was an erector for Combustion Engineering at the Coal Creek Generating Station in Underwood, North Dakota. Mr. Melk also managed the installation of the isomerization system at the, at the time, Amoco oil refinery located in Mandan, ND. He also has an extensive and wide-ranging career in contracting for the U.S. Government, including working on cryogenic systems, ferrofluid dynamics systems, and fueling systems for missiles.

The lead engineer for the SAFuels X project is Mr. Kristopher Keller, P.E. Kris is responsible for engaging and coordinating multiple engineering groups and disciplines, along with technology providers, for the design, permitting, and construction of the SAFX facility. Kris's prior experience includes reliability and performance engineering with North Dakota power cooperatives, project & district manager at a major oil field service company, and a process development engineer for a multi-national ag processor. He also previously conducted detailed design engineering and construction management for a greenfield LPG fractionation facility in North Dakota. Most recently, he was a Senior Project Engineer with a local engineering & consulting company providing support for this project. He currently holds professional engineering licenses in both North Dakota and Montana.

Mr. Phillip Stack is AIC's senior engineer. Phillip is responsible for project financial forecasting, early engineering of potential sites, and assisting the lead engineer to bring a project to completion. His work experience includes evaluation of carbon intensity incentives, forecasting of feedstock and incentive prices, and project economic modeling. He is a graduate of the University of North Dakota where he received a Master of Business Administration (MBA) with a focus in data analytics. Additionally, Phillip has a master's degree in chemical engineering.

#### 4.2.2 Qualifications of Other Participants on Project

##### 4.2.2.1 Haldor Topsoe

The SAFX facility will utilize Haldor Topsoe's Hydroflex and H2Bridge technology. Haldor Topsoe is an industry leader in renewable fuels production. The technology is based on traditional petroleum refining techniques but has been modified for renewable fuels production.

Across the world, at least 16 refineries are utilizing similar technology from Haldor Topsoe for renewable diesel production. The SAFX facility will be the first greenfield site producing renewable jet fuel. Being a greenfield site, the facility will be integrated for minimal energy use. This integration allows for waste to be reduced, energy usage to be optimized, and feedstock to product be maximized. The technology also will enable AIC to take advantage of low-carbon techniques developed in prior facilities by Haldor Topsoe. The facility will also use light hydrocarbons produced in the Hydroflex unit as a feedstock to the H2Bridge hydrogen unit. This novel approach reduces the carbon intensity of the final products.

Currently, the project is at the end of the FEL-3 engineering phase, beginning of detail design. AIC is requesting funding to facilitate the detailed design of the SAFX facility. During the detailed design, the facility construction will commence with civil work and procurement of long lead time components. By the end of detailed design, the complete facility can be constructed. It is the detailed design where the Haldor Topsoe technology is fully integrated into the SAFuels X project.

##### 4.2.2.2 Richard Design Services

Richard Design Services, Inc. (RDS) is a full-service engineering, procurement, and construction management company. RDS has extensive experience in both the petrochemical and petroleum refining industries. The company and personnel are licensed and in good standing with multiple engineering and industrial certifications. Their services include conceptual and front-end consulting, total installed cost estimates, conceptual, preliminary and/or detailed design, procurement, and construction management. RDS has experience with Haldor Topsoe technology and has completed several renewable fuels projects in Louisiana and Montana. RDS has also performed work on existing fuel processing equipment at a large gas plant in North Dakota. RDS also has experience in modularizing refining operations for aggressive construction schedules.

AIC has engaged RDS to perform the engineering, procurement, and construction management for the SAFuels X project. The project manager for RDS is Mr. Leroy Royer. Leroy has 38+ years of experience in refining and capital improvement projects. He has worked in operations, engineering, and project management for large refiners and specialty chemical manufacturers.

##### 4.2.2.3 Specialized Companies

AIC has used a variety of specialized contracted companies in addition to Haldor Topsoe and RDS to address niche gaps. Table 6 lists the companies used in chronological order.

Table 6 – List of Specialized Companies used by AIC

<b>Company</b>	<b>Service</b>
Davis Consulting	General Business Consulting, Grants Advisor
Kirby Engineering	Survey Services
JLG Architects (ND Branch)	Architecture Services
Pinnacle Engineering	Environmental Site Assessment
Beaver Creek	Archaeological Services
Savage Service Corp.	Transloading Facility
Keitu Engineers & Consultants	Feasibility Study, Permitting, Stormwater Project Management
Diamond Resources	Landman Services
M&M Water	Raw Water Supply
Praxis Strategy Group	Business Impact Study
Wenck Associates/Stantec	Environmental Site Assessment
Interstate Engineering	Site Survey, Traffic Study, Stormwater Design
American Engineering and Testing	Geotechnical Report
Alfa Laval	Wastewater Treatment Technology and Design
Muse, Stancil & Co.	Feedstock Study
Bartlett Grain	Feedstock Sourcing
Nova Energy	Onsite Safety
Eide Bailly	Financial Auditing
Leidos	Third-Party Validation
MRR Inc.	Stormwater Construction
WBI Energy	Natural Gas Transmission
Lower Yellowstone REC	Electricity Supply

## 5 MANAGEMENT

### 5.1 Corporate and Project Management

AIC Energy Corp’s corporate and project management teams are exceptionally experienced and capable in all aspects of the business including designing, engineering, permitting, and operating a refinery and sales to DOD and commercial customers. See Business Plan Confidential Separate Document for additional experience bios.

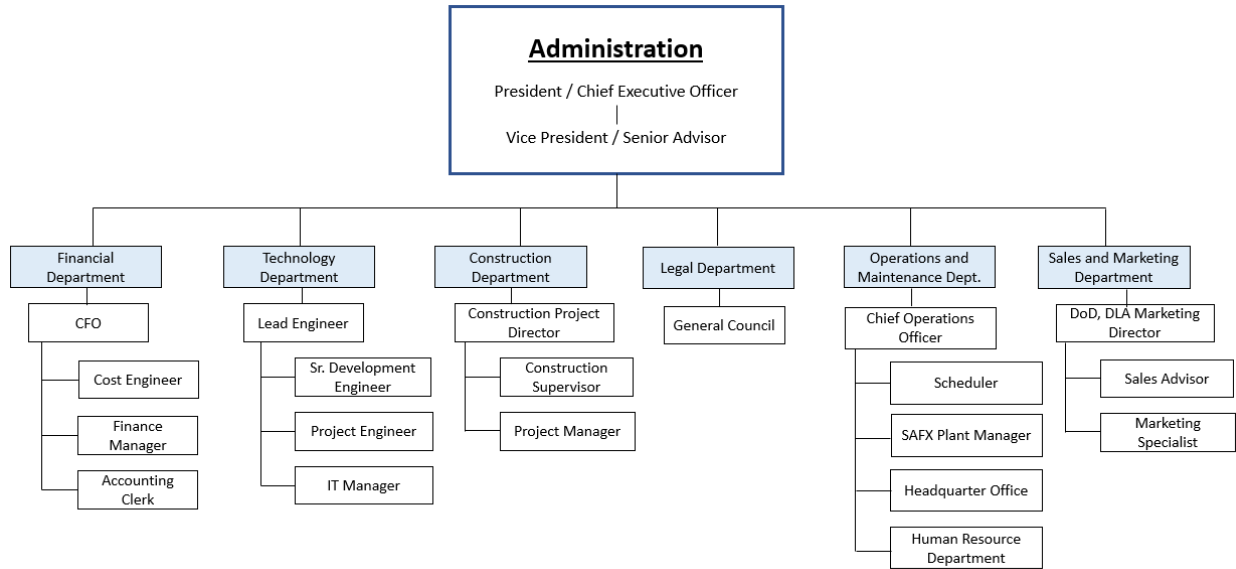

Figure 2 – AIC's Corporate Structure

## 5.2 Project Risk Management

The SAFuels X project risk will be managed and minimized during all portions of the project. Overall risk will be reduced through Management of Change documentation from the detailed design onward and through use of 3<sup>rd</sup> party reviews to identify information gaps in the project. Engineering/design risk will be mitigated through the use of experienced technology providers and EP-CM contracts. Robust Basis of Design documentation has been developed and will be adhered to for detailed design engineering. Additionally, the EP-CM will conduct internal design reviews along with Owner and 3<sup>rd</sup> party design reviews. At the 70% detailed design completion, a Process Safety Analysis will be conducted according to OSHA requirements. Financial risk was mitigated with the use of decision gates at the FEL I, II, and III levels.

Construction risk will be reduced by using an experienced construction manager (CM). The CM, with contractor input or bid, will develop a construction schedule and manpower loading. A detailed construction schedule will be developed with sufficient flexibility to accommodate delivery, weather, and minor delays. Weekly (daily if necessary) job reviews and status meetings will occur to determine if additional resources are required or prioritized elsewhere on the project. Safety risk will be managed through adherence to OSHA standards, such as work teams performing a Job Hazard Analysis prior to beginning a task.

Operational Risk will be mitigated through the use of an experienced commissioning and start-up team. Facility operators will complete formal training and check-out prior to being active in the facility. Continuous improvement training and procedures will be in place to prevent repeat quality or safety incidents from occurring, in addition to robust product quality assurance/quality control procedures. Equipment availability risk will be reduced through a predictive and prescriptive maintenance program where fault indicators are identified prior to catastrophic failure to allow for controlled shutdowns/repairs.

The project risk management will be overseen by AIC's lead engineer, Kris Keller. All contractors for engineering design, fabrication, and construction will report directly to the lead engineer. Kris will also handle all permitting reporting requirements and community relations for AIC until the SAFX facility starts up.

Assisting the lead engineer will be AIC's Senior Engineer, Phillip Stack. Phillip has a background in chemical engineering and will assist mainly during the detail design engineering phase of the project. As part of his

duties, Phillip will review engineering drawings, assist in procurement and scheduling, manage project financials including pro forma financials, and act as a second opinion for the lead engineer.

Both the lead engineer and the senior development engineer report to the Chief Operating Officer (COO) and ultimately the Chief Executive Officer (CEO). AIC’s corporate management structure can be found in Figure 2.

## 6 Timeline

### 6.1 Milestones Reached to Date

Table 7 – Major Milestones Reached to Date for the SAFuels X Project

Milestone	Date Achieved
Project Start	July 2020
Purchase of Property Complete	October 2020
FEL-1 Engineering Complete	December 2020
Technology Providers Selected	April 2021
Conditional Use Permit Issued	June 2021
FONSI Letter Received	October 2021
FEL-2 Engineering Complete	December 2021
FEL-3 Engineering Complete	October 2022
Site Grading Begins – Construction of Stormwater Pond	November 2022
Air Permit / Permit-to-Construct Received	January 2023
Wastewater Discharge Permit Received	March 2023
EPC Contractor Selected	April 2023

### 6.2 Future Schedule

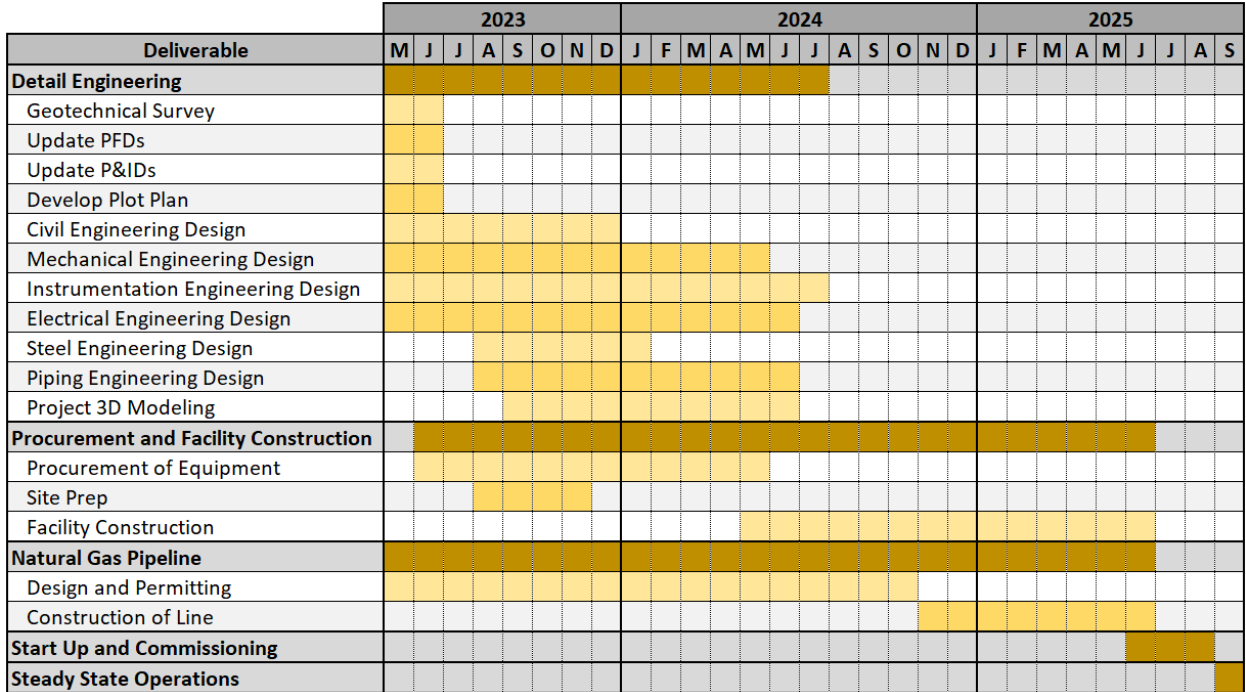

Figure 3 – Tentative Schedule for Design and Construction of the SAFX Facility

## 7 Budget

Table 8 shows the project budget as it relates to CSEA. Please see the business confidential Appendix D for a more detailed breakdown.

*Table 8 – Budget for SAFuels X Project as it Relates to CSEA*

<b>Project Associated Expense</b>	<b>NDIC Grant</b>	<b>NDIC Loan</b>	<b>Applicant's Share (Cash)</b>	<b>Other Project Sponsor's Share</b>	<b>Total</b>
Detailed Engineering	\$ 5,000,000	\$ 23,000,000	\$ 0	\$ 17,000,000	\$ 45,000,000
Natural Gas Line Design	\$ 0	\$ 2,000,000	\$ 0	\$ 1,500,000	\$ 3,500,000
Other Items	\$ 0	\$ 0	\$ 23,500,000	\$ 453,000,000	\$ 476,500,000
<b>Total</b>	<b>\$ 5,000,000</b>	<b>\$ 25,000,000</b>	<b>\$ 23,500,000</b>	<b>\$ 471,500,000</b>	<b>\$ 525,000,000</b>

## 8 State Programs and Incentives

AIC has been awarded funding from the following State of North Dakota's programs and incentives shown in Table 9.

*Table 9 – State programs and incentives AIC has participated in.*

<b>Award Date</b>	<b>Program/Incentive</b>	<b>Award Amount</b>
February 2021	APUC Grant	\$ 212,000
November 2021	APUC Grant	\$ 60,000

Submitted by: SandPro LLC  
 Project Duration: 12 months  
 Total Project Costs: \$1,975,000  
 Request for: \$705,000 grant

**Summary of Project:** This project supports the development of a consolidated solution that brings together various automation products for the oil and gas industry, including remote well control, flow control, well containment, leak detection, and pressure management.

### Technical Review Results

Overall Technically Sound (141/315)		
Good		
Fair		
Questionable	2	

### BND Economic Feasibility Recommendation

Overall Economic Feasibility	
Yes	X
No	

### Technical Committee Scores

	Score (Out of 50)
Charlie Gorecki	25 with conditions
Josh Teigen	28
Dave Glatt	27
Lynn Helms	28
Justin Kringstad	32 with conditions
Rachel Retterath	30
Todd Steinwand	25
John Weeda	29

Average: 28

**Recommendation: 8-0 Consider funding with condition that the applicant obtains an oil and gas industry partner for the project**

# TECHNICAL REVIEWERS' RATING SUMMARY

## C-04-C

Smart Well Hub

Submitted By: SandPro LLC

Date of Application: May 2023

**Request for \$705,000 Grant**

**Total Project Costs \$1,975,000**

Rating Category	Weighting Factor	Technical Reviewer		Average Weighted Score
		C1 Rating	C3 Rating	
1. Objectives	3	3	3	9
2. Impact	9	2	3	22.5
3. Methodology	9	2	2	18
4. Facilities	3	2	3	7.5
5. Budget	9	2	1	13.5
6. Partnerships	9	3	3	27
7. Awareness	3	2	1	4.5
8. Contribution	6	1	2	9
9. Project Management	6	2	2	12
10. Background	6	3	3	18
<b>Total</b>		<b>138</b>	<b>144</b>	<b>141</b>

**OVERALL TECHNICALLY SOUND**

GOOD (IF > 214)	<input type="checkbox"/>	<input type="checkbox"/>	
FAIR (200-213)	<input type="checkbox"/>	<input type="checkbox"/>	
QUESTIONABLE (IF < 200)	<input checked="" type="checkbox"/>	<input checked="" type="checkbox"/>	

Mandatory Requirements	C1		C3	
	Yes	No	Yes	No
Diversification Delivery:	Yes	No	Yes	No
Project enhances the production of clean sustainable energy, to make the State a world leader in the production of clean sustainable energy, and/or to diversify and grow the State's economy.	✓		✓	
Commercialization or Development/Expansion:	Yes	No	Yes	No
Concept will lead to the <b>large-scale development and commercialization</b> of projects, processes, activities, and technologies that reduce environmental impacts and/or increase sustainability of energy production and delivery.	✓		✓	



In State Requirement:	Yes	No	Yes	No
The funds distributed from the financial assistance are to be applied to support in-state activities and must have other sources of financial support.	✓		✓	

- The objectives or goals of the proposed project with respect to clarity and consistency with Clean Sustainable Clean Energy Authority goals of projects, processes, activities, and technologies that reduce environmental impacts and increase sustainability of energy production and delivery are: 1 – very unclear; 2 – unclear; 3 – clear; 4 – very clear; or 5 – exceptionally clear.**

**Reviewer C1 (Rating 3)**

The goals and objectives include improving safety, efficiency, and operability through use of instrumentation, automation, and remote control. Although these goals are consistent with CSEA, it's unclear what technology innovation exists that warrants grant funds.

**Reviewer C3 (Rating 3)**

The overall objectives and strategy for the Smart Well Hub are generally clear and are consistent with Clean Sustainable Energy Authority.

- The objectives will make a difference in the near term to the state's economy: 1 – no impact; 2 – small impact; 3 – likely impact; 4 – most likely impact; or 5 – significant impact.**

**Reviewer C1 (Rating 2)**

Well site automation could make an impact on the state's economy by creating new jobs to install and maintain automation systems and alter exiting well-site operations jobs using the new systems. The net effect on job creation may be small but was not described.

**Reviewer C3 (Rating 3)**

The automation associated with the use of Smart Well Hub has the potential to improve the operational efficiency, safety, and emissions. In addition, this system has the potential to reduce operational costs.

- The quality and clarity of the methodology in the proposal is: 1 – well below average; 2 – below average; 3 – average; 4 – above average; or 5 – well above average.**

**Reviewer C1 (Rating 2)**

The methodology to be used to perform the work was not clearly stated.

**Reviewer C3 (Rating 2)**

The proposal did not include a project description section inclusive of a methodology consisting of task structure and clearly defined deliverables.

- The facilities and equipment available and to be purchased for the proposed pilot or commercialization strategy is: 1 – very inadequate; 2 – inadequate; 3 – adequate; 4 – notably good; or 5 – exceptionally good.**

**Reviewer C1 (Rating 2)**

It is not clear if the scope includes building a prototype or instrumenting several well sites.

**Reviewer C3 (Rating 3)**

SandPro automation division has a shop but no description of the facilities were included. Project partners including Logical Controls, Native Energy, and Black Pearl Technologies appear to provide facilities and support to perform the project.

- 5. The proposed budget is comprehensive and sufficient relative to the outlined work and the timetable: 1 – not sufficient; 2 – possibly sufficient; 3 – likely sufficient; 4 – most likely sufficient; or 5 – certainly sufficient.**

**Reviewer C1 (Rating 2)**

The scope of work is unclear and therefore difficult to determine if the budget is sufficient.

**Reviewer C3 (Rating 1)**

The budget has no task structure and there is no breakdown by typical budget categories that include personnel, fringe benefits, supplies, travel, equipment, and overhead.

- 6. The appropriate strategic partnerships are in place for short and long term plans to be successful: 1 – very limited; 2 – limited; 3 – adequate; 4 – better than average; or 5 – exceptional.**

**Reviewer C1 (Rating 3)**

The proposed project team seems adequate to build and deploy process control and data acquisition systems.

**Reviewer C3 (Rating 3)**

Project partners include Logical Controls, Native Energy, and Black Pearl Technologies. In addition, SandPro indicated that they have MSA's with the major operators in the Bakken. No letters of support or commitment were included in the proposal from project partners or potential users of the technology.

- 7. The likelihood that the project approach (time & budget) will achieve its technical and market goals is: 1 – not achievable; 2 – possibly achievable; 3 – likely achievable; 4 – most likely achievable; or 5 – certainly achievable.**

**Reviewer C1 (Rating 2)**

Market goal is not clearly stated. The proposal does not describe the challenges that preventing more widespread well-site automation nor the activities this project would perform to overcome those challenges.

**Reviewer C3 (Rating 1)**

No detailed project approach was included in the proposal and could not be evaluated in terms achieving it technical and market goals based on time committed to the project and budget.

- 8. The scientific and/or technical contribution of the proposed work to specifically address Clean Sustainable Energy Authority goals of impacting technology used in North Dakota's energy industries will likely be: 1 – extremely small; 2 – small; 3 – significant; 4 – very significant; or 5 – extremely significant.**

**Reviewer C1 (Rating 1)**

Process automation is commercially available technology, but not widely used in well-site operations due to cost, industry preference, and remote location/available communication infrastructure. The proposal does not adequately describe what innovative approaches are being applied that aren't already available in the marketplace.

**Reviewer C3 (Rating 2)**

The proposal provided limited information to allow for an assessment of the scientific and technical contribution of the work.

- 9. The project management plan, including budgeting projections, partner connections and well-defined milestone chart is: 1 – very inadequate; 2 – inadequate; 3 – adequate; 4 – notably good; or 5 – exceptionally good.**

**Reviewer C1 (Rating 2)**

The management plan contains little detail, the budgeting projections may be appropriate but absence of methodology/scope of work makes assessment difficult, and a milestone chart was not provided.

**Reviewer C3 (Rating 2)**

No detailed project management plan that included budget projections and a milestone chart were included in the proposal. SandPro indicated that part of the project goal was to develop a detailed project plan that would include the scope of work, timeline, and budget. This should be included in the proposal.

- 10. The background and experience of the project principals with regards to technical qualifications and competence is: 1 – very limited; 2 – limited; 3 – adequate; 4 – better than average; or 5 – exceptional.**

**Reviewer C1 (Rating 3)**

No comments provided.

**Reviewer C3 (Rating 3)**

Limited background and experience of project principals was provided in the proposal. No resumes of the key people were included. Based on the information provided the project principal appears to adequate background to manage and direct the project.

---

**Section C. Overall Comments and Recommendations:**

**Please comment in a general way about the merits and flaws of the proposed project and make a recommendation whether or not the project is technically sound.**

**Reviewer C1**

Process automation can accomplish the things proposed and greater deployment of these systems in the Bakken could improve the efficiency and environmental sustainability of oil and gas production. However, this proposal does not describe the factors preventing greater automation use in the Bakken and failed to explain how their approach would address those challenges.

**Reviewer C3**

There is a need for automation solutions for the oil and gas industry and there is likely a role that SandPro can play in the development of Smart Well Hub technology. However, the proposal submitted did not include the information required to evaluate the potential of the project to be technically sound.

The following is to function as a transmittal letter.

Andrew Emmel

SANDPRO LLC

8702 282nd st nw Berthold, ND 58718

701-339-9802

aemmel@sandpro.com

5/18/23

CSEA

## APPLICATION CHECKLIST

Use this checklist as a tool to ensure that you have all of the components of the application package. Please note, this checklist is for your use only and does not need to be included in the package.

<input type="checkbox"/>	Application
<input type="checkbox"/>	Transmittal Letter
<input type="checkbox"/>	Tax Liability Statement
<input type="checkbox"/>	Letters of Support (If Applicable)
<input type="checkbox"/>	Confidentiality Request
<input type="checkbox"/>	Business Plan (Appendix)
<input type="checkbox"/>	Historical Financial Statements (3 years) (Appendix)
<input type="checkbox"/>	Budgeted Projections (Appendix)
<input type="checkbox"/>	Loan/Loan Guarantee Application (if Applicable, Appendix)
<input type="checkbox"/>	Other Appendices (If Applicable)

When the package is completed, send an electronic version to [sustainableenergy@nd.gov](mailto:sustainableenergy@nd.gov) and 2 hard copies by mail to:

Clean Sustainable Energy Authority  
North Dakota Industrial Commission  
State Capitol – 14<sup>th</sup> Floor  
600 East Boulevard Ave Dept 405  
Bismarck, ND 58505-0840

For more information on the application process please visit:  
<http://www.nd.gov/ndic/csea-infopage.htm>

Questions can be addressed to Al Anderson (701) 595-9668.

Clean Sustainable Energy Authority  

---

North Dakota Industrial Commission

## Application

Project Title: **Smart Well Hub**

Applicant: **SandPro LLC**

Date of Application: **5/17/23**

Amount of Request  
Grant: **\$705,000**  
Loan:

Total Amount of Proposed Project: **\$1.975M**

Duration of Project: **12 months to commercialization**

Point of Contact (POC): **Andrew Emmel**

POC Telephone: **701-339-9802**

POC Email: **aemmel@sandpro.com**

POC Address:

**8702 282<sup>nd</sup> st NW**

**Berthold, ND 58718**

## TABLE OF CONTENTS

*Please use this table to fill in the correct corresponding page number.*

<b>Abstract</b>	<b>1</b>
<b>Project Description</b>	<b>2</b>
<b>Standards of Success</b>	
<b>Background/Qualifications</b>	
<b>Management</b>	
<b>Timetable</b>	
<b>Budget</b>	
<b>Confidential Information</b>	
<b>Patents/Rights to Technical Data</b>	
<b>State Programs and Incentives</b>	
<b>Loan/Loan Guarantee Application (if applicable)</b>	



## ABSTRACT

### Objective:

With the SandPro team's experience in Oil and Gas surface wellhead systems, we have seen the industry grow both mechanically and technologically. However, the industry has yet to consolidate and utilize these improvements to their best advantages. The objective of the Smart Well Hub (SWH), is to provide consolidated solutions that improves safety for personnel and the environment, optimizes production and addresses labor challenges. The CSEA grant will allow us to finish development for elements of the solution that are partially complete.

### Expected Results:

- 1) Increased safety for personnel and the environment**
  - 2) Optimized Production outcomes**
  - 3) Provide opportunity to address challenging labor shortages.**
- Remote well control: Operators will be able to control wells remotely, from a safe location. This will reduce the need for workers to be on the well site during hazardous operations.
  - Flow control: Operators will be able to remotely or manually control the flow of fluids from the well to optimize production.
  - Well containment: Wells can be manually, remotely or autonomously shut in if the well exceeds safe operating parameters, keeping personnel out of the danger zone, and containing spills to minimize any potential damage or environmental release.
  - Increased efficiency for operators: Operators will have a single, integrated platform for managing wells. This will reduce the time and effort required to operate wells and improve efficiency.
  - Elimination of biohazards: Sensors will be included that can detect spills and pipe erosion. This allows for preventative maintenance, instead of being reactionary when the inevitable spill occurs.
  - Mitigation of explosions: Sensors will be included that can detect pressure buildup. Alerts will then immediately be sent if a certain predetermined pressure is reached. This allows for quick action to be taken to prevent a blowout from occurring.
  - Reduced staffing requirements: Staffing is a current problem for almost every Oil and Gas company. Automation reduces the number of people required to operate a well

site. This will save Oil and Gas operators money on labor costs, as well as allow them to more accurately budget their projects.

**Duration:**

Time to prototype: 6-8 months.

Time to commercialization 10-12 months.

**Total Project Cost:**

The total cost to completion is estimated to be \$1,975,000

**Participants:**

The main “participant” will be SandPro LLC. That being said, we will continue working with our current partners that include:

Logical Controls, Minot, ND

Native Energy, Tioga, ND

Black pearl, Houston, TX

WSI, Hill City, KS

**Objectives:**

1. Increased safety. Both for workers, as well as environmental.
2. Operational efficiencies in the form of proactive maintenance, labor reduction, and vendor consolidation.
3. Production optimization by way of flow control, solids removal & quantification, and real-time data.
4. Streamline supply chain to allow for maximum serviceability.

**Methodology:**

At SandPro, we are fully immersed in many different segments of the Oil and Gas industry. Namely, for this project, production. We have seen the problems we are looking to solve with this project firsthand. We are not working with hypotheticals. We will take this knowledge that has been gained with real-world experience and apply that to the development of these solutions. This will be done in conjunction with our partners listed above.

**Facilities:**

The facilities that will be used to complete the project will be as follows. Primarily, development will be done in the SandPro automation division shop, which is located in Berthold, ND. Secondly work will be done at Logical Controls (our panel shop) located in Minot, ND.

**Resources:**

Drew Anderson (Director of Automation and Development) will work with a team of engineers and programmers, namely Logical Controls and Black Pearl.

**Techniques to Be Used, Their Availability and Capability:**

All the solution designs will be a continuation of what we have already done and found to be successful. Identifying the current problem, creating a working hypothesis for a solution, working with our team of industry experts to get their insight, then proceeding to work in conjunction with our engineering and programming partners to see the solution come to fruition.

#### **Environmental and Economic Impacts while Project is Underway:**

The SWH will have many benefits that contribute to the stated values of the CSEA. Two that we feel strongly about are spill protection, and methane gas detection. According to the Environmental Protection Agency (EPA), an average of 18 Oil and Gas spills occur per day in the United States. These spills can range in size from a few gallons to millions of gallons. Furthermore, most of these spills occur because of human error, which we will be mitigating through our solutions. Methane emissions are a known source of contention. Reducing methane emissions is key for the longevity of Oil and Gas production, both environmentally and politically.

#### **Ultimate Technological and Economic Impacts:**

The Smart Well Hub is a new technology that has the potential to revolutionize the Oil and Gas industry. It can help to improve safety, reduce costs, and protect the environment.

One of the most significant benefits of the SWH is that it can monitor the status of wellsites and help to reduce the number of people required for safe and efficient operations. This is because it can automate, or allow for remote control, of many tasks that are currently performed on site by humans. For example, the SWH can monitor the well site for fluid and gas leaks and other potential hazards and send alerts to operators if a problem is detected. This means that fewer people are needed on a daily basis to be physically present on the well site, which can help to improve safety and reduce costs.

The SWH can also help to address the current problem of finding enough skilled workers to hire in the Oil and Gas industry. The Oil and Gas industry is facing a shortage of skilled workers, and this is making it difficult to find qualified people to fill open positions. The SWH can help to address this problem by reducing the number of people required for well site operations. This can free up workers to be deployed to other areas where they are needed, and it can also help to reduce costs.

In addition to the benefits mentioned above, the SWH can also help to improve spill prevention and methane gas detection, both of which are giant concerns in the industry.

Overall, the Smart Well Hub is a promising new technology that has the potential to make a significant positive impact on the Oil and Gas industry. It will improve safety, reduce costs, protect the environment, and address the current hiring problem facing almost every Oil and Gas company today.

### **Why the Project is Needed:**

The Oil and Gas industry is one of the most important industries in the world, but it is also one of the most dangerous. The industry still uses many antiquated technologies, which can lead to accidents and injuries. Automation can help to make well sites safer for humans and more friendly for the environment.

### **STANDARDS OF SUCCESS**

*The standards by which the success of the project is to be measured. This may include:*

- **Emissions reduction & reduced environmental impacts** – *By way of methane gas detection, and spill prevention via tubing erosion monitors.*
- **Increased energy sustainability.** *This will be accomplished through complying with current ESG initiatives, ensuring domestic production will be allowed in the years to come.*
- **Value to North Dakota.** *North Dakota is a bastion of domestic energy. We intend to do our part to keep it that way. Again, by ensuring compliance with ESG initiatives and green movements, we can keep Oil and Gas as a main economic driver for the foreseeable future.*
- **The potential commercialization of the project's results.** *Our Smart Well Hub will greatly impact the bottom line for many of the giant operators that are currently working in the state. By reducing their payroll costs, as well as helping them budget for projects as our system will be turn-key and they will know exact costs per well.*
- **How the project will enhance the research, development and technologies that reduce environmental impacts and increase sustainability of energy production and delivery of North Dakota's energy resources.** *This is what the Smart Well Hub is all about. New technology streamlining well site processes. Allowing for real-time monitoring of crucial well site data, making it easy for the necessary people to make informed decisions on key issues. Ensuring the well site is as safe as possible by proactive control and maintenance of critical equipment on location.*

- ***How it will preserve existing jobs and create new ones.*** As evidenced by the current program bringing in migrant workers to fill positions, preservation of existing jobs really isn't a problem here. Quite the opposite in fact. This will ensure that all key positions can be filled, as well as creating and consolidating new ones.
- ***How it will otherwise satisfy the purposes established in the mission of the Program.*** Increased environmental awareness in the Oil and Gas industry is paramount to longevity for the industry in today's challenging environmental and political climates. The stated purpose of the CSEA is "to accelerate the transition towards a more environmentally friendly and economically viable energy sector. By providing grants and financial assistance, the CSEA aims to empower innovative projects and technologies that contribute to reducing carbon emissions, enhancing energy efficiency, and promoting renewable energy sources." The Oil and Gas industry is a bit slow when adopting new tech and SandPro has aimed to change that since its inception. Now that the CSEA is pushing toward the same goal, our interests could not be more aligned. The Smart Well Hub Checks every box on the list, and we hope that we will be selected to received grant funds to help us see the entire project come to fruition.

#### **BACKGROUND/QUALIFICIATIONS**

*Please provide a summary of prior work related to the project conducted by the applicant and other participants as well as by other organizations. This should also include summary of the experience and qualifications pertinent to the project of the applicant, key personnel, and other participants in the project.*

**Jake Feil** – CEO with 15 years of Oil and Gas business and operational experience.

**Josh Blackaby** – Vice President with extensive knowledge and a career in Health, Safety and Environment. (HSE) Josh is also an active board member with the NDPC and other Oil and Gas Committees throughout the Bakken.

**Drew Anderson**- Drew will be the project lead, as he has been on the development of these solutions thus far. Drew has 15 years industry experience, and he is also the owner of a security company that utilizes automation technologies like those that we have developed for the Oil and Gas industry.

**Logical Controls-** Logical Control Systems is a local UL Listed panel company with 10 years of experience. They have developed and deployed many innovative products all around the United States.

**Native Energy** – Native Energy is a local UL Listed panel company with 12 years of experience. They have developed and deployed many innovative products all around the United States.

**Black Pearl-** Black Pearl Technologies is a product development company for the electrical, mechanical, and software industries. The company was founded in 2018 and is headquartered in The Woodlands, Texas. Black Pearl Technologies has a team of experienced engineers and technicians who specialize in the design, development, and manufacturing of custom products for a variety of industries.

Here are some of the company's accomplishments:

- Developed a new type of LED panel that is more energy-efficient and durable than traditional LED panels.
- Developed a new type of battery that has a longer lifespan and is more environmentally friendly than traditional batteries.
- Developed a new type of software that can be used to control and monitor industrial equipment.
- Currently has technology on the International Space Station (ISS).

## MANAGEMENT

*A description of **how** the applicant will manage and oversee the project to ensure it is being carried out on schedule and in a manner that best ensures its objectives will be met, **and a description of the evaluation points to be used** during the course of the project.*

*As stated above, Drew Anderson will be the head of this project.* Drew is a highly experienced engineer with a proven track record of success in the Oil and Gas industry. He has over 15 years of experience in the design, development, and implementation of automation and control systems for Oil and Gas production facilities. Drew is also an expert in the use of data analytics to improve operational efficiency and reduce costs.

Drew is the ideal leader for the Smart Well Hub project. He has the technical expertise, the leadership skills, and the experience to successfully deliver this complex project on time and within budget.

Drew's plan (which is already in motion) to accomplish the goal of the Smart Well Hub project in 12 months is to:

1. Utilize the team of experienced engineers and technicians with the skills and expertise to design, develop, and implement the Smart Well Hub system.
2. Develop a detailed project plan that outlines the scope of work, the timeline, and the budget for the project.
3. Work closely alongside the project team with weekly meetings to ensure that the project stays on track and within budget.
4. Test and validate the Smart Well Hub solution before it is deployed in the field.
5. Provide training and support to the operators of the Smart Well Hub system.

Drew will measure the success of the Smart Well Hub project by:

1. The reduction in operational costs with less daily personnel visits.
2. Optimized Production with reduced or eliminated inadvertent shut-ins.
3. Increased safety for personnel and the environment recognized by zero incidents and spills.



## TIMETABLE

Please provide a project schedule setting forth the starting and completion dates, dates for completing major project tasks/activities, and proposed dates upon which the interim reports will be submitted.

**6-8 months to fully developed prototype.**

**10-12 months to commercialization and deployment.**

## BUDGET

Please use the table below to provide an **itemized list** of the project's capital costs; direct operating costs, including salaries; and indirect costs; and an explanation of which of these costs will be supported by the financial assistance and in what amount. The budget should identify all other committed and prospective funding sources and the amount of funding from each source. **Please feel free to add columns and rows as needed.** Higher priority will be given to projects with a high degree of matching private industry investment.

SandPro LLC	Status of Project	Total Investment Capital needed	Invested by SandPro	Remaining amount to be funded
AutoBoP	50%	\$ 200,000	\$ 20,000	\$ (180,000)
Auto Stuffing Box	50%	\$ 200,000	\$ 75,000	\$ (125,000)
Auto Stuffing Box Spill Containment	75%	\$ 20,000	\$ 5,000	\$ (15,000)
Emergency Shutdown (ESD)	100%	\$ 300,000	\$ 300,000	\$ -
The Auto Choke	90%	\$ 135,000	\$ 100,000	\$ (35,000)
Valve position monitoring on all valves	30%	\$ 100,000	\$ 20,000	\$ (80,000)
Methane detection sensors	70%	\$ 20,000	\$ 5,000	\$ (15,000)
Rod rotation sensors	70%	\$ 30,000	\$ 5,000	\$ (25,000)
Flowline live wall thickness monitoring	75%	\$ 50,000	\$ 5,000	\$ (45,000)
Temperature sensors	90%	\$ 10,000	\$ 5,000	\$ (5,000)
Pressure sensors	90%	\$ 10,000	\$ 5,000	\$ (5,000)
Labor Investment		\$ 250,000	\$ 175,000	\$ (75,000)
Facility and Tooling		\$ 650,000	\$ 550,000	\$ (100,000)
		\$ 1,975,000	\$ 1,270,000	\$ (705,000)

**It is important to note that the costing is not linear, meaning the percentage completed will not necessarily align with the amount still required.**

Submitted by: Minnkota Power Cooperative  
 Project Duration: 4 years  
 Total Project Costs: \$1,400,000,000  
 Request for: \$150,000,000 loan

**Summary of Project:** This project supports the installation of carbon capture system at the Milton R. Young Station capable of sequestering up to 4 million tons of CO<sub>2</sub> per year.

### Technical Review Results

Overall Technically Sound (275/315)	
Good	3
Fair	
Questionable	

### BND Economic Feasibility Recommendation

Overall Economic Feasibility	
Yes	X
No	

### Technical Committee Scores

	Score (Out of 50)
Charlie Gorecki	47
Josh Teigen	46
Dave Glatt	43
Lynn Helms	41
Justin Kringstad	43
Rachel Retterath	48
Todd Steinwand	49
John Weeda	49

Average: 46

**Recommendation: 8-0 Consider funding**

# TECHNICAL REVIEWERS' RATING SUMMARY

## C-04-D

Project Tundra

Submitted By: Minnkota Power Cooperative

Date of Application: May 2023

**Request for \$150,000,000 Loan**

**Total Project Costs \$1,400,000,000**

Rating Category	Weighting Factor	Technical Reviewer			Average Weighted Score
		D1 Rating	D2 Rating	D3 Rating	
1. Objectives	3	4	5	5	14
2. Impact	9	4	5	4	39
3. Methodology	9	4	4	4	36
4. Facilities	3	4	4	4	12
5. Budget	9	4	4	4	36
6. Partnerships	9	5	5	5	45
7. Awareness	3	5	4	4	13
8. Contribution	6	4	5	4	26
9. Project Management	6	4	5	4	26
10. Background	6	5	5	4	28
	315	270	291	264	275

**OVERALL TECHNICALLY SOUND**

GOOD (IF > 214)	<input checked="" type="checkbox"/>	<input checked="" type="checkbox"/>	<input checked="" type="checkbox"/>
FAIR (200-213)	<input type="checkbox"/>	<input type="checkbox"/>	<input type="checkbox"/>
QUESTIONABLE (IF < 200)	<input type="checkbox"/>	<input type="checkbox"/>	<input type="checkbox"/>

Mandatory Requirements	A1		A2		A3	
	Yes	No	Yes	No	Yes	No
Diversification Delivery:						
Project enhances the production of clean sustainable energy, to make the State a world leader in the production of clean sustainable energy, and/or to diversify and grow the State's economy.	✓		✓		✓	
Commercialization or Development/Expansion:						
Concept will lead to the <b>large-scale development and commercialization</b> of projects, processes, activities, and technologies that reduce environmental impacts and/or increase sustainability of energy production and delivery.	✓		✓		✓	

In State Requirement:	Yes	No	Yes	No	Yes	No
The funds distributed from the financial assistance are to be applied to support in-state activities and must have other sources of financial support.	✓		✓		✓	

- The objectives or goals of the proposed project with respect to clarity and consistency with Clean Sustainable Clean Energy Authority goals of projects, processes, activities, and technologies that reduce environmental impacts and increase sustainability of energy production and delivery are: 1 – very unclear; 2 – unclear; 3 – clear; 4 – very clear; or 5 – exceptionally clear.**

**Reviewer D1 (Rating 4)**

The stated objectives and those incorporated in Project Tundra are clear and consistent with CSEA goals.

**Reviewer D2 (Rating 5)**

The proposal highlights the goals and objectives including maintaining the existing jobs and economic impact of the Milton R Young Station, as well as continuing to provide reliable dispatchable power to the grid. Contribution to a net zero target in the state is also identified. These benefits are critical, and the availability of reliable and affordable power drives the entire economy of the region.

**Reviewer D3 (Rating 5)**

Project goals are clearly stated and are consistently addressed throughout the application. The environmental impact upon completion is significant and is in the best interests of the State of North Dakota and its residents. This proposal aims to create and maintain an environmentally clean energy source and has the technology and research to support it with the involvement of all of the entities listed in the application. All companies involved are well known and have been involved for some time in this project.

- The objectives will make a difference in the near term to the state’s economy: 1 – no impact; 2 – small impact; 3 – likely impact; 4 – most likely impact; or 5 – significant impact.**

**Reviewer D1 (Rating 4)**

The objectives will most likely impact the state’s economy in the near term and throughout the project construction and plant operation.

**Reviewer D2 (Rating 5)**

Not only will the project maintain existing jobs and economic benefits, additional jobs and economic activity will result throughout engineering, procurement, and construction as well as over long-term operation.

**Reviewer D3 (Rating 5)**

The initial construction phase will have significant impact on the economy of Oliver County and the State of North Dakota. The construction phase will create 600 construction jobs during the first 4 years and approximately 20-30 full time positions upon startup. All of these jobs will be

high paying positions. This project will also be a good demonstration project in developing clean energy projects elsewhere in the country.

- 3. The quality and clarity of the methodology in the proposal is: 1 – well below average; 2 – below average; 3 – average; 4 – above average; or 5 – well above average.**

**Reviewer D1 (Rating 4)**

The methodology of this proposal is above average.

**Reviewer D2 (Rating 4)**

The proposal lays out the business methodology in addition to the technology and storage aspects. The technology risk is being covered by the technology vendor.

**Reviewer D3 (Rating 4)**

This proposal is well organized and clearly describes the process as well as addressing all of the permitting requirements. In addition, it clearly describes working relations with all of those involved in the project.

- 4. The facilities and equipment available and to be purchased for the proposed pilot or commercialization strategy is: 1 – very inadequate; 2 – inadequate; 3 – adequate; 4 – notably good; or 5 – exceptionally good.**

**Reviewer D1 (Rating 4)**

The existing facilities and facilities available are notably good.

**Reviewer D2 (Rating 4)**

Equipment is available and can be purchased so this is a strength of the project. The team notes the uniqueness of the application in terms of North Dakota lignite properties, size (~2.5 times the size of Petra Nova system), and climate among others. Minnkota is performing the necessary due diligence to address these attributes.

**Reviewer D3 (Rating 4)**

The facilities appear to be adequately described with clear discussion of the process used to separate the CO<sub>2</sub> the gaseous effluent that would normally go to the stack. In addition, there is information regarding the reuse of the chemicals used to capture the CO<sub>2</sub>. there was no information regarding any waste that might be collected in the process and how it would be disposed of.

- 5. The proposed budget is comprehensive and sufficient relative to the outlined work and the timetable: 1 – not sufficient; 2 – possibly sufficient; 3 – likely sufficient; 4 – most likely sufficient; or 5 – certainly sufficient.**

**Reviewer D1 (Rating 4)**

The presented budget is most likely sufficient to accomplish the stated goals in the proposed timeframe.

**Reviewer D2 (Rating 4)**

The budget and schedule are as well thought out and addressed as can be expected at this stage in the project. The team completed the storage permits (January 2022) and is targeting completion of other key permits in 2023, to protect the schedule. They have performed the initial and intermediate design and engineering work and are working on the details. They have followed the necessary steps to protect the schedule and budget.

**Reviewer D3 (Rating 4)**

The proposed budget is briefly discussed and appears to be sufficient with funding and grants from a number of sources including grants from the US DOE and CSEA (ND). There already has been a loan of 100 million from the State of North Dakota during 2021-2023 biennium. The proposal indicates that there would be an annual payback in the amount of 24 million to the State of North Dakota annually beginning after start up of the plant.

- 6. The appropriate strategic partnerships are in place for short and long term plans to be successful: 1 – very limited; 2 – limited; 3 – adequate; 4 – better than average; or 5 – exceptional.**

**Reviewer D1 (Rating 4)**

The appropriate partnerships are in place for successful completion of short term and long term strategic goals.

**Reviewer D2 (Rating 5)**

The reviewer feels that Minnkota has done a tremendous job of assembling strong partnerships for both the technical and financial aspects of the project. The team has world class expertise directly related to the technology and the business needs of the North Dakota application.

**Reviewer D3 (Rating 5)**

There is a good discussion/description of the partnerships that includes the Milton R. Young Station, Minnkota Power Coop., Square Butte Power, and TC Energy as well as other experts on carbon capture.

- 7. The likelihood that the project approach (time & budget) will achieve its technical and market goals is: 1 – not achievable; 2 – possibly achievable; 3 – likely achievable; 4 – most likely achievable; or 5 – certainly achievable.**

**Reviewer D1 (Rating 4)**

The technical and marketing goals are most likely achievable within the restraints of the proposed time and budget estimates.

**Reviewer D2 (Rating 4)**

As stated above, the schedule and budget are well thought out and Minnkota has continued to firm them up through their efforts on working out the details.

**Reviewer D3 (Rating 3)**

Minnkota is projecting a construction start in 2024 with 4 years of construction and loan reimbursement beginning after start up and continuing for 12 years to pay off the loan.

- 8. The scientific and/or technical contribution of the proposed work to specifically address Clean Sustainable Energy Authority goals of impacting technology used in North Dakota's energy industries will likely be: 1 – extremely small; 2 – small; 3 – significant; 4 – very significant; or 5 – extremely significant.**

**Reviewer D1 (Rating 4)**

The scientific and technical contribution of the proposed work is very significant to CSEA goals and industry needs. This project addresses the most critical needs of the industry.

**Reviewer D2 (Rating 5)**

Tundra is a model fit for the CSEA program, addressing development of technology to commercial application in North Dakota reducing environmental impacts. The project increases sustainability of energy and will provide lessons learned for future North Dakota carbon management projects.

**Reviewer D3 (Rating 4)**

This carbon capture project will be a project that will remove up to 4 million metric tons per from the plant effluents and will help sustain and preserve the lignite industry in North Dakota.

- 9. The project management plan, including budgeting projections, partner connections and well-defined milestone chart is: 1 – very inadequate; 2 – inadequate; 3 – adequate; 4 – notably good; or 5 – exceptionally good.**

**Reviewer D1 (Rating 4)**

The project plan is notably good yet could be improved with additional graphics.

**Reviewer D2 (Rating 5)**

The project management laid out by Minnkota is designed to optimize the project using their own team as well as their strategic partnerships.

**Reviewer D3 (Rating 4)**

Charts included in this proposal include funding sources, how funds will be used, and an after-tax cash flow chart.

- 10. The background and experience of the project principals with regards to technical qualifications and competence is: 1 – very limited; 2 – limited; 3 – adequate; 4 – better than average; or 5 – exceptional.**

**Reviewer D1 (Rating 4)**

The background and experience of the principals is better than average as Project Tundra has grown so has the background and experience of the principals grown.

**Reviewer D2 (Rating 5)**

This is a strength of the proposal. Minnkota themselves have moved forward in a stepwise fashion addressing any uncertainties throughout. In addition, they have put together a technical team with direct experience in carbon capture and have proceeded the same way with their business plan.

**Reviewer D3 (Rating 5)**

The partners in this project appear to be well qualified and experienced nationally and internationally and have considerable experience in the lignite industry. In addition, those companies named to be part of the construction phase of the project are nationally known and have a vast amount of experience.

---

**Section C. Overall Comments and Recommendations:**

**Please comment in a general way about the merits and flaws of the proposed project and make a recommendation whether or not the project is technically sound.**

**Reviewer D1**

This project is technically sound. The project's most significant merit is the ability of the project to satisfy the needs of the industry. The project meets perceived and actual needs of society, government, and the industry. This is an excellent proposal.

**Reviewer D2**

This reviewer strongly recommends the funding be approved. As stated above, this project is a model fit for CSEA. Minnkota and their strategic partners have performed detailed evaluations to maximize the opportunity for commercial success. This project will lead the way for other similar projects. It is an important step to maintaining and growing the economic impact of the lignite industry while dealing with challenges associated with carbon management and a changing grid.

**Reviewer D3**

Technically, the project appears involving those companies that are well grounded in technical knowledge related to the chemistry of the lignite industry. Maybe there could be more information regarding how the CSEA funding has been used and how the additional funding will be used.





A Touchstone Energy® Cooperative 

5301 32nd Ave S  
Grand Forks, ND 58201-3312

Phone 701.795.4000  
[www.minnkota.com](http://www.minnkota.com)

May 18, 2023

Clean Sustainable Energy Authority  
North Dakota Industrial Commission  
State Capitol – 14th Floor  
600 East Boulevard Ave Dept 405  
Bismarck, ND 58505-0840

**Subject: Project Tundra CSEA Application**

Dear Clean Sustainable Energy Authority:

Minnkota Power Cooperative is pleased to submit an electronic copy of its Project Tundra Clean Sustainable Energy Authority (CSEA) application. An original and one copy of the subject proposal will also be submitted by mail.

Enclosed you will find an application for a \$150 million loan through the CSEA to support the commercialization of a transformational technology that will provide widespread benefits to the lignite industry. The Project Tundra team is committed and ready to complete the project as described in the proposal with the support of the CSEA. The goal of Project Tundra is to demonstrate post combustion carbon capture (PCCC) and storage in North Dakota, preserving the use of lignite and the associated jobs, ensuring enough reliable and dispatchable power is on our grid, and moving North Dakota closer to its carbon neutral goal.

If you have any questions, please contact me by phone at (701) 795-4204 or by email at [asorbo@minnkota.com](mailto:asorbo@minnkota.com)

Sincerely,

A handwritten signature in blue ink that reads "Andrew C. Sorbo". The signature is fluid and cursive, with a long, sweeping underline that extends to the right.

Andrew C. Sorbo  
Minnkota Vice President of Strategic Initiatives

*Minnkota has expended resources to develop the investment structure and determine its feasibility for tax equity investment and structured project finance. Because of the nature of this project and the tax credit market, other projects would gain significant value and advantage in the competitive investment markets if the structure were disclosed publicly.*

**5. A Description of the Efforts Used to Maintain the Secrecy of the Information.**

*To protect all project participant proprietary business information, Minnkota employs strict confidential policies and procedures for handling and maintaining its, or its partners', confidential, proprietary, and trade secret information. The information is not disclosed outside the project team. The information is only disclosed to those people needing the information to perform the roles and responsibilities directly leading to development of the project.*

*Financial structure and proprietary business information is only disclosed to a very select number of the qualified investor pool. Further, for both technical or financial proprietary and trade secret information, Minnkota requires that those few select entities and individuals receiving such information to be bound by stringent confidentiality terms and conditions.*

*Any deliverables (presentations, documents and reports) derived from this proposed project will only contain nonconfidential information, which will allow public review of the project without compromising confidential information.*

## APPLICATION CHECKLIST

*Use this checklist as a tool to ensure that you have all of the components of the application package. Please note, this checklist is for your use only and does not need to be included in the package.*

<input type="checkbox"/>	Application
<input type="checkbox"/>	Transmittal Letter
<input type="checkbox"/>	Tax Liability Statement
<input type="checkbox"/>	Letters of Support (If Applicable)
<input type="checkbox"/>	Confidentiality Request
<input type="checkbox"/>	Business Plan (Appendix)
<input type="checkbox"/>	Historical Financial Statements (3 years) (Appendix)
<input type="checkbox"/>	Budgeted Projections (Appendix)
<input type="checkbox"/>	Loan/Loan Guarantee Application (if Applicable, Appendix)
<input type="checkbox"/>	Other Appendices (If Applicable)

When the package is completed, send an electronic version to [sustainableenergy@nd.gov](mailto:sustainableenergy@nd.gov) and 2 hard copies by mail to:

Clean Sustainable Energy Authority  
North Dakota Industrial Commission  
State Capitol – 14th Floor  
600 East Boulevard Ave Dept 405  
Bismarck, ND 58505-0840

For more information on the application process please visit:  
<http://www.nd.gov/ndic/csea-infopage.htm>

Questions can be addressed to Al Anderson (701) 595-9668.

Clean Sustainable Energy Authority  

---

North Dakota Industrial Commission

## Application

**Project Title: Project Tundra**

**Applicant: Minnkota Power Cooperative**

**Date of Application: May 18, 2023**

**Amount of Request**

**Grant:**

**Loan: Up to \$150,000,000 additional for  
a total of \$250,000,000**

**Total Amount of Proposed Project: \$1,400,000,000**

**Duration of Project: Construction – 4 years**

**Operations – 20 years**

**Point of Contact (POC):**

**Andrew C. Sorbo, Minnkota Power Cooperative  
Vice President of Strategic Initiatives**

**POC Telephone: 701-795-4204**

**POC Email: [asorbo@minnkota.com](mailto:asorbo@minnkota.com)**

**POC Address: 5301 32<sup>nd</sup> Ave. South  
Grand Forks, ND 58201**

## TABLE OF CONTENTS

*Please use this table to fill in the correct corresponding page number.*

<b>Abstract</b>	<b>9</b>
<b>Project Description</b>	<b>10</b>
<b>Anticipated Results</b>	<b>14</b>
<b>Standards of Success</b>	<b>27</b>
<b>Background/Qualifications</b>	<b>29</b>
<b>Management</b>	<b>46</b>
<b>Timetable</b>	<b>47</b>
<b>Budget</b>	<b>48</b>
<b>Patents/Rights to Technical Data</b>	<b>49</b>
<b>State Programs and Incentives</b>	<b>49</b>
<b>Appendix A: Confidential Information</b>	<b>51</b>

## ABSTRACT

**Objective:** The goal of Project Tundra is to demonstrate post combustion carbon capture (PCCC) and carbon dioxide storage in North Dakota, preserving the use of lignite and the associated jobs, ensuring enough reliable and dispatchable power is on our grid, and moving North Dakota closer to its carbon neutral goal. Minnkota plans to transform the MRYS, a critically important dispatchable energy resource, while also maintaining the existing high-paying jobs and essential economic impact for the local communities and surrounding region as the US transitions to low-carbon energy through policy changes, regulatory requirements, or other mechanisms. MRYS has dispatched at more than a 90% average running plant capacity factor over the past five years in the competitive Midcontinent Independent System Operator (MISO) electric market, which demonstrates its favorable production cost relative to the market. MRYS operates at a predictable cost, and has performed reliably through recent market volatility, protecting the member-owners of Minnkota from financial risk and exposure to high-priced energy markets.

At a design capacity of up to 4,000,000 metric tons per year, Project Tundra will be the largest single-train PCCC in the world that will feature a “station” approach to carbon dioxide (CO<sub>2</sub>) emissions control as opposed to the “dedicated unit” configuration being proposed by the rest of the industry. The additional commitment requested in this application coupled with the prior amount authorized will pave the way for Minnkota to raise the additional capital needed for a possible start of construction for Project Tundra by the end of Q1- Q2 2024.

**Expected Results:** A commitment from the Clean Sustainable Energy Authority (CSEA) for the requested additional \$150 million for a total \$250 million low-interest loan will help close the gap and demonstrate that Project Tundra is worthy of consideration by other potential investors.

Past support from the NDIC has directly funded Project Tundra research and development activities, along with grants from the U.S. Department of Energy. That support coupled with a strong CSEA commitment has enabled Minnkota Power Cooperative Inc. (Minnkota) to (a) finalize and complete the design, (b) attract private investors to fund the remaining development and commit hundreds of millions in project equity, and (c) complete all facets and details needed for the project to go into construction in Q1- Q2 of 2024.

**Duration:** Construction of Project Tundra is estimated to take four years to complete. The operating life thereafter is designed for at least 20 years.

**Total Project Cost:** Construction and commissioning costs of the PCCC and supporting balance of plant is estimated at \$1.30 billion. The adjacent CO<sub>2</sub> storage facility is anticipated to cost an estimated \$100 million to be ready to start receiving CO<sub>2</sub>. See Sources and Uses within the Confidential Appendix A.

**Participants:** Minnkota is the project sponsor and will be a partner in the ownership of the project. We expect the U.S. Department of Energy will participate in funding capital cost of the project through direct demonstration grants.

Minnkota, with the assistance of Sargent & Lundy who will be the Owner's Engineer, will provide overall construction management on behalf of the project owners and lenders for both the PCCC and the CO<sub>2</sub> storage facility.

## **PROJECT DESCRIPTION**

**Objectives:** Project Tundra is an initiative to build the world's largest post-combustion carbon dioxide (CO<sub>2</sub>) capture facility at the existing Milton R. Young Station (MRYS), a lignite-based power plant in North Dakota. The proposed project is designed to capture up to 4 million metric

tons of CO<sub>2</sub> annually from MRYS. The captured CO<sub>2</sub> will be safely and permanently stored in geologic formations approximately 5,000 and 9,000 feet underground directly under the MRYS.

The proposed project is being developed by Minnkota Power Cooperative, Inc.<sup>1</sup> (Minnkota), a regional generation and transmission cooperative that provides wholesale power to 11 member-owner distribution cooperatives in eastern North Dakota and northwestern Minnesota. Minnkota is the operator of the two-unit MRYS. The MRYS is a valuable asset for Minnkota due to its reliable, resilient, and cost-competitive operating characteristics. MRYS has dispatched at over 90% average capacity factor over the past five years in the competitive Midcontinent Independent System Operator (MISO) electric market, which demonstrates its favorable production cost relative to the market. However, it is anticipated that the facility has the potential to face a carbon-constrained or carbon-managed future through policy changes, regulatory requirements, or other mechanisms. Project Tundra will help preserve this important power resource for Minnkota's cooperative members, while also maintaining the existing high-paying jobs and essential economic impact for the local communities and surrounding region. The MRYS and adjacent lignite mine are the largest employers in Oliver County and according to data from the North Dakota Job Service, Oliver County had the second-highest average annual wages in the state in 2022.

## **Methodology**

The economics of the proposed project are based on:

- The Internal Revenue Service Section 45Q federal tax credit program, which will provide a tax credit of \$85/tonne of CO<sub>2</sub> captured and permanently sequestered in secure geologic

---

<sup>1</sup> [www.minnkota.com](http://www.minnkota.com)



storage. The period during which tax credits can be claimed is 12 years from the start of commercial operation and the value of the credits is indexed to inflation, which in the project's model increases the credits to over \$100/tonne at the end the 12-year period. The law also provides for not-for-profits like electric cooperatives to receive "direct pay" payments from the IRS instead of tax credits on a 1:1 basis. For-profit companies may also receive direct pay for the first 5 years of operations and then for the remaining 7 years it reverts to tax credits;

- Under our equity structure, Minnkota's partners will not only be able to monetize their share of the 45Q tax credits (after the direct pay period), but they will also monetize Minnkota's share of other tax attributes. Together, the direct pay and the monetized value of the other tax attributes create a strong and very creditworthy revenue stream for the project participants that would underpin repayment of a CSEA-backed loan. A more detailed live cash flow model showing revenue streams using multiple base-case runs will be discussed within the confidential Appendix A. The actual live cash flow model will be provided to the Bank of North Dakota directly in conjunction with this application.

StorageCo will be owned by a joint venture company which in turn is owned by Minnkota and its partner(s).

The \$1.40 billion in costs for CaptureCo and StorageCo will be funded by equity contributions from Minnkota and its partner(s), potential DOE grants, and a loan through CSEA. The CSEA funds play a critical role within the project's overall capital stack. Project Tundra holds three main risks for investors: technology, storage, and capital. The technology risk is covered by the chosen technology vendor. The storage risk is mitigated by the State of North Dakota's leadership in holding primacy over required permitting, leading Minnkota to now hold the nation's largest Class

VI Storage permit and an approved Environmental Protection Agency (EPA) Monitoring, Reporting and Verification (MRV) plan. These projects, while promising, still require enormous federal and state support on financing to attract the necessary private capital investment. Even with the enhancement of 45Q, inflation and scale-up risk still necessitate state support to offset capital risk. The capital risk of a project of this magnitude will only be mitigated by decreased capital spend, as the potential returns are driven off performance, not investment levels. This reduced capital spend takes several forms: an acceptable Engineering, Procurement, and Construction (EPC) cost, DOE funds, private funds raised by Minnkota, and CSEA funds.

In the base case, \$3.8 billion in total direct pay and tax credits plus \$700 million in monetized other tax attributes combine for \$4.5 billion in cash available during the first 12 years of operations. During those years that cash will be used for:

- \$2.3 billion to pay for operating costs
- \$2.2 billion in distributions to pay back the \$1.40 billion investment, cover interest payments and provide a return to investors.

After the first 12 years of operations during which the CSEA loan will be repaid and equity investors will achieve their target returns, the project owners will evaluate the market conditions to determine how to operate the facility in the then-current environment.

To complete the remaining development work needed to close on the financing described above and begin construction, the project development team will need to complete the following by December 2023: **1)** the final construction-ready design for the CO<sub>2</sub> capture plant and the short on-site CO<sub>2</sub> pipeline; **2)** final, firm contract offers for the CO<sub>2</sub> capture plant, CO<sub>2</sub> pipeline, and

the CO<sub>2</sub> geologic storage facility; **3)** have a firm budget for the operating costs for all project components, and **4)** have all permits in hand, including the Class VI drilling and storage permits.

## **ANTICIPATED RESULTS**

### *CO<sub>2</sub> Capture Plant:*

Unique features of the proposed CO<sub>2</sub> capture plant include:

- The Technology Provider's most advanced capture technology, which brings much needed commercial-ready technology to the carbon capture industry.
- Demonstrating CCS on coal-fired flue gas at full utility-scale with an increase of 2.5X compared to the largest existing similar project, Petra Nova.
- The proposed project will capture and store up to 4 million tonnes per year of CO<sub>2</sub>.
- The first time CCS technology will be applied on lignite coal flue gas demonstrating methods to mitigate challenges unique to lignite (in particular North Dakota lignite), including ultrafine particulate produced during lignite combustion.
- The project will demonstrate construction and operation methods for the North Dakota climate with design strategies to mitigate the impact of cold weather on a process and piping that runs with large volumes of water.
- A steam supply source extracted from multiple units simultaneously.
- The project will demonstrate a "station" approach to carbon capture by simultaneously drawing flue gas from two lignite boilers into one carbon capture system showing that CCS technology is capable of decarbonizing the power production of multiple units at one station.

### *CO<sub>2</sub> Geologic Storage Facility:*

As with the CO<sub>2</sub> capture plant/technology, Project Tundra includes unique, new, and innovative features in the geologic storage component. These are summarized below:

- An estimated 4X increase, in terms of volume of CO<sub>2</sub> injected, over the next largest existing saline formation geologic storage project in the U.S. (ADM Decatur project).
- First multi-million tonne per annum commercial geologic storage project in North Dakota.
- Use of “stacked storage” that involves the injection and storage of CO<sub>2</sub> into multiple geologic horizons. This design optimization minimizes the aerial extent of the CO<sub>2</sub> pool in the subsurface.

### **Facilities**

Minnkota is a regional generation and transmission cooperative headquartered in Grand Forks, ND, providing wholesale power to 11 member-owner rural electric distribution cooperatives.

Minnkota is also affiliated with Northern Municipal Power Agency (NMPA), which serves the electric needs of 12 municipalities in the same geographic region as the Minnkota member-owners. Minnkota serves as the operating agent of NMPA. Figure 1 provides a map showing the Minnkota and NMPA service territory.

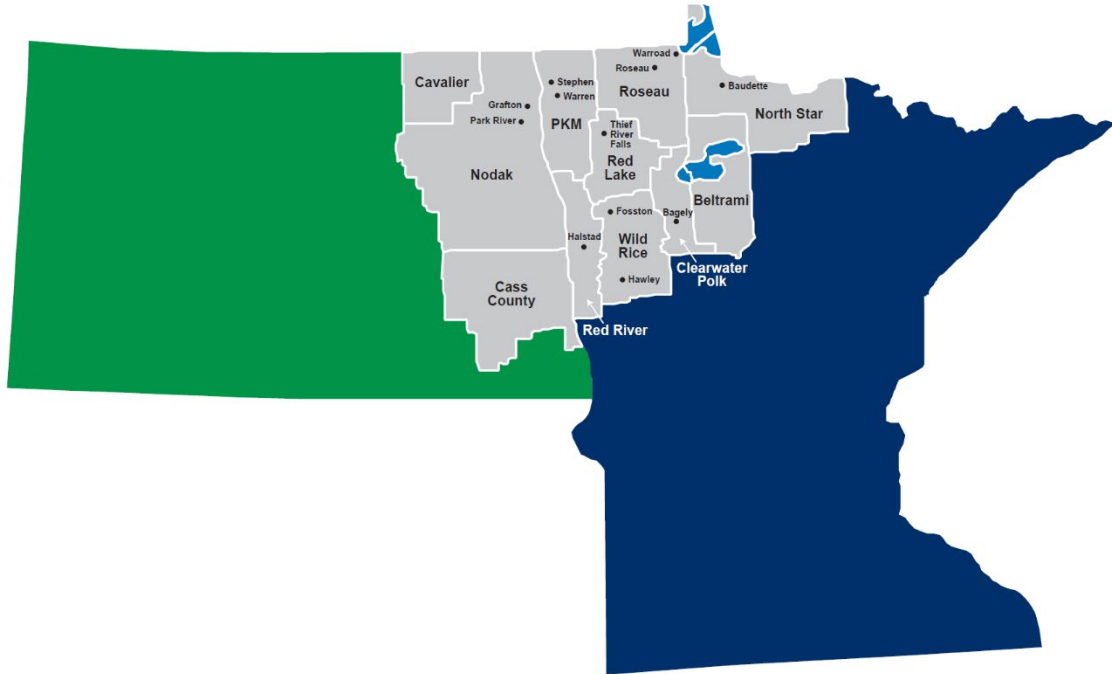

Figure 1. Minnkota-NMPA Service Territory

Minnkota’s primary firm and dispatchable generating resource is the two-unit Milton R. Young Station (MRYS), a lignite coal-fired power plant in North Dakota and the host plant for the proposed carbon dioxide (CO<sub>2</sub>) capture and geologic storage project. Unit 1 at MRYS is owned and operated by Minnkota. Unit 2 at MRYS is owned by Square Butte Electric Cooperative (Square Butte) and as Square Butte’s operating agent, Minnkota operates Unit 2. Square Butte has the same 11 member-owners as Minnkota (but has a separate set of individuals from the 11 member-owners sitting on the board of directors) and only has one employee, the General Manager, who is also the President & CEO of Minnkota.

## Resources

### A. Amount of Expected Equity Investments

The Borrower (Minnkota) expects that in order to raise equity for the project a sponsor equity contribution is needed from Minnkota. The balance of the \$1.40 billion capital

needed for the PCCC system plus the capital needed for the CO<sub>2</sub> storage facility will be sourced from other equity sponsors with large tax capacities and from demonstration grants from the U.S. Department of Energy.

**B. Preliminary Funding Plan for Guaranteed Obligation**

The Guaranteed Obligation will be a loan in the amount of \$250 million (\$100 million CSEA commitment made in the 2021-23 biennium, plus the \$150 million CSEA commitment we are seeking in the 2023-2025 biennium) made to the project company, which will be the owner of the PCCC system. Minnkota, and the ultimate project company, will work closely with the Bank of North Dakota to provide an appropriate collateral package. Potential structures are predominantly driven off developing the most tax efficient structure to prevent leakage.

**C. Timing of Equity Contributions and Debt Funding**

The Borrower contemplates there will either be a construction loan facility with a guaranteed take-out commitment (upon final commercial operation of the project) from construction lenders or the entire construction funding will come from equity partners, called upon pro-rata to equity positions during the construction period.

**D. Timing of Debt Repayment**

The Borrower expects the term of the debt to be 12 years from the time the project commences commercial operations. The payments are expected to be “sculpted” over the term to maintain agreed coverage ratios while considering variations in free cash flow due to operations and maintenance cycles of the capture system and MRYS. A potential model describing debt structure and repayment of the CSEA loan is further described within the confidential Appendix A.

## **E. Federal Support**

To date the project has received several grants, including approximately \$33 million (\$16.9M-CarbonSAFE, \$9.8M-DOE-NETL for the FEED Study and \$6M for Project Carbon 1 and 2, Pre-FEED and Pilot Test) in direct federal Department of Energy grants to advance this project to construction. The bipartisan effort to pass §45Q tax credit reform recognizes the important role carbon capture will play in the nation and world. Carbon capture projects are capital intensive, and there is a recognition that early movers of projects, such as this one, will require enhanced support to get to construction as evidenced by not only raising the value of §45Q but also the authorization of large demonstration grants enacted by Congress. In the alternative of not receiving a large grant through the infrastructure package, an existing loan guarantee program through the DOE serves as a further opportunity to raise capital through low-cost financing. Minnkota has explored the application process for this loan program and has passed the first phase of the DOE's diligence in an effort to keep all capital stack options open. These programs are not additive, thus, if the project receives a grant from the DOE, the proposed project would not be eligible for a federal loan guarantee or vice versa. In either case, these programs are needed to improve the economics of the project and there is much optimism about the proposed project's competitive edge to capture one of the large federal demonstration grants or qualify for the loan guarantee program. Additionally, the Inflation Reduction Act created a new voluntary \$9.7 billion grant and loan program designed specifically for electric cooperatives that purchase or build new clean energy systems, which includes carbon capture technology. On May 15, 2023, USDA published the Notice of Funding Opportunity Announcement in the Federal Register, starting a

short timeline for interested co-ops to pursue these funds. Minnkota will explore opportunities through this program, but it is currently considered a second option behind the Department of Energy grant.

#### **F. Other Non-federal Support/Incentives**

At this time, there are no other non-federal government-direct financial incentives available for the construction of the proposed project or during operations other than the CSEA loan program. There are, however, several indirect forms of financial support from North Dakota, such as tax incentives, that will benefit the project. These are listed in Table 1 along with their citations to the North Dakota Century Code. Note that some of these incentives are only applicable to enhanced oil recovery (EOR) projects. EOR is not currently part of the proposed project but may represent an opportunity in the future.

**Table 1.** *ND tax incentives for CCUS (ND Century Code Chapters 57-39.2, 57-40.2, 57-51.1, 57-60)*

- 
- Sales and use tax exemption for CO<sub>2</sub> equipment to compress, gather, collect, store, transport, or inject CO<sub>2</sub>.
  - CO<sub>2</sub> capture equipment on a coal (or other) facility is considered personal property, exempt from property tax.
  - Oil extraction tax exemptions for incremental production from a secondary or tertiary recovery project.
  - Sales and use tax exemption for CO<sub>2</sub> used for EOR.
  - CO<sub>2</sub> equipment at a wellsite is considered personal property, exempt from property tax.
  - CO<sub>2</sub> capture system exemption from ad valorem and coal conversion facilities privilege tax.
  - Sales and use tax exemption for environmental upgrade materials used in power plants and processing plants.
  - Property tax exemption for pipeline property and associated transportation and storage equipment used for EOR.
  - Coal conversion facilities privilege tax credit for CO<sub>2</sub> capture.
- 

#### **Techniques to be used, their availability and capability:**

This section of the application provides the detailed technical information for the proposed project.



## **Description of Project Design**

There are three major components to the proposed project: 1) the PCCC or CO<sub>2</sub> capture plant, 2) the 0.25 mile CO<sub>2</sub> pipeline, and 3) the CO<sub>2</sub> geologic storage facility. This section will provide information on the basic processes involved in the design of each.

### **CO<sub>2</sub> Capture Plant**

Figure 2 provides a simplified block flow diagram of the major processes involved in the CO<sub>2</sub> capture plant and how they are integrated with the existing MRYS. As shown, both Unit 1 and Unit 2 are available to provide flue gas to the capture plant. Normal operation involves 100% of Unit 2 and 20% of Unit 1 flue gas being routed to the capture plant with the balance being routed to its existing chimney. During Unit 2 outages, 100% of Unit 1 will be available to feed the capture plant. Unit 2 flue gas can also be routed to its existing chimney during startup/shutdown or during capture plant outages. Flexibility in the design will also allow 100% of the Unit 1 flue gas to be routed to the capture plant with the remaining coming from Unit 2 to utilize the full capacity of the facility.

The capture plant requires a significant quantity of steam for solvent regeneration. This will be provided by extracting steam from the Unit 1 and 2 steam turbines. A unique feature of the proposed project, as described previously, is that flue gas from both coal-fired units along with extracted steam from both units will be routed to the capture system simultaneously.

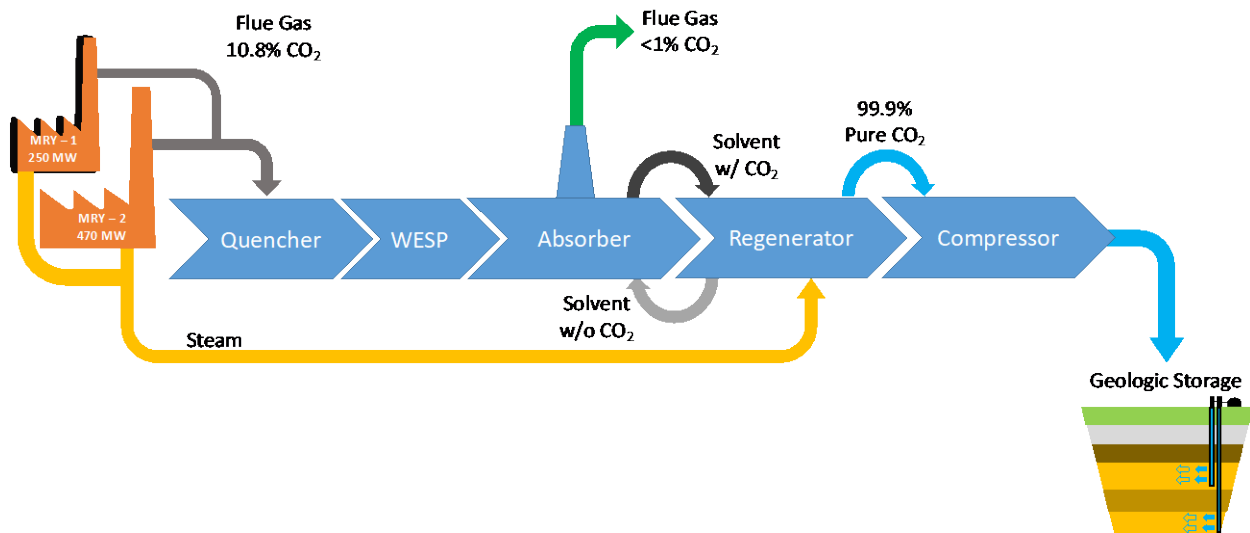

**Figure 2.** Block flow diagram for the CO<sub>2</sub> capture plant and its integration with the existing MRYS. During normal operation, 100% of Unit 2 flue gas and 20% of Unit 1 flue gas is routed to the capture plant. Unit 1 flue gas is available to feed the capture plant during Unit 2 outages. Both units will provide steam required for the amine solvent regeneration and provide flue gas that feeds the capture system.

#### Summary of Carbon Capture Process:

The technology (generalized schematic in Figure 3) is an advanced amine-based process specialized for removal of CO<sub>2</sub> from low pressure, oxygen-containing flue gas. The basic plant configuration consists of: **1)** a 2-stage Direct Contact Cooler (DCC) for flue gas cooling and SO<sub>2</sub> removal, **2)** an Absorber for CO<sub>2</sub> separation, **3)** a Regenerator for solvent regeneration and the release of pure CO<sub>2</sub>, and **4)** a compression and dehydration system to supply pipeline-ready CO<sub>2</sub> at the fence line. The process begins in the DCC for flue gas conditioning. Then, as the conditioned flue gas flows up the Absorber, CO<sub>2</sub> is chemically absorbed into a circulating solvent stream flowing down the column.

The CO<sub>2</sub>-loaded solvent is then pumped from the bottom of the Absorber, through a heat recovery exchanger where it is heated against hot CO<sub>2</sub>-lean solvent, and into the top of the Regenerator. As the solvent flows down the Regenerator, it is contacted by steam, which strips the CO<sub>2</sub> from the solvent, producing an overhead mixture of steam and CO<sub>2</sub>. The steam/CO<sub>2</sub>

product is cooled and the steam is condensed and separated from the CO<sub>2</sub> product. Hot CO<sub>2</sub>-lean solvent from the bottom of the Regenerator is pumped back through the heat recovery exchanger where it is cooled against the cold CO<sub>2</sub>-loaded solvent before being returned to the top of the Absorber. Although not part of the standard flow sheet, for the Tundra project a wet electrostatic precipitator (WESP) is also included in the process design (see Figure 2). This is due to challenges unique to the application of the proposed project on North Dakota lignite flue gas.

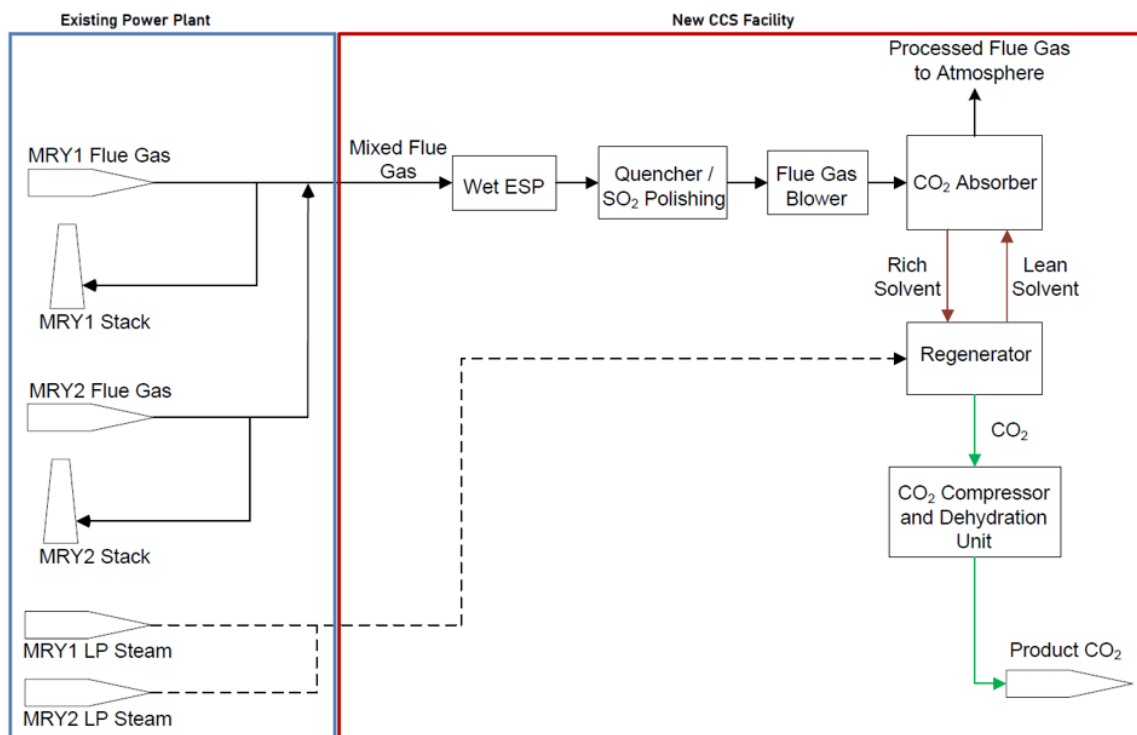

**Figure 3.** Generalized schematic of the Project Tundra CO<sub>2</sub> capture technology

## CO<sub>2</sub> Pipeline

In 2021, Burns & McDonnell completed a Front-End Engineering and Design (FEED) study for the CO<sub>2</sub> pipeline. Building on this FEED study, Minnkota has been assisted by Sargent & Lundy and Baker Hughes, who are currently in the process of design and engineering for the CO<sub>2</sub> pipeline. The proposed project currently contemplates one CO<sub>2</sub> injection well pad, which would

contain up to three injection wells. The well pad is located 0.25 miles to the south of MRYS. The CO<sub>2</sub> pipeline and its associated infrastructure and instrumentation will enable transport and metering of the captured and compressed CO<sub>2</sub> from the capture plant to the injection wells.

A common metering station will be located at the boundary limit of the CO<sub>2</sub> capture plant and one 16-inch (OD) underground pipeline will transport the CO<sub>2</sub> in a dense phase to the well pad location.

The well pad will include its own metering station. No pump stations or mainline valves are expected to be required; the CO<sub>2</sub> compressor located at the CO<sub>2</sub> capture plant is being designed to provide all of the pressure needed to accommodate the pipeline pressure drop and the hydrostatic injection pressure for the Broom Creek geologic formation where the majority of the CO<sub>2</sub> is planned to be stored. If needed, an injection booster pump will be installed to enable injection in the Deadwood formation, the deeper formation with higher pressure of the two target formations.

Although the proposed project does not contemplate selling CO<sub>2</sub> for enhanced oil recovery (EOR), a tie-in point will be included in the design in the event a market for CO<sub>2</sub>-EOR develops in the future.

### **CO<sub>2</sub> Geologic Storage Facility**

The proposed project targets dedicated CO<sub>2</sub> geologic storage in multiple saline formations beneath the MRYS and the adjacent lignite mine. Dedicated storage is possible in sedimentary basins where there are layers of porous and permeable rocks (i.e., sandstone) that are sealed above and below by impermeable caprocks (i.e., shale). The proposed project overlies the Williston Basin and there are multiple suitable layers for dedicated geologic storage. Figure 4

provides the stratigraphic column underlying the proposed project area and notes the lowest underground source of drinking water (USDW) and three geologic horizons that are currently being characterized by the project team for injection and storage of the captured CO<sub>2</sub>.

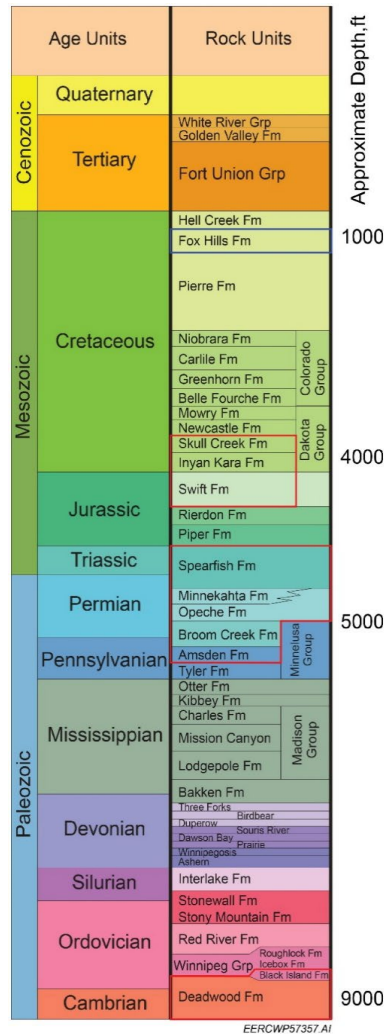

**Figure 4.** Stratigraphic column underlying the area near the proposed project. The lowest USDW (Fox Hills) and the three target formations (Inyan Kara, Broom Creek, Deadwood) and their overlying and underlying cap rocks are highlighted.

Minnkota worked with the Energy & Environmental Research Center (EERC) in developing the proposed plan for the Project Tundra storage site (Tundra SGS). The storage facility permit and Class VI drilling permit were issued by the North Dakota Industrial Commission on January 21, 2022, NDIC Order No. 31583-31588. The proposed storage development consists of two phases

beginning with Phase 1 CO<sub>2</sub> storage operations in the Broom Creek Formation. Two wells are proposed for Phase 1 into the Broom Creek Formation. Upon construction and operation of those two wells, an assessment will be made of their operational capabilities to determine whether there is a need for additional capacity. If needed, Phase 2 of development would commence, which includes the construction and operation of one additional well and the booster pump for injection into the Black Island–Deadwood Formation. There are a number of contingency options available for fine-tuning injection operations such as a possible construction of a third injection well into the Broom Creek if needed.

### **Environmental and Economic Impacts while Project is Underway**

#### *Impact on Environment/Greenhouse Gas Emissions*

The proposed project is a post-combustion CO<sub>2</sub> capture and storage project that will capture and geologically store up to 4 million tonnes/year of CO<sub>2</sub>. There are two sources of CO<sub>2</sub> for this project. The design specification is that more than 90% of the CO<sub>2</sub> in the Unit 2 and Unit 1 flue gas entering the capture plant will be captured during normal operation (Unit 2 at 100% of its total flue gas flow while 20% of Unit 1's total flue gas flow) and only 100% of either Unit 1 or Unit 2 when one is in an outage.

When considering planned outages on each of the units (3-5 short cleaning outages per year and one major maintenance outage every 3 years), provided below is the maximum total contribution of captured CO<sub>2</sub> from each of the sources.

- Unit 2 at MRYS (455 MW) – 3.20 million tonnes/year
- Unit 1 at MRYS (250 MW) – 0.80 million tonnes/year
- Total CO<sub>2</sub> captured and sequestered – 4.0 million tonnes/year

## **Ultimate Technological and Economic Impacts**

### *Economic Impacts*

One of the primary motivating factors for Minnkota's pursuit of the proposed project is preserving the MRYS in the face of a likely carbon-managed future and the availability now of federal and state programs to offset the cost of installation and operation. The MRYS today employs approximately 170 people and the associated Center Mine employs approximately 180 more. The average salary for employees of the MRYS and Center Mine is more than \$100,000, significantly higher than the state average of \$60,215.<sup>2</sup> If the MRYS and the Center Mine (MRYS is its only customer) were forced to retire early (years ahead of their useful lives), as with numerous other coal plants and mines in the U.S., the negative economic impact on Oliver County and the State of North Dakota would be tremendous.<sup>2</sup> Additionally, the cost of an early facility closure has a complex impact to Minnkota, including likely having to raise electric rates for tens of thousands of North Dakotans and Minnesotans served by Minnkota's member-owners. Minnkota and its members serve a diverse consumer base, including agricultural centers, rural areas and many low-income communities. Conversely, Minnkota's service territory also includes the growing areas of Fargo and Grand Forks, where the price of electricity is directly tied to their economic competitiveness regionally and nationally.

### **Why the Project is Needed**

One of the key drivers for the proposed project is the continued utilization of the MRYS in the face of a likely carbon managed future. MRYS is a valuable asset for Minnkota providing low-cost, reliable baseload power that has proven to be dependable and resilient – no matter if it is

---

<sup>2</sup> [https://www.ndlmi.com/admin/gsipub/htmlarea/uploads/lmi\\_empwagesind2022.pdf](https://www.ndlmi.com/admin/gsipub/htmlarea/uploads/lmi_empwagesind2022.pdf)

100 degrees or 30-below-zero Fahrenheit. The proposed project will also preserve the high-paying jobs and essential economic impact in the local communities and surrounding region. MRYS has dispatched at over 90% average capacity factor over the past five years in the MISO electric market, which demonstrates its competitive production cost and important role the electric market.

## **STANDARDS OF SUCCESS**

The standards by which the success of the project is to be measured.

### **A. Emissions reduction**

The proposed project will capture and geologically store up to 4 million tons/year of CO<sub>2</sub>, and achieve an additional reduction of approximately 200 tons/year of particulate and approximately 2,000 tons/year of SO<sub>2</sub> that would otherwise be emitted to the atmosphere.

### **B. Increased energy sustainability**

The project provides a low-carbon source of dispatchable, reliable electric capacity that provides grid stability, particularly with an increasingly strained grid.

### **C. Value to North Dakota**

North Dakota has the opportunity to lead the region, nation and world on not only reducing carbon emissions, but also in developing new carbon markets. Project Tundra represents an enormous advancement of technology to capture and safely store emissions. Preservation of reliable electric baseload assets is of tantamount importance in this project, but also represents potential future opportunity of enhanced oil recovery, greenhouse development and other utilization opportunities in the state.



**D. Explanation of how the public and private sector will make use of the project's results, and when and in what way**

The learnings and confidence gained from a successful demonstration of this project will help make follow-on projects more successful and give capital markets more confidence to invest in this space.

**E. The potential commercialization of the project's results**

This project can help serve as a blueprint for carbon capture technology on other coal-fired power plants, gas-fired plants and other industrial processes. The potential advancement of this technology will require multiple vendors and will benefit from competition.

**F. How the project will enhance the research, development and technologies that reduce environmental impacts and increase sustainability of energy production and delivery of North Dakota's energy resources**

The project will be the largest postcombustion carbon capture project in the world and will demonstrate that coal has a place in the low-carbon energy market the industry is transitioning toward. Further, the availability of large volumes of CO<sub>2</sub> for future EOR activities in North Dakota's oil fields (including possibly the Bakken) sets the stage for the state's produced oil to be certified with a lower carbon intensity than most oil on the market today.

**G. How it will preserve existing jobs and create new ones**

The proposed project is expected not only to preserve the high paying jobs for the 350 direct employees of the MRYS and Center Mine (not to mention the many indirect jobs that support ND's lignite industry), it is expected to add up to 600 additional high-paying

construction (temporary) and 20-30 new permanent jobs. Minnkota is presently working with the Bank of North Dakota and FTI Consulting to develop a Regional Economic Models, Inc. (REMI) model to identify the deeper positive economic impacts of Project Tundra.

#### **H. How it will otherwise satisfy the purposes established in the mission of the Program**

The outlined purpose of the CSEA program is to support research, development and technological advancements through partnerships and financial support for projects ready for commercialization that reduce environmental impacts. Project Tundra brings together each part of that mission, for all the reasons previously stated in this application. If constructed, this project would play a critical role in current and future energy production, natural resource development, environmental stewardship, while also preserving and enhancing jobs in the state.

### **BACKGROUND/QUALIFICATIONS**

*Please provide a summary of prior work related to the project conducted by the applicant and other participants as well as by other organizations. **This should also include summary of the experience and qualifications pertinent to the project of the applicant, key personnel, and other participants in the project.***

#### **Project Sponsor Capabilities and Qualifications**

The Project Sponsor, Minnkota, has the experience, expertise, and wherewithal to develop, finance, construct, and operate this project successfully. Minnkota owns and operates MRYS Unit 1, while also operating Unit 2 on behalf of its owner Square Butte Electric Cooperative, which is owned by the same 11 distribution member cooperatives that own Minnkota.

Minnkota's generation portfolio also includes energy purchased from three North Dakota wind

farms and hydroelectricity purchased from the Garrison Dam in central North Dakota. Minnkota operates and maintains a robust set of electric transmission infrastructure, including more than 3,350 miles of transmission line and 260 substations.

As the project developer, Minnkota is coordinating all aspects of the project development and has dedicated staff in place for project management, engineering & design, environmental/permitting, legal, and financing. As the operator of MRYS, Minnkota has unique knowledge that is necessary for the integration of the CO<sub>2</sub> capture plant. Minnkota also has more than 50 years of experience in coal-fired generation and the use of lignite fuel and its unique characteristics. Minnkota has hosted and managed several major construction projects at MRYS, with the most recent being \$425 million in environmental upgrades completed in 2007-2011 (described in more detail below).

In addition to construction projects at MRYS, Minnkota's Power Delivery division manages a portfolio of construction and maintenance projects ranging from \$35-50 million annually. The capital budget from 2023-2025 totals \$100 million with approximately half of that being associated with 69 kV transmission line projects. The remaining amount was used on distribution substation upgrades and maintenance, high voltage substation/line work and telecommunication and demand response system upgrades. Projects are scoped and scheduled in-house and utilize both in-house and contracted labor. One of the largest transmission projects in Minnkota's history, the \$350 million Center to Grand Forks 345 kV line, was completed in 2014 (described in more detail below).

### **Experience in the Fossil Sector**

Prior to describing two specific examples that demonstrate Minnkota's experience on similar

large construction projects, this section will first describe Minnkota's significant experience in the fossil sector.

Minnkota's Joint System has interests in three coal units, which represent approximately 55% of the Minnkota Joint System's generation capacity and 67% of the energy production. The three coal units are all located in North Dakota and fire North Dakota lignite coal:

- MRYS, Unit 1: Owned and operated by Minnkota, Unit 1 has nominal rating of 250 MW<sub>net</sub> and was placed in service in 1970. It is a single wall cyclone-fired unit that is equipped with the following controls: advanced separated over-fire air (SOFA) and selective non-catalytic reduction (SNCR) for nitrogen oxide (NO<sub>x</sub>) control, wet lime flue gas desulfurization (WFGD) scrubber for sulfur dioxide (SO<sub>2</sub>) control, an electrostatic precipitator (ESP) for particulate matter (PM) control, and a halide and post-combustion activated carbon injection for mercury control.
- MRYS, Unit 2: Owned by Square Butte and operated by Minnkota, Unit 2 has a nominal rating of 455 MW<sub>net</sub> and was placed in service in 1977. It is an opposed wall cyclone-fired unit that is equipped with the following controls: SOFA and SNCR for NO<sub>x</sub> control, WFGD for SO<sub>2</sub> control, ESP for PM control, and halide and post combustion activated carbon injection for mercury control.
- Coyote Station: NMPA owns 30% of Coyote and Minnkota is the operating agent for NMPA (Otter Tail Power operates Coyote). Coyote is a single unit, with a nominal rating of 427 MW and was placed in service in 1981. Coyote has a cyclone-fired boiler and is equipped with the following controls: SOFA for NO<sub>x</sub> control, dry flue gas desulfurization and fabric filter baghouse for SO<sub>2</sub> and PM control, and uses activated carbon injection for mercury control.

Minnkota continues to pursue and foster fossil energy technology, as evidenced by Minnkota's current and past involvement in cost share and engineering support for a number of DOE-funded research projects, including: 1) demonstration of multi-gamma based sensor technology for as-fired coal property measurement (DE-FE00031750), 2) mitigation of aerosol impacts on ash deposition and emissions from coal combustion (DE-FE00031756), 3) rare earth element extraction and concentration at pilot-scale from North Dakota coal-related feedstocks (DE-FE00031835), 4) novel concepts of the utilization of carbon dioxide from utility and industrial sources (DE-FE00031916), 5) energy storage for fossil power generation. Minnkota and EERC also previously completed a FEED study for Project Tundra with Fluor (DE-FE0031845) and a CarbonSAFE project for their storage complex (DE-FE0031889) and 6) recovery and refining of rare earth elements for lignite mine wastes (DE-FE0002618). This demonstrated, strong commitment to advancing fossil energy technology, combined with more than 70 years of experience operating and maintaining fossil fuel conversion plants, positions Minnkota well to execute on Project Tundra.

## **MRYS Environmental Upgrades**

### *Background:*

From 2007 to 2011, approximately \$425 million was invested in MRYS to install a series of air quality control system upgrades on each of the two units to modernize the facility and ensure compliance with environmental regulations. New controls and associated infrastructure were installed for SO<sub>2</sub> and NO<sub>x</sub>, with each of the major sub-projects for both units further described below.

The Unit 1 projects consisted of the following five major components:

1. Electrical upgrade of the unit (\$51 million) – Construction of the Unit 1 electrical upgrades were necessary to provide fault protection of the existing aging electrical system, and to provide capacity for load additions from the air quality control upgrades. The project included new Unit 1 auxiliary transformers; a replacement generator breaker; an electrical building to house medium and low voltage switchgear, motor control centers and distributed control system equipment; isolated phase bus modifications, a new backup diesel generator, a fuel handling electrical upgrade and substation, and duct banks.
2. Installation of a new WFGD scrubber (\$113 million) – Construction of a single module wet lime open-spray SO<sub>2</sub> scrubber. The scope included connecting ductwork and structural steel from the boiler exit to the refurbished chimney, two replacement induced-draft fans, all associated foundations, dampers and control devices, buildings, electrical, HVAC and other utility services, and the distributed control system.
3. Upgrade of the former Unit 2 dry chimney to a wet chimney for Unit 1's use (\$12 million) – Construction to retrofit the 564-foot “dry” chimney to a chimney suitable for wet service with the new wet scrubber. The chimney was wallpapered by installing 316L stainless over the existing mild steel and Corten metals of the dry chimney.
4. Installation of over-fire air and selective non-catalytic reduction systems on the boiler (\$16 million) – Construction included installation of a complete separated over-fire air (SOFA) system and selective non-catalytic reduction system (SNCR) for NO<sub>x</sub> control on the Unit 1 boiler. The SOFA system components included SOFA piping, nozzles, dampers, control drives, as well as significant modifications to the existing cyclone boiler lignite drying system. The SNCR system involved installation of systems to support urea

injection in multiple zones in the boiler. Supporting systems included metering and dilution water modules, storage tanks and supporting systems, and expanding the plant's water treatment system.

5. Installation of a joint new lime reagent preparation system to serve Unit 1 and Unit 2 (\$42 million) – Construction to install two new vertical ball mill slakers and associated pumps, tanks, and distribution systems. The project included two bolted, 3,000-ton lime storage silos.

The Unit 2 projects consisted of the following four major components:

1. Electrical upgrade of the unit (\$76 million) – Construction of the Unit 2 electrical upgrades were necessary to provide fault protection of the existing aging electrical system, and to provide capacity for load additions from the air pollution control upgrades. The project included new Unit 2 auxiliary transformers; a replacement generator breaker; an electrical building to house medium and low voltage switchgear, motor control centers and distributed control system equipment; isolated phase bus modifications, a new backup diesel generator, a fuel handling electrical upgrade and substation, and duct banks.
2. Upgrade of the existing WFGD scrubber on Unit 2 (\$2 million) – Included assessment for duty of two existing open spray tower absorbers, and installation of minor efficiency improvements, replacement demister panels, and replacement of the outlet ducts from the modules to the new chimney.
3. Installation of new wet chimney (\$67 million) – Construction included installation of a 6,425 cubic yard continuous-pour concrete slab-on-grade chimney foundation, and a 550-foot concrete chimney with fiberglass-reinforced plastic flue gas liner.

4. Installation of separated over-fire air (SOFA) and selective non-catalytic reduction systems on the boiler (\$18 million) – Construction included installation of a complete SOFA system and SNCR system for NO<sub>x</sub> control on the Unit 2 boiler. The SOFA system components included SOFA piping, nozzles, dampers, control drives, as well as significant modifications to the existing cyclone boiler lignite drying system. The SNCR system involved installation of systems to support urea injection in multiple zones in the boiler. Supporting systems included metering and dilution water modules, storage tanks and supporting systems, and expanding the plant’s water treatment system.

*Project Management:*

Minnkota and the project engineering consultant Burns & McDonnell evaluated options to pursue these projects on an EPC basis or on a “multi-contract” basis. Minnkota selected the multi-contract approach, and utilized plant project managers and Minnkota’s procurement department to issue all contracts related to the projects. Burns & McDonnell provided project schedules, design, plans and specifications, bidding assistance, and review of vendor submittals. Burns & McDonnell also provided construction observation, however overall construction management was Minnkota’s responsibility. Minnkota did not add personnel to complete the projects.

*Operation and Maintenance:*

As the operator of both Units 1 and 2, Minnkota is responsible for the operation and maintenance of the facilities’ equipment/infrastructure. With the completion of the final work in 2011, the projects were all in service. The projects have all been in service for at least 12 years and have



performed as expected, while additional efficiencies have been gained through operating and maintenance experience. Maintenance is performed using both in-house and contracted labor.

## **Center to Grand Forks 345 kV Transmission Line**

### *Background:*

In 2009, it was determined that Minnkota would construct a \$350 million, 250-mile-long 345 kilovolt (kV) transmission line in North Dakota between the Center 345 kV Substation (northeast of the Milton R. Young Generation Station, near Center, North Dakota) and the Prairie Substation (west of Grand Forks, North Dakota). The Center to Grand Forks 345 kV Transmission Line Project (CGF Project) was constructed to deliver existing baseload generation to Minnkota's cooperative members in North Dakota and Minnesota.

This project helped provide much needed transmission capacity in North Dakota as new resources are brought on to the grid.

The CGF Project consisted of the following six major components:

1. 345 kV High Voltage Transmission Line – Construction of 250 miles of a new, high-voltage transmission line. The line is constructed with single-pole steel structures approximately 150-feet-high and placed approximately 1,000-feet apart. The typical right-of-way (ROW) is 150-feet-wide. Conductor is 959.6 kcmil Suwanee trapezoidal wire (TW) type aluminum conductor steel reinforced (ACSR) cables and two shield wires – one a fiber-optic static line and the other an extra high strength (EHS) steel cable.
2. Center 345 kV Substation Upgrades – Installation of 345 kV circuit breakers, 345 kV dead-end structures, a new 345/230 kV transformer and associated bus work, new 345 kV

switches and associated foundations, steel structures, and control panels. A line reactor was also added to the north end of the substation.

3. Additional 230 kV Tie Line – Construction of a 1,500-foot-long 230 kV tie line paralleling the existing tie line on Minnkota-owned property to complete a transmission-to-transmission interconnection with the Square Butte 230 kV Substation.
4. Square Butte 230 kV Substation Upgrades – Installation of 230 kV circuit breakers and line terminal equipment to the new 345 kV interconnect.
5. Prairie 230/345 kV Substation Upgrades – Installation of new 345 kV circuit breakers, 345 kV dead-end structures, two new 345/230 kV transformers and associated bus work, new 345 kV switches and associated foundations, steel structures, and control panels. Addition of 230 kV circuit breakers to accommodate interconnecting with the existing 230 kV ring bus.
6. Fiber Optic Regeneration Stations – Construction of four fiber optic regeneration stations along the transmission line route to re-amplify the protection and control signals carried in the optical ground wire (OPGW). Each station has a small control building to house the electronic equipment in a fenced-in area.

Minnkota was able to coordinate all federal, state and local permitting and environmental requirements and met all applicable guidelines. The project schedule required Minnkota to parallel the design and the route permitting to meet the in-service date. This required engineering, procurement and environmental work to be done simultaneously, something that is typically not done. The extremely short schedule (four years) required a concerted effort in multiple areas, including these primary phases:

- Route application and permitting – This process included determining the 250-mile transmission line route and conducting multiple public hearings across the 11 impacted counties in North Dakota.
- Complete Environmental Assessment (EA) – this included an alternative evaluation study (AES), a macro-corridor study (MCS), a biological assessment (BA), and a Class III Intensive Archaeological Resources Inventory in compliance with Section 106.
- Equipment procurement, manufacture and delivery – To meet the in-service date, Minnkota ordered long lead-time items early in the process to allow for delivery and construction on schedule. Due to the expedited nature of the project, this was done before the permitting process was completed.
- Construction – this included simultaneous work on 250 miles of line, two high voltage substation rebuilds, modifications to an existing substation and construction of four repeater stations.

*Project Management:*

Minnkota supported the Project with a project manager (PM) to coordinate all project activities, schedule and budget. Minnkota also provided all of the material procurement from internal resources. Additional contracted labor was required for the following: **1)** line and substation design, **2)** construction management, **3)** environmental and permitting, and **4)** right of way easements. The construction of the 250-mile line was done by contracted labor in addition to the substation civil work. However, Minnkota crews did a majority of the electrical work within the substations and in-house support and guidance was provided by environmental, engineering, operations, legal, finance and various other groups.

### *Operation and Maintenance:*

The CGF Project was energized in 2014 and at that time doubled Minnkota's existing 345 kV transmission line assets. The Project is part of the bulk electric system (BES) and therefore meets specified North American Electric Reliability Corporation (NERC) requirements. All 345 kV transmission is included in the high voltage maintenance program and is patrolled annually by helicopter, fixed wing aircraft and ground patrol. Regular vegetation management is conducted and maintenance is done as needed.

The expansion of both the Center and Prairie 345 kV substations added additional assets to the electrical operation's maintenance program and are included in the standard rotation for equipment inspections. Both sites are included in the BES and meet all NERC requirements.

The addition of four repeater stations expanded the telecommunication assets and are regularly inspected and maintained.

Minnkota conducted the design and construction of the Project without adding any additional personnel. Contracted labor was used during construction but ongoing maintenance is done by Minnkota personnel.

### **Financing of the MRYS Environmental Upgrades and CGF Project**

Minnkota's portion of the \$425 million Environmental Upgrade Projects and the \$350 million CGF Project were funded by loans from the Rural Utilities Service (RUS), an operating unit of the United States Department of Agriculture, via RUS Guarantees made to the Federal Financing Bank (FFB). As a rural electric cooperative, Minnkota has had tremendous success utilizing the low interest, long amortization loans offered through the RUS. Minnkota's utilization of RUS

financing coincides with the preferred industry practice of financing long-term assets with appropriately amortized funds, ensuring intergenerational equity is achieved on large capital projects. Minnkota secures outstanding debt under an Indenture, with U.S. Bank acting as Trustee. The Indenture secures certain obligations of Minnkota equally and ratably by a first priority lien on substantially all of Minnkota's tangible assets and certain of its intangible assets, whether now owned or acquired in the future. Square Butte's portion of the \$425 million Environmental Upgrade Projects was financed half through RUS and half through CoBank, ACB, and similarly secured using Square Butte's Indenture.

### **Principal Participants Capabilities and Qualifications**

This subsection of the Application will focus on and describe the capabilities of the team Minnkota has put together to develop and bring the proposed project to commercial operation. Minnkota has a fully integrated team in place including all of the technical, legal and financial pieces necessary. The following sections highlight the key team members, their role(s) on the project, and a description of the capabilities that each member brings to the proposed project.

### **Technology Provider – See Confidential Appendix A**

### **Owners Engineer**

#### **A-6 Owners Engineer**

### **Sargent & Lundy**

As Owner's Engineer S&L is providing engineering and technical support to Minnkota in managing the technology providers portion of the project scope as well as engineering and execution planning for Minnkota's portion of the balance of plant which will be construction and commissioned by Minnkota using various contractors.

S&L is one of the longest-standing and most experienced full-service architect engineering firms in the world. Founded in 1891, the firm is a global leader in power and energy with expertise in grid modernization, renewable energy, energy storage, nuclear power, and fossil-fueled power plants. S&L has been involved in numerous first-of-a-kind projects and concepts throughout our more than 130-year history. Our identity is rooted in a culture of innovation and quality. We have been at the forefront of new design throughout this time, often on initiatives for new technologies or concepts within the power generation markets.

S&L has extensive experience conducting technical evaluations for CO<sub>2</sub> capture projects over the last decade, including feasibility, Pre-FEED, and FEED studies for clients which included preliminary system engineering, project layout, preliminary design, and cost estimates. S&L has completed 45 projects with an additional 25 active projects currently on-going, for nearly 40 clients involving 15+ technologies since 2007.

Among the most notable projects for S&L was the Petra Nova Carbon Capture Project, which was awarded the Best Project of Merit award from Engineering News Record (ENR). S&L's work on the Petra Nova project included multiple FEED studies, Owner's Engineer services during project implementation, and detailed design of the 240 MW equivalent (MWe) slipstream carbon capture unit onto NRG's W.A. Parish Unit 8. The Owner's Engineering services included both design oversight and the detailed design of critical systems that tied into the host site, such as the flue gas ductwork supply and wastewater treatment.

**Construction Management – See Confidential Appendix A**

**Constructor – See Confidential Appendix A**

### **David Greeson Consulting (Proven Project Development Group)<sup>3</sup>**

David Greeson is a consultant to the carbon capture and power generation industries. He was the developer (from inception through commissioning) of the \$1 billion Petra Nova CO<sub>2</sub> Capture and Enhanced Oil Recovery Project in Texas and is currently working with multiple clients in various stages of development of CCUS projects. Mr. Greeson has been working with Minnkota for about the last three years, focusing on the business development and financing aspects of the proposed project.

### **Hunt International Energy Services (HIES)**

Marion Cole is a principal with HIES, an independent energy industry consulting firm established in 1999. Mr. Cole has 40 years of experience in power systems engineering, operations and consulting, with expertise focused on power and pipeline sectors with both U.S. and international clients. Mr. Cole was a key member of the engineering team that developed the Petra Nova project and he supported both the CO<sub>2</sub> capture plant and the 81-mile CO<sub>2</sub> pipeline that transported the captured CO<sub>2</sub> to the enhanced oil recovery fields. Mr. Cole is a consultant to Minnkota focused on the engineering, design and construction aspects of the CO<sub>2</sub> capture plant and the CO<sub>2</sub> pipeline and he is actively engaged currently on both FEED studies.

### **Global Structured Finance (GSF)<sup>4</sup>**

Minnkota has retained the advisory services of GSF to support the full capital stack raise for the proposed project. GSF, founded in 2005, is a structured finance advisor, providing strategic advice and innovative financing solutions to meet its clients' capital raising, investment, tax and

---

<sup>3</sup> <https://www.davidgreeson.com/>

<sup>4</sup> <https://www.gsfadvisors.com/>

accounting needs. More specifically, GSF is engaged in providing advisory services to clients in connection with the financing of assets with significant tax benefits (principally tax credits, as well as depreciation and interests deductions).

GSF also provides placement services and has closed transactions and maintains relationships with all major tax-motivated investors.

The GSF Advisors energy team recently left a major European Bank where they conducted business as Capstar Partners and were responsible for tax equity advisory and investments. Capstar Partners was an independent firm founded in 1990 providing investment banking services to clients in the tax advantaged asset finance market. It was acquired by a European bank in 2001. The team is led by Phil Mintun, who was the founder and head of the Capstar renewable energy tax equity team, and François-Xavier (“FiX”) Terrasse, who was responsible for the bank’s tax equity investments and led the most highly structured transactions.

Since 2005, the team has raised \$20.7 billion from 19 tax equity investors to finance over 25GW of renewable energy facilities – 114 wind farms, 37 utility scale solar plants, 4 geothermal facilities, 4 distributed generation solar portfolio as well as 1 fuel cell portfolio and 1 biomass plant. In addition, the team has been active advising clients on carbon capture and sequestration projects over the past several years.

### **Holland & Knight LLP**

Holland & Knight has been retained as Project Counsel and has significant experience in energy and infrastructure development and financings.



Holland & Knight's Energy & Natural Resources Industry Sector Group brings together a cross-practice and experienced group of more than 225 lawyers and professionals, in 34 offices, to represent and advise a wide array of stakeholders across the energy and natural resources value chain. Furthermore, more than 50% of the firm's energy team members are diverse.

The firm's attorneys have represented energy industry clients for more than 120 years, in all 50 states as well as more than 80 countries around the globe. As a result, Holland & Knight not only provides integrated service through the collaboration of attorneys across a broad range of practice areas, but these attorneys also truly understand the industry and have a pulse on recent market trends as well as insight into how to best navigate an increasingly complex regulatory environment.

Holland & Knight is ranked among the top global firms for Energy & Natural Resources by *Chambers Global 2023* as well as among the top U.S. firms for Energy: Renewable / Alternative Power by *The Legal 500 United States 2022*.

The firm's history of excellence in serving the regulatory, compliance and policy needs of clients in addition to commercial, financial and operational experience uniquely positions their team to provide legal counsel on increasingly complex transactions. This well-established experience combined with a team of well-regarded, high-profile litigators, makes Holland & Knight's energy practice well positioned to provide the full range of legal services to Project Tundra.

For more than four decades, Holland & Knight has been privileged to provide services to the electric cooperative industry in the U.S. They have the leading electric cooperative practice in the country, a key component of which is assisting their clients with the development of major projects and obtaining necessary financing. Their lawyers understand the electric cooperative

business, and the breadth and depth of their practice experience brings extra value to electric cooperative clients such as Minnkota.

The firm's lawyers have extensive experience guiding clients through all phases of EPC contracts, each based on individual client and client industry needs offering guidance from design concept, property acquisition and contract negotiations to risk management, contract compliance, claims management, alternative dispute resolution and litigation. Holland & Knight is experienced at resolving disputes arising from EPC and design/build agreements (both through litigation, as well as via arbitration, mediation, negotiation and other forms of alternative dispute resolution).

Holland & Knight's experience in cooperative finance includes structuring and negotiating an array of financing transactions, including traditional interim (construction) and permanent debt financing, tax exempt bond financing, non- and limited-recourse project financing, leveraged and synthetic leases and other structured vehicles. Both inside and outside the cooperative industry, Holland & Knight represents developers, utilities and their subsidiaries, investors and financial institutions in the sourcing and negotiation of senior, mezzanine and subordinated project loans, corporate credit financings, domestic and international private placements, Rule 144A offerings, public bond offerings, lease financings, construction and term loan financings, bridge financing and operating lines of credit.

Holland & Knight lawyers are well-versed and able to handle all relevant types of financing documentation, project documentation and the coordination of the two (negotiating and drafting project documentation to be financeable). The firm's broad experience includes the Department of Energy and Department of Agriculture federal loan guarantees and various tax and tax-equity

advantaged structures involving monetizing tax credits, cash grants, production tax credits and clean renewable energy bonds (CREBs).

Additionally, Holland & Knight has significant experience representing cooperatives, alternative energy project developers, cash equity sponsors and tax equity investors in tax equity transactions including partnership flips, sale-leasebacks and inverted leases involving wind, solar, hydropower, geothermal, biomass and landfill gas facilities. Given the significant tax benefits associated with alternative energy projects, their team ensures compliance with the requirements to claim federal tax credits (including production and investment tax credits), as well as any available state tax incentives. Their representation of clients in IRS controversies at the IRS administrative level and in trial and appellate level courts provides great insight in properly structuring a transaction to avoid or withstand IRS scrutiny.

## MANAGEMENT

*A description of **how** the applicant will manage and oversee the project to ensure it is being carried out on schedule and in a manner that best ensures its objectives will be met, **and a description of the evaluation points to be used** during the course of the project.*

Since the proposed project is currently in development, this section will provide the key staff and summary of roles for Minnkota's development of the proposed project. Once the project reaches the construction phase, this list of key staff will change. Further, each of the key staff listed below are full-time Minnkota employees. Information about Minnkota's external resources (consultants, engineering, permitting, legal, financing) that have been engaged to develop the proposed project can be viewed in the previous section.

Key Minnkota staff are considered the Project Manager and the component leads (Engineering, Geologic Storage, Legal, Financing) and are listed below. The key staff are supported by the CEO, CFO and General Counsel, who are also listed below.

- Robert “Mac” N. McLennan, President & CEO: Overall project oversight and direction.
- Kay L. Schraeder, Vice President & CFO: Overall financial oversight and direction.
- Gerad C. Paul, Vice President & General Counsel: Overall legal oversight and direction.
- Craig Bleth, Vice President of Project Development: Project Manager
- Shannon R. Mikula, Special Projects Counsel: Geologic Storage Facility Lead, Environmental Manager, and In-house Project Counsel
- Andrew C. Sorbo, Vice President – Strategic Initiatives: Commercial & Financing Lead

In addition to the above-named key staff, Minnkota has dedicated (full or in part) several additional staff to this project development. Further, as detailed above, Minnkota’s key staff and their expertise are strongly augmented by the external experts retained to bring this project to commercial operation.

## **TIMETABLE**

*Please provide a project schedule setting forth the starting and completion dates, dates for completing major project tasks/activities, and proposed dates upon which the interim reports will be submitted.*

Because of the first-of-a-kind at this scale and in this application nature of this project, Minnkota is expecting to need all permits and other regulatory approvals completed prior to financial close. To meet the target schedule of start of construction by the end of first Quarter of 2024, Minnkota has submitted permit applications on a schedule to have all approvals by the end of 2023. The storage facility permits were issued in January 21, 2022, NDIC Order No. 31583-31588. The air

permit PTC application was filed in May 2023, which should enable final approval by the end of 2023.

## BUDGET

*Please use the table below to provide an **itemized list** of the project’s capital costs; direct operating costs, including salaries; and indirect costs; and an explanation of which of these costs will be supported by the financial assistance and in what amount. The budget should identify all other committed and prospective funding sources and the amount of funding from each source. **Please feel free to add columns and rows as needed.** Higher priority will be given to projects with a high degree of matching private industry investment.*

Minnkota is negotiating a capital structure that will involve equity contributions from Minnkota and its partner(s) to fund the construction of the CO<sub>2</sub> capture plant (“CaptureCo”) and the CO<sub>2</sub> pipeline and storage facility (“StorageCo”). In this structure the 45Q tax credits and NOLs (the NOLs and tax credits are referred to as “tax attributes”) will roll up to the joint venture where Minnkota and its partner will divide the tax credits and tax attributes. It is expected that Minnkota’s partner will monetize the tax attributes and uses the proceeds to pay for operating costs. Under this structure, the project would need \$1.40 billion in capital and that would come from a DOE grant and sponsor equity from Minnkota and its partner(s), and a CSEA loan.

As noted above, the FEED study will produce a final detailed engineering project price that will be reflected in a fixed-firm Engineering, Procurement and Construction (EPC) contract offer.

CapEx costs for the CO<sub>2</sub> geologic storage facility (StorageCo) will consist of a combination of fixed-firm and reimbursable contracts since pricing for drilling activities is not generally fixed.

Preliminary quotes for these services are included in the \$1.40 billion estimated total project cost estimate. See additional detail in the Confidential Appendix A.

**Preliminary Sources and Uses during construction and at COD:** Confidential – Appendix A

## **PATENTS/RIGHTS TO TECHNICAL DATA**

*Any patents or rights that the applicant wishes to reserve must be identified in the application. If this does not apply to your proposal, please note that below.*

**See Confidential Appendix A for listed Patent rights.**

## **STATE PROGRAMS AND INCENTIVES**

*Any programs or incentives from the State that the applicant has participated in within the last five years should be listed below, along with the timeframe and value.*

Project Tundra, through Minnkota as project sponsor, received great support from the North Dakota Lignite Research Council (LRC). Minnkota was awarded in 2018 grant funds for use on the feasibility engineering and design as well as the front-end engineering and design (FEED) for the capture technology retrofit to lignite coal-fired generating assets and for use on a FEED of a pipeline transport for captured CO<sub>2</sub> and EOR surface facility system for the legacy oilfield west of the Milton R. Young Station. The LRC grant funds were instrumental in the early and intermediary stage of research and engineering of the project to determine the applicability and feasibility of the technology design on lignite fuel gas. Additionally, Minnkota leveraged these LRC grant funds on a 1:4 ratio securing federal funds from the Department of Energy National Energy Technology Laboratory, CarbonSAFE and Office of Fossil Energy. Lastly, in February 2022 the NDIC approved an LRC grant to fund on a 50-50 basis a portion of the final engineering work needed to finance the project and move into the construction phase.



Lignite Energy Council  
PO Box 2277  
Bismarck, ND 58502  
Tel. (701) 258-7117

May 19, 2023

Mr. Andrew Sorbo  
Minnkota Power Cooperative  
5301 32<sup>nd</sup> Ave S.  
Grand Forks, ND 58201

Subject: Minnkota Power Cooperative Proposal for Project Tundra

This letter is to signify the Lignite Energy Council's support of Minnkota Power Cooperative in its pursuit of funding from the Clean Sustainable Energy Authority (CSEA) for Project Tundra, which will demonstrate post-combustion carbon capture (PCCC) and carbon dioxide storage in North Dakota. This project is a critical piece in the progression toward Governor Burgum's goal of carbon neutrality by 2030 by capturing up to 4 million metric tons of carbon dioxide annually, making it the largest single-train PCCC in the world. Commitment from the CSEA through a low-interest loan will help demonstrate that Project Tundra is worthy of consideration by other investors.

Minnkota Power Cooperative's Project Tundra initiative will build the PCCC capture facility at the existing Milton R. Young Station, a lignite-based power plant in North Dakota. The captured CO<sub>2</sub> will be safely and permanently stored in geologic formations up to 9,000 feet directly underground of the Milton R. Young Station. Participants in the project in addition to sponsor and owner Minnkota Power Cooperative include anticipated funding through the U.S. Department of Energy and overall construction management from Sargent & Lundy on behalf of the project owners.

The Milton R. Young Station is a critically important dispatchable energy resource that also sustains high-paying jobs and essential positive economic impacts for local communities and the surrounding region. The generation resource has dispatched more than a 90% average running plant capacity factor over the past five years boasting cost predictability and performing reliably despite market volatility. Project Tundra will help preserve this power resource.

The Lignite Energy Council believes Project Tundra meets the Clean Sustainable Energy Authority's mission to deploy technological advancements through partnerships and provide financial support for the large-scale development and commercialization of projects, processes, activities, and technologies that reduce environmental impacts and increase the sustainability of energy production and delivery.

Sincerely,  
Jason Bohrer

A handwritten signature in black ink that reads "Jason Bohrer" with a stylized flourish at the end.

President & CEO  
Lignite Energy Council

Submitted by: Newlight Technologies, Inc.  
 Project Duration: 35 months  
 Total Project Costs: \$446,000,000  
 Request for: \$150,000,000 loan

**Summary of Project:** This project supports the construction of a facility in North Dakota that will manufacture AirCarbon, a plastics-alternative that is carbon-negative and biodegradable.

### Technical Review Results

Overall Technically Sound (195/315)		
Good	1	
Fair		
Questionable	1	

### BND Economic Feasibility Recommendation

Overall Economic Feasibility	
Yes	X
No	

### Technical Committee Scores

	Score (Out of 50)
Charlie Gorecki	43
Josh Teigen	45
Dave Glatt	41
Lynn Helms	42 with conditions
Justin Kringstad	40
Rachel Retterath	43
Todd Steinwand	40
John Weeda	49

Average: 43

**Recommendation: 8-0 Consider funding with condition that only Phase I of the proposal is funded**



# TECHNICAL REVIEWERS' RATING SUMMARY

## C-04-E

Project Phoenix

Submitted By: Newlight Technologies, Inc.

Date of Application: May 2023

**Request for \$150,000,000 Loan**

**Total Project Costs \$446,000,000**

Rating Category	Weighting Factor	Technical Reviewer		Average Weighted Score
		E1 Rating	E2 Rating	
1. Objectives	3	3	4	10.5
2. Impact	9	3	3	27
3. Methodology	9	2	4	27
4. Facilities	3	2	4	9
5. Budget	9	2	4	27
6. Partnerships	9	2	4	27
7. Awareness	3	2	3	7.5
8. Contribution	6	3	4	21
9. Project Management	6	2	4	18
10. Background	6	3	4	21
315		150	240	195

**OVERALL TECHNICALLY SOUND**

GOOD (IF > 214)	<input type="checkbox"/>	<input checked="" type="checkbox"/>
FAIR (200-213)	<input type="checkbox"/>	<input type="checkbox"/>
QUESTIONABLE (IF < 200)	<input checked="" type="checkbox"/>	<input type="checkbox"/>

Mandatory Requirements	E1		E2	
	Yes	No	Yes	No
Diversification Delivery:				
Project enhances the production of clean sustainable energy, to make the State a world leader in the production of clean sustainable energy, and/or to diversify and grow the State's economy.		✓	✓	
Commercialization or Development/Expansion:				
Concept will lead to the <b>large-scale development and commercialization</b> of projects, processes, activities, and technologies that reduce environmental impacts and/or increase sustainability of energy production and delivery.	✓		✓	

In State Requirement:	Yes	No	Yes	No
The funds distributed from the financial assistance are to be applied to support in-state activities and must have other sources of financial support.		✓	✓	

- The objectives or goals of the proposed project with respect to clarity and consistency with Clean Sustainable Clean Energy Authority goals of projects, processes, activities, and technologies that reduce environmental impacts and increase sustainability of energy production and delivery are: 1 – very unclear; 2 – unclear; 3 – clear; 4 – very clear; or 5 – exceptionally clear.**

**Reviewer E1 (Rating 3)**

The objectives of the proposed project are clear and consistent with those established by the Clean Sustainable Energy Authority (CSEA).

**Reviewer E2 (Rating 4)**

Projects' goal is to build at Marley Crossing, in Williams County, a Plant that will produce PHB, a material that will displace plastics and it's detrimental effect on the climate.

- The objectives will make a difference in the near term to the state's economy: 1 – no impact; 2 – small impact; 3 – likely impact; 4 – most likely impact; or 5 – significant impact.**

**Reviewer E1 (Rating 3)**

The proposed project has the potential to have an impact on the state's economy. Due to the lack of a firm commitment to the ND based facility I have rated it as 3. I'm not convinced that the time line suggested is achievable and therefore near term impacts are not certain.

**Reviewer E2 (Rating 3)**

The Gantt Chart provided and the writeup confirms a 35-month schedule so a dominant near term economic benefit may not be realized but long term could be significant.

- The quality and clarity of the methodology in the proposal is: 1 – well below average; 2 – below average; 3 – average; 4 – above average; or 5 – well above average.**

**Reviewer E1 (Rating 2)**

This reviewer has a fundamental problem with the methodology noted in that the state has already funded a FEED study for the ND facility and now the group is requesting funding for detailed engineering and construction. I believe that this request is premature and should wait until those results are available to allow the state that information prior to a decision on funding a loan request for the phase including construction of a commercial facility.

**Reviewer E2 (Rating 4)**

Method provided shows a "milestone- based gate" approach. A small plant is already producing a product with the technology. The plans provided show proposed plants in Ohio and Williams County, ND. If the evaluation at Gate 1 shows a fatal climate or procurement flaw with a ND location, Williams County may not prove a good choice.

- 4. The facilities and equipment available and to be purchased for the proposed pilot or commercialization strategy is: 1 – very inadequate; 2 – inadequate; 3 – adequate; 4 – notably good; or 5 – exceptionally good.**

**Reviewer E1 (Rating 2)**

The proposal lists a commercial facility to produce AirCarbon as the facility to be funded with the requested loan. There is no information on the size of the facility, its impact on the current market or the estimated growth rate for the product. No data on the range of input prices that would make it commercially viable was given. These shortcomings in the information provided make it impossible to comment positively on the viability of the proposed facility.

**Reviewer E2 (Rating 4)**

A plan is in place to utilize local suppliers and contractors. Delivery schedules and climate may impact schedule.

- 5. The proposed budget is comprehensive and sufficient relative to the outlined work and the timetable: 1 – not sufficient; 2 – possibly sufficient; 3 – likely sufficient; 4 – most likely sufficient; or 5 – certainly sufficient.**

**Reviewer E1 (Rating 2)**

The proposal has very limited information for the proposed activity. Certainly not enough to make a judgement on the expected success of this venture. A critical issue is identification of the source of the \$291,000,000 offered as cost share by Newlight Technologies? I assume that this will require financing and there is no discussion of the source for these funds. Also the budget noted includes the funding already received for the state as well as the cost share offered up for the already funded FEED activity. It's not clear if that funding is not sufficient to complete the initially funded work and the requested dollars will be used to complete what should have been already funded. This all related to my earlier comment that I believe the FEED study already funded should be completed before the additional funding request is evaluated.

**Reviewer E2 (Rating 4)**

NDIC is being asked for \$150Mm of a \$446MM project to engineer, design, construct, commission, and startup a Plant this size. \$292MM is the applicants share which shows their confidence in their technology. ND's \$150MM will be utilized during the initial feed (Gate 1), which will prove or disprove a ND location.

- 6. The appropriate strategic partnerships are in place for short and long term plans to be successful: 1 – very limited; 2 – limited; 3 – adequate; 4 – better than average; or 5 – exceptional.**

**Reviewer E1 (Rating 2)**

The proposal as submitted alludes to a number of possible partnerships. The only one that is defined is with Burns & McDonnell for work on the FEED study. This has not been finalized and is based on the earlier funding. I would like to see clearly that relationships with key organization especially those ND group have been established as spending funds in ND is a key criteria for evaluating projects submitted in this program.

**Reviewer E2 (Rating 4)**

Newlight owns the technology and Burns & McDonnell is a reputable engineering and design group with many years of experience designing plants/retrofits for existing and new facilities.

- 7. The likelihood that the project approach (time & budget) will achieve its technical and market goals is: 1 – not achievable; 2 – possibly achievable; 3 – likely achievable; 4 – most likely achievable; or 5 – certainly achievable.**

**Reviewer E1 (Rating 2)**

The limited information provided on the budget and commercial facility makes impossible to say with any certainty that they will be successful in achieving the goals as stated in the proposal.

**Reviewer E2 (Rating 3)**

It's a bit difficult to predict the outcome of a proposed 35-month project of this magnitude. The engineering and design phases should parallel predictions however once the procurement and construction take place, many variables (climate/location, etc.) could affect the time and budget.

- 8. The scientific and/or technical contribution of the proposed work to specifically address Clean Sustainable Energy Authority goals of impacting technology used in North Dakota's energy industries will likely be: 1 – extremely small; 2 – small; 3 – significant; 4 – very significant; or 5 – extremely significant.**

**Reviewer E1 (Rating 3)**

The contribution of the proposed project toward meeting the goals of the CSEA could be significant. Unfortunately the provided information does not give this reviewer confidence that the resources will be there to achieve that goal in North Dakota.

**Reviewer E2 (Rating 4)**

Elimination of plastic or a major reduction thereof will have significant environmental impact. Utilizing CO<sub>2</sub> for the production and sequestration enhances that impact.

- 9. The project management plan, including budgeting projections, partner connections and well-defined milestone chart is: 1 – very inadequate; 2 – inadequate; 3 – adequate; 4 – notably good; or 5 – exceptionally good.**

**Reviewer E1 (Rating 2)**

The information presented is lacking in budget information and partner connections as noted in earlier comments. This reviewer would want to see go/no go decisions that involve the funding groups as a number of questions remain that will need to be addressed since there a lack of information provided in the submission.

**Reviewer E2 (Rating 4)**

The Gantt chart specifically calls out Milestone Gates as previously mentioned. The proposal specifically mentions responsibilities for the Project Management to pass all updates to members including NDIC.

**10. The background and experience of the project principals with regards to technical qualifications and competence is: 1 – very limited; 2 – limited; 3 – adequate; 4 – better than average; or 5 – exceptional.**

**Reviewer E1 (Rating 3)**

The lack of information as to exactly what the technology is makes it impossible to judge the background of the principals noted in this proposal. They do appear to have very good academic backgrounds and appear to have technical experience of value.

**Reviewer E2 (Rating 4)**

The technology has been proven to produce materials which have displaced plastics which, as previously stated, has huge impacts for the environment. ND should also realize additional high paying jobs and a smaller carbon footprint. Major replacement of plastics should result in a major economic benefit for the owners.

---

**Section C. Overall Comments and Recommendations:**

**Please comment in a general way about the merits and flaws of the proposed project and make a recommendation whether or not the project is technically sound.**

**Reviewer E1**

The proposed technology commercialization activity involves a technology that I believe has potential. If the proposers would complete the already funded FEED study and share that information as well as details on the technology involved and the source of their financial contribution I believe this development could be considered for additional funding through a loan. Based on what has been provided this reviewer would not recommend funding at this time.

**Reviewer E2**

Climate concerns and procurement/marketing distances may prove to be a restrictive issue. The applicants have proposed to supply 65.5% of the capital for the project. \$150MM of North Dakota money is also significant therefore if successful, should not North Dakota receive some added return on investment in a collaborative agreement?



# NEWLIGHT

May 19<sup>th</sup>, 2023

Newlight Technologies  
14382 Astronautics Lane  
Huntington Beach, CA 92647

**Re: Project titled "Project Phoenix: Manufacturing bio-degradable polymers using methane as a feedstock"**

NDIC & Clean Sustainable Energy Authority Program:

Newlight Technologies, Inc. is submitting this application for loan funds under the North Dakota Industrial Commission Clean Sustainable Energy Authority Program. This project supports the construction of a large scale AirCarbon PHB polymer production facility in North Dakota, and will help the state achieve its 2030 carbon neutrality goals.

Newlight Technologies utilizes greenhouse gas as the carbon feedstock to produce AirCarbon, a carbon-negative, naturally occurring, biodegradable biopolymer that can be used to replace traditional plastics. Newlight currently produces AirCarbon out of a demonstration scale facility in Huntington Beach, California, but is looking to expand production aggressively to meet demand. AirCarbon is currently being sold primarily in the foodware market as a replacement for straws, cutlery, and coated paper products that are traditionally made out of oil-based plastics.

Newlight Technologies is seeking funds to engineer and build a production facility in North Dakota. The project is estimated to cost \$446MM. When completed this business will:

1. create 80+ new green jobs
2. generate new local products and tax revenues for North Dakota
3. significantly help North Dakota reach its sustainability and carbon neutrality goals

We are requesting \$150,000,000 in support from the Clean Sustainable Energy Authority Program of the North Dakota Industrial Commission. In return, Newlight Technologies, Inc. commits to matching funds to complete the project.

If you have any questions or require additional information, please do not hesitate to contact Kenton Kimmel, [kk@newlight.com](mailto:kk@newlight.com)



Kenton Kimmel, CTO



Clean Sustainable Energy Authority  

---

North Dakota Industrial Commission

## Application

Project Title: Project Phoenix: Manufacturing bio-degradable polymers using methane as feedstock.

Applicant: Newlight Technologies, Inc.

Date of Application: May 19, 2023

Amount of Request

Grant: **\$ 0 USD**

Loan: **\$150 MM USD**

Total Amount of Proposed Project: **\$446 MM USD**

Duration of Project: **35 months from CSEA Approval**

Point of Contact (POC): Kenton Kimmel, Chief Technology Officer, Newlight Technologies

POC Telephone: (714) 556-4500

POC Email: [kk@newlight.com](mailto:kk@newlight.com)

POC Address: Newlight Technologies, Inc.

14382 Astronautics Lane

Huntington Beach, CA 92647

## TABLE OF CONTENTS

*Please use this table to fill in the correct corresponding page number.*

<b>Abstract</b>	<b>3</b>
<b>Project Description</b>	<b>5</b>
<b>Standards of Success</b>	<b>14</b>
<b>Background/Qualifications</b>	<b>15</b>
<b>Management</b>	<b>17</b>
<b>Timetable</b>	<b>18</b>
<b>Budget</b>	<b>19</b>
<b>Confidential Information</b>	<b>20</b>
<b>Patents/Rights to Technical Data</b>	<b>20</b>
<b>State Programs and Incentives</b>	<b>21</b>
<b>Loan/Loan Guarantee Application (if applicable)</b>	



## ABSTRACT

### Background:

Founded in 2003, Newlight is a nature-inspired biotechnology company based in California that is converting air and greenhouse gas into a biomaterial called AirCarbon®. Newlight's mission is to help end plastic pollution and climate change by replacing plastic with AirCarbon, creating global-scale economic and environmental value.

Newlight uses a technology that is found in ecosystems throughout the world, including in the ocean, wherein naturally-occurring microorganisms consume air and greenhouse gas, including methane and carbon dioxide, through fermentation to produce a muscle-like material inside of their cells called PHB. PHB is an energy storage material made in most living organisms, from marine microorganisms to the roots of plants, and can be melted into shapes as a replacement for plastic. Newlight is the first company to directly transform greenhouse gases into PHB, a biomaterial that the company calls AirCarbon, at commercial scale.

AirCarbon competes on performance with various grades of polypropylene, the second largest-volume plastic in the world. With a variety of potential industries to serve, Newlight's primary focus is on addressing ocean plastic pollution by displacing plastic in the foodware market, starting with straws, cutlery, and coated paper products. In addition to foodware, Newlight is also seeding expansion in automotive and fashion applications. Newlight launched its first commercial-scale AirCarbon production facility in 2020, and today Newlight's customers and partners include Shake Shack, Nike, Target, H&M, Ben & Jerry's, Sumitomo, US Foods, and Sysco, with millions of AirCarbon units delivered to consumers to date.

In this application, we are requesting financial support in the form of a \$150 million loan to support EPC related to a future plant in North Dakota.

We have completed two stage gates, FEL1 and FEL2. Newlight is poised to award FEL3/FEED contract to Burns & McDonnell after having competitively bid to ten recognized EPC firms. Newlight also received a CSEA grant in 2022 (\$4,185,625), this money will be used for FEED in addition to money awarded here.

### Objectives:

Newlight executed a feasibility /location study that was partially funded by the Renewable Energy Program/Industrial Council in 2021. This study, concluded in 2022 as Phase 1 of the overall project, showed that there is reason to believe that developing a large-scale industrial plant to produce AirCarbon in the state, while challenging, is very feasible, and several sites were considered. While Newlight has signed a contract to build a plant in Ohio, Newlight is still very interested in developing a facility at the Marley Crossing/Savage Services location near Trenton (like many of the projects under CSEA consideration).

However large the potential, currently Marley Crossing is undeveloped land, and to support an AirCarbon plant, gas, water, and power infrastructure and related suppliers need to be in place and fully

vetted. Mitigating the risks associated with the infrastructure build-out and the input costs associated with the site needs to work to meet shareholder targets. In addition, the climate of North Dakota will result in some special requirements related to climate and transporting equipment into the area. Solving these cost inputs, engineering and infrastructure issues is the primary objective of Phase II in this request.

The objectives are:

- Fund engineering, design, construction, commissioning and startup work for a plant in northwest North Dakota engineered to North Dakota's specific climate and associated construction window as well as additional engineering to support future carbon sequestration opportunities.
- Fund further work that supports the build-out of needed infrastructure at Marley Crossing, by working with suppliers (and the other project developers at Marley Crossing) to obtain the optimal infrastructure and input economics to pass through the final "gate" and began plant construction.
- Work with the State and Williams County to find solutions or mitigation strategies for any open challenges and/or risks that once mitigated can help to add Newlight to the state's portfolio of leading-edge technologies companies that will contribute to realizing the state's Carbon Neutral 2030 goal, CSEA's goals and benefit ND overall.

**Expected Results:**

- Complete the engineering and plant design through several milestone gates, including any special requirement needed in North Dakota.
- Construct, start up and operate AirCarbon plant in North Dakota.

**Duration:**

We expect the project will take approximately 35 months to complete after CSEA loan approval.

**Total Project Costs:**

We anticipate total project costs to be \$446 million.

**Participants:**

The participants include Newlight, Burns & McDonnell for FEL3/FEED and selected specialty contractors and consultants. EPC contractor to be confirmed at future date.

## PROJECT DESCRIPTION

### Objectives:

The long-term objective of the project is to increase the demand for State's renewable energy and plentiful methane gas through in-state production of a natural, biodegradable material that is a viable alternative to single-use plastic – AirCarbon. North Dakota has established an aggressive carbon neutral goal by 2030, and a key component of that will be finding environmentally sound, local uses for natural gas that does not rely on pipeline delivery out of state. We believe that AirCarbon production become a major component of that goal. For us, achievement of the long-term goal requires the execution on a set of near-term project phases. The second phase of the overall project (this funding request) is focused on engineering, design, and the cost of infrastructure build-out as well as leveraging the work that has been done in the State in the carbon sequestration area.

### *Single-Use Plastics and AirCarbon*

Single-use plastics made from petroleum are not bio-degradable. They are the cause of massive environmental problems that are forcing many governments to implement or consider restrictions. However, most experts forecast large increases in plastic demand due to the low-cost to produce and the high costs of making materials that have the same performance characteristics. Some newer materials are compostable. These products only degrade when disposed into hot industrial composts, of which there are limited only few. In contrast, AirCarbon is able to degrade in natural environmental conditions, including in home compost, soil, and other environments. AirCarbon has been certified "Plastic-Free" by Oceanic Global and pass home, soil, and water compostability testing through TUV Austria, one of the world's leading end-of-life certification bodies.

An estimated 17.6 billion pounds of plastic enter the marine environment every year, resulting in government bans and restrictions on using single-use plastics around the globe. While there have been significant efforts to replace single-use plastics with other materials, implementation has been slow due to their cost structure, performance characteristics, or limited degradability.

After 19 years in development, Newlight has developed an innovative technology that overcomes those barriers - a natural, regenerative, carbon-negative material that utilizes air and methane or CO<sub>2</sub> gas (instead of petroleum) as feedstock inputs.

AirCarbon is also known as PHB, and PHB is produced throughout nature, including by ocean-based micro-organisms that consume carbon in the form of methane or CO<sub>2</sub>. AirCarbon is environmentally degradable because microorganisms in the environment recognize it as a natural food source. It melts for forming products (at around 350<sup>oF</sup>) and is durable in hot and cold conditions (also making it SGS-certified dishwasher-safe).



*Newlight's California Headquarters & Air Carbon cutlery*

*Project Description - High Level Project Approach:*

The objective is to construct and operate an AirCarbon plant and the approach is designed into four phases (see below). While Newlight has signed an agreement to build its next plant in Ohio, Phase I was focused on understanding the viability of where to locate a future plant in North Dakota. Upon approval by Newlight's board, we are prepared to execute FEL3/FEED phase in order to prepare for detailed design and construction completion in 2026.

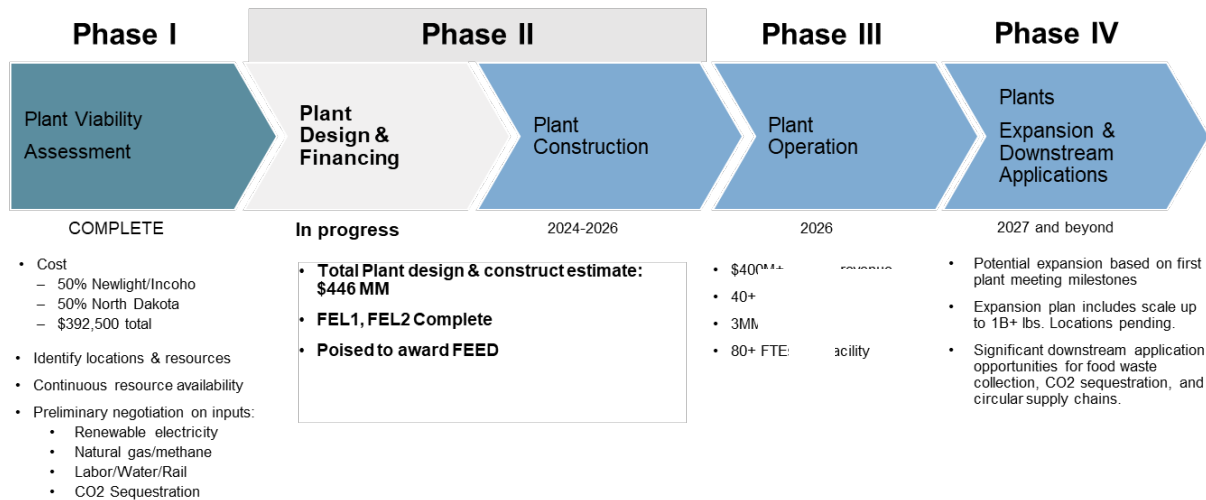

The progress during and since the completion of Phase I includes the following:

- **Engineering and Design:** The FEL2 (30%) design has been completed for the Ohio site and the ISBL process design will be very similar for the North Dakota site. Preliminary FEL3/FEED design work has commenced. Newlight has been investing and will continue to invest in this effort through the CSEA evaluation period, showing a commitment to the development of the project in North Dakota.
- **Site Selection:** The evaluation of site options across western ND was narrowed down to be around the Marley Crossing/Savage Services operations to support transportation logistics. We have not yet selected a specific site. Newlight has signed a contract with a site in Ohio but is still very interested in developing a second site in North Dakota. Newlight will enlist local contractors to support finalizing a site if this loan request is accepted.
- **Equipment & Labor:** Some of the equipment and infrastructure needed for the plant are long lead time, particularly the large complex reactor vessels, electrical gear, waste water treatment plant, etc. We plan to leverage the logistics practices for the adjacent facilities in order to plan for deliveries to our site. We will optimize use of local firms for goods and services supply. Newlight will leverage the FEED contractor for conducting labor studies and equipment deliveries throughout FEED execution.
- **Infrastructure Requirements, Key Cost Drivers & Implications for Total Installed Cost Estimation:**  
Two key cost drivers with a high degree of sensitivity and risk for AirCarbon production are electricity and gas costs. The estimate of these two drivers out of Phase I were at an FEL1 accuracy due to market variability and greenfield infrastructure options still under development. Understanding and mitigating buildout challenges will be critical in the success of the project.

We also have interest in the State's carbon sequestration strategy and will be evaluating the options to drive value.

- **State Support:** Thus far, the North Dakota Commerce Department has been very helpful in listening our requirements and providing early FEED funding. The Marley Crossing site is a greenfield location that does not yet have established infrastructure to deliver the power, gas, and water to our specifications. Understanding and participating in the development and availability (e.g., reliability and timing) of that infrastructure is an important step to the success of the project.

## Methodology

A milestone-based gated approach to perform projects aligns project objectives with the business needs to execute the projects in the most efficient way. The gates methodology is a process of progressive

definition of the project. This process is based on a planned and standardized series of reviews (gates) at the end of each phase.

This breakdown in phases or stages and the normalized control points at each end is an improvement of the classic approach, where the organizations may have points of control, but they are not as standardized as the ones that this technique offers. Gates methodology is consistent with Construction Industry Institute Best Practices.

Based on the progress made in Phase I, Phase II will have two parts. The first part will have several goals that we will organize into milestones to review at specific “gates” that include the following:

**Engineering and Design:** Manage FEED Contractor to update the engineering design to include the option of operating in the ND climate 7/24/365, completing FEED to include changes that incorporate the North Dakota operating climate. Identifying and requisition key long lead equipment and activities during FEL3 will minimize overall project schedule. The inside battery limits engineering design effort in many ways is common to the Ohio and Marley Crossing developments which benefits the overall project schedule. The initial grant will cover the FEED component for the installation in North Dakota. We are sharing the engineering costs with a focus on the infrastructure requirements for the North Dakota installation.

This methodology drives a common base plant design (exception is the cold weather design components specific to North Dakota), thus sharing the engineering design across the two facilities.

- **Site Layout :** The management team visited the Trenton area and noted the appeal of a few specific sites in the Marley Crossing area that could meet requirements with the proposed infrastructure build out. In Phase II we plan to narrow down and focus on the optimal site and developing plot plans and general arrangement drawings that are aligned across the two sites for inside battery limits.
- Validate equipment deliveries, cost estimate and current labor studies for the region.
- **Finalize Infrastructure Requirements & Implications for Economic Evaluation:** In FEED we plan to focus on the key cost drivers (e.g., electricity, gas, water & carbon sequestration) and the supporting infrastructure costs to better refine overall economic evaluation. This includes working with and supporting the Trenton Infrastructure group to design win/win solutions for all stakeholders (e.g., companies locating at Trenton, County & State organizations).

An important example of this is power. Finding and/or developing a reliable, renewable power source that also meets economic targets is a critical success factor.

- **State Support:** As the project continues to progress, we will work with the local authorities and vocational programs to identify local contractors and training initiatives to support the project.

### **Anticipated Results:**

We anticipate that completing FEED will provide us with the engineering plans and detailed infrastructure insights and other needed information to allow us to make a well-informed decision regarding the plant operations to meet targeted economics. We will continue to focus on refining the key value drivers (e.g., cost inputs) and mitigate any key risks. FEED work will include:

- **Engineering and Design:** Provide specific list of deliverables suitable to move forward into EPC. These deliverables will support both locations, Ohio and North Dakota, and will include climate-specific components.
- **Site Selection:** Site location and overall sit plan will be finalized early in FEED for North Dakota.
- **Equipment and Labor:** Labor costs and availability will be developed based on the most recent labor study. Preliminary quotes or firm quotes for 85% of equipment costs will have been received by the end of FEED.

### **Infrastructure Requirements & Implications to Total Installed Cost:**

This will require more informed assessment of key operating inputs including assessing the reliability/availability timing, input quality (e.g., methane gas target of 90%) and cost (commodity and infrastructure) for the key operating inputs (e.g., electricity, gas and water including potable, cooling, and waste management). We anticipate and plan to support the Trenton Infrastructure group to design win/win infrastructure solutions for all stakeholders (e.g., companies locating at Trenton, County & State organizations). Finally, we anticipate identifying potential partners and strategies to support the State's carbon sequestration goals to further optimize our economics and ESG goals.

We will conduct meetings with and gain commitments from key infrastructure utility providers to validate timelines and delivery volumes that can support the project.

- **State & County Support:** During Phase II, the plan is to work with the ND Commerce Department to articulate any needs such that the State/County is aware of project status and can continue to support the ongoing project installation.

With the completion of the FEED scope, we believe the State will see that Newlight has demonstrated due diligence in defining the scope of the work in the region where it is to be constructed before moving into detailed engineering and construction. This will provide a level of comfort that the State can add Newlight and AirCarbon production to the State's portfolio of new vibrant, leading-edge technologies

and companies that are selecting ND and contributing to its Carbon Neutral goal. The output of the above work will produce a high-level work plan that considers, integrates and optimizes realization of Newlight's and the State's (e.g., infrastructure support) goals.

**Facilities:**

Owner facilities at the site location will be required upon mobilization to the active construction site.



**Resources:**

We will employ a number of resources but to a large part the following partners will be the focus:

- Newlight subject matter experts
- Burns & McDonnell Engineering
- Trenton Infrastructure partners (including ND State and the County)
- EERC (carbon sequestration expertise)
- Key ND equipment fabricators
- Subject matter experts and consultants

Other consultants or services to be used may include electricity pricing experts, site selection contractors, and legal advisors for purchasing and sales agreements and we will try to utilize ND experts where possible. Environmental consultants will be required to support project development and assist during reviews with the North Dakota Department of Environmental Quality. State organizations will be contacted with respect to permitting requirements and we will continue to work with the Commerce Department to best position the plant for success.

**Techniques to Be Used, Their Availability and Capability:**

We plan to utilize a number of techniques to complete the work effort as listed below.

- OSHA best practices
- Reliability and Maintainability analysis
- Construction Industry Institute Best Practices
- Advanced work packaging
- Continuous financial model update
- Labor Studies
- Continuous evaluation of risk profile (Risk management workshops)
- Logistics planning studies

If we recognize the need for additional capability the project team will include local contractors, legal support, and technical consultants prior to looking outside ND.

**Environmental and Economic Impacts while Project is Underway:**

Environmental impacts and risks will be identified in FEED and any mitigations needed will be delineated for the EPC contractor.

### **Ultimate Technological and Economic Impacts:**

While the FEED phase of the project is to support development of EPC and infrastructure requirements of building an AirCarbon plant near gas facilities in North Dakota. The ultimate goal of the project is to create an entirely new industry based on a new way to utilize gas and energy. That new industry: AirCarbon products.

AirCarbon is expected to be able to compete favorably with traditional oil-based plastic as well as with other alternative polymers both in functionality and price with the “right” input cost structure. This assumes that we can produce AirCarbon with inputs sourced at the “right” cost, quality and reliability requirements that will allow us to successfully compete in the marketplace. If we produce AirCarbon at competitive levels, then we can expect continued economic impact growth from the planned plant as well as any potential expansion efforts based on market needs.

This effort will also create secondary benefits for North Dakota-based suppliers of gas, renewable wind energy, transportation, and other employers. And most importantly, it will create continued demand for the state’s plentiful carbon resources that cannot rely on interstate pipelines for delivery and instead use the gas in North Dakota to support the growth of its own value-added industrial base.

The infrastructure build-out will ultimately also support the entire Marley Crossing development, the companies that supply the inputs, and the region in general. The area will see development and employment from the plant, the construction, and the ancillary businesses surrounding the development through cost sharing and infrastructure development that may offset the ups/down economic cycles associated with the current carbon industry.

Once Phase II is successfully complete we will operate a plant that will employ 70-100 people directly, with many more that were involved in construction. This will spur secondary developments in the Williston/Trenton region, and the project has support from other development partners and the county economic development office.

### **Why the Project is Needed:**

North Dakota’s Bakken region was blessed with plentiful oil and gas. Over time, the oil/gas ratio (OGR) has increased, and the North Dakota Pipeline Authority predicts that ratio to continue. They also predict that output may exceed pipeline capacity in the near future. It will be critical to the state and the energy sector to find “local” productive use for that amount of gas, and an industry that uses gas without reliance on limited and intra/interstate pipeline capacity is of great interest. Introducing AirCarbon production locally in the Bakken where that excess gas can be used to make an environmentally friendly, carbon-negative, ocean-safe plastic alternative is one logical solution.

This also supports the Governor’s 2030 Carbon Neutral target. Newlight will essentially sequester carbon in the product during its useful life. It is our intent to find a way to harness renewable power, and to sequester any carbon dioxide that is produced during AirCarbon production. Also, it provides a very

tangible product that people of all persuasions can touch and feel and understand the story of how forks, knives, spoons, and straws are helping an energy-producing state become carbon-neutral. AirCarbon made from North Dakota methane will represent a product that is biodegradable in nature and will not accumulate in the oceans.

Finally, our intent is for this to be a first plant and we intend to expand as the market for AirCarbon grows. For the plant under consideration in this application, which would provide 70-100 environmentally attractive jobs that provides North Dakotan's the opportunity to work for a leading technology company in a growing industry. As the company grows, so will the economic and social benefits to the state.

## STANDARDS OF SUCCESS

The project will support the design and operations of an economically viable plant that meets Newlight's success criteria. Those criteria include:

- Safety in Construction and Operations
- Achieving a design that will meet economic performance thresholds.
- Engineering to meet specific North Dakota challenges.
- Confidence that when plant construction commences, the economics and infrastructure and delivery mechanisms (pipeline, waterline/s, or powerlines) are in place to meet the construction timelines with adequate lead times to alleviate any potential construction/operating delays.

If successful, Newlight will move to finance and build North Dakota's first AirCarbon plant. Developing an AirCarbon industrial base in North Dakota can support the state's energy sector by increasing demand for renewable energy, providing a new market for gas feedstocks (which supports further build out of gas gathering assets leading to a reduction in flaring) while promoting the state of North Dakota as a leader in innovative environmental stewardship.

To move the project into Phase III, Newlight needs to complete the engineering, construction, and commissioning.

Upon completion of engineering and design, Newlight will transition into the construction phase that includes:

- A significant number of indirect design, supply and construction jobs in North Dakota.
- A plant that will, when operational, will create 100 environmentally friendly jobs over the next five years.
- Increase in supplier revenues and jobs to support plant inputs, especially renewable energy, water, and gas/CO<sub>2</sub> feedstock and transportation costs.

## **BACKGROUND/QUALIFICATIONS:**

### **Newlight Technology and Burns & McDonnell**

Founded in 2003, Newlight is a nature-inspired biotechnology company based in California that is converting air and greenhouse gas into a biomaterial called AirCarbon®. Newlight uses a technology that is found in ecosystems throughout the world, including in the ocean, wherein naturally-occurring microorganisms consume air and greenhouse gas, including methane and carbon dioxide, through fermentation to produce a muscle-like material inside of their cells called PHB. PHB is an energy storage material made in most living organisms, from marine microorganisms to the roots of plants, and can be melted into shapes as a replacement for plastic. Newlight is the first company to directly transform greenhouse gases into PHB, a biomaterial that the company calls AirCarbon, at commercial scale. AirCarbon competes on performance with various grades of polypropylene, the second largest-volume plastic in the world. With a variety of potential industries to serve, Newlight's primary focus is on addressing ocean plastic pollution by displacing plastic in the foodware market, starting with straws, cutlery, and coated paper products. In addition to foodware, Newlight is also seeding expansion in automotive and fashion applications. Newlight launched its first commercial-scale AirCarbon production facility in 2020, and today Newlight's customers and partners include Shake Shack, Nike, Target, H&M, Ben & Jerry's, Sumitomo, US Foods, and Sysco, with millions of AirCarbon units delivered to consumers to date.

Burns & McDonnell is a family of companies bringing together an unmatched team of more than 13,500 engineers, construction and craft professionals, architects, planners, technologists and scientists to design and build our critical infrastructure. With an integrated construction and design mindset, we offer full-service capabilities. Founded in 1898 and working from 70 offices globally, Burns & McDonnell is ranked 7th on the 2023 annual survey of Top 500 Design Firms by Engineering News-Record (ENR) magazine and is 100% employee-owned.

### ***Mark Herrema, CEO***



Mark Herrema is the co-founder and CEO of Newlight Technologies. In 2003, Mark co-founded Newlight with Kenton Kimmel with a vision of using greenhouse gas as a resource to make high-performance sustainable materials. Newlight has been honored to receive industry recognition as “Biomaterial of the Year” by the Nova Institute, “Innovation of the Year” by Popular Science, and “Technology Pioneer” by the World Economic Forum. In 2016, Newlight was awarded the Presidential Green Chemistry Challenge Award by the U.S. Environmental Protection Agency. Mark graduated magna cum laude from Princeton University, and has since garnered 19 years of experience in process engineering, polymer functionalization, and strategic business development.

***Kenton Kimmel, CTO***



As CTO and co-founder of Newlight, Kenton has over 19 years of industrial experience in chemical, process, electrical, mechanical, and automation engineering. Kenton has been instrumental in the design, scale-up, and optimization of the company's biomaterial manufacturing technology, including the engineering, construction, commissioning, and optimization of the company's production lines. Prior to his work at Newlight, Kenton held a position in the In Vitro Microbiology Group at Allergan Pharmaceuticals where he conducted research on genetic markers and gene expression of potent neurotoxins for use in cosmetic surgery. Kenton graduated from Northwestern University with a Biomedical Engineering B.S.E degree, double specializing in Biomaterials & Biotechnology and Transport Processes & Tissue Engineering.

***Evan Creelman, Chief Business Development Officer***



Evan Creelman joined Newlight in 2006 and has been prominent in the creation of Newlight's extensive network of development and commercial partners. Evan now leads the company's business development efforts, and prior to joining Newlight, Evan worked with Mercer Management Consulting in the Airline, Retail, and Private Equity industries. Evan graduated cum laude from Northwestern University with a degree in Applied Mathematics & Economics, holds a master's in accounting from the University of California - Irvine, and is a Chartered Financial Analysis® (CFA).

***Rob Clark, Corporate Project Director***

More than 40 years' experience in project management as owner or contractor, in diversified international and regional project management, engineering and construction, with project sizes up to 30 billion dollars. Rob was VP-Project Director on a project awarded the Hydrocarbon Processing Petrochemical Project of the Year. Rob's projects have always been onshore, downstream, in the areas of refining, petrochemicals, power and environmental, with projects executed in Europe, Asia, North and South America. He has presented at conferences in Asia and the U.S. on EPC topics such as Front- End Engineering Design (FEED), Risk, Ethane and Ethylene, Site Selection and Construction Labor. He was active on the Construction Industry Institute Research Team for Modularization.

## **MANAGEMENT**

Our partner Burns & McDonnell is a recognized expert in their field. Newlight has previous experience working with the firm and is confident in their management techniques.

Burns & McDonnell is a family of companies bringing together an unmatched team of more than 13,500 engineers, construction and craft professionals, architects, planners, technologists and scientists to design and build our critical infrastructure. With an integrated construction and design mindset, we offer full-service capabilities. Founded in 1898 and working from 70 offices globally, Burns & McDonnell is ranked 7th on the 2023 annual survey of Top 500 Design Firms by Engineering News-Record (ENR) magazine and is 100% employee-owned.

The ability to manage a project of this size requires the team to be able to deliver each stage of the project in a structured, stepwise manner. The project shall be progressed in a proven, industry standard stage gated process, consistent with the Construction Industry Institute Best Practices. The approach will continuously develop further quantification and reduction of risk, with refinement and development of cost and schedule to ensure project certainty.

The project team shall combine global best practices, reviewing past lessons learned providing the team with inputs to craft a fit for purpose project execution strategy.

As Newlight has developed they have assembled a multi-cultural project execution team with experience in projects up to \$30 billion dollars.

## TIMETABLE

Our proposal aligns the already completed FEL1 and FEL2 engineering and design work to build this plant through a set of logical milestones that will align with the project’s reporting and funding through CSEA. Funding will be used to contract our engineering firm, Burns & McDonnell, and support Construction and Commissioning of the North Dakota plant as well as support our work to develop the Marley Crossing infrastructure plans.

The below Gantt chart shows the detailed engineering milestone plan and timing.

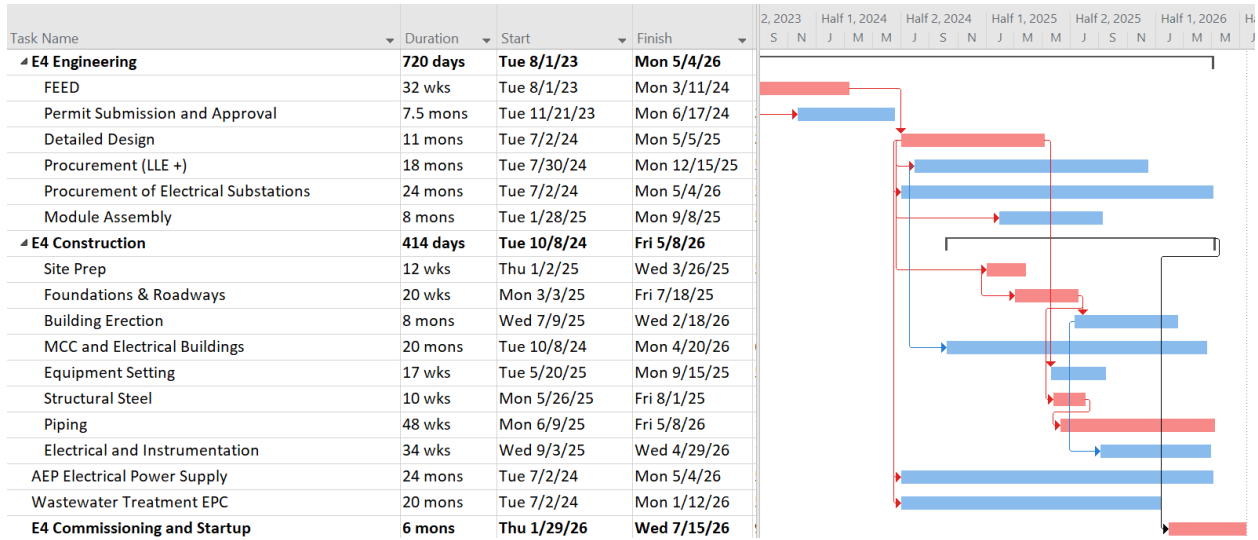



## BUDGET

Please use the table below to provide an **itemized list** of the project’s capital costs; direct operating costs, including salaries; and indirect costs; and an explanation of which of these costs will be supported by the financial assistance and in what amount. The budget should identify all other committed and prospective funding sources and the amount of funding from each source. **Please feel free to add columns and rows as needed.** Higher priority will be given to projects with a high degree of matching private industry investment.

Project Associated Expense	NDIC Grant	NDIC Loan	Applicant’s Share (Cash)	Other Project Sponsor’s Share	Total
FEED	\$4,185,625 (2022 grant)		\$12,814,375		\$17MM
Detailed Engineering & LLE		\$59 MM	\$59 MM		\$118 MM
Procurement & Construction		\$91 MM	\$207 MM		\$298 MM
Commissioning & Start Up			\$13 MM		\$13 MM
<b>Total</b>	\$4,185,625 (2022 grant)	\$150,000,000	\$291,814,375		\$446,000,000

These estimates are based on experience in estimating and quoting similar projects.

## **CONFIDENTIAL INFORMATION**

A person or entity may file a request with the Commission to have material(s) designated as confidential. By law, the request is confidential. The request for confidentiality should be strictly limited to information that meets the criteria to be identified as trade secrets or commercial, financial, or proprietary information. The Commission shall examine the request and determine whether the information meets the criteria. Until such time as the Commission meets and reviews the request for confidentiality, the portions of the application for which confidentiality is being requested shall be held, on a provisional basis, as confidential.

If the confidentiality request is denied, the Commission shall notify the requester and the requester may ask for the return of the information and the request within 10 days of the notice. If no return is sought, the information and request are public record.

Note: Information wished to be considered as confidential should be placed in separate appendices along with the confidentiality request. The appendices must be clearly labeled as confidential. If you plan to request confidentiality for **reports** if the proposal is successful, a request must still be provided.

To request confidentiality, please use the template available at <http://www.nd.gov/ndic/CSEA-app-doc-infopage.htm>.

## **PATENTS/RIGHTS TO TECHNICAL DATA**

*Any patents or rights that the applicant wishes to reserve must be identified in the application. If this does not apply to your proposal, please note that below.*

## **STATE PROGRAMS AND INCENTIVES**

As mentioned, Phase 1 of the project was provided with 50% funding via the Renewable Energy Program. The total project cost was \$392,500, of which the state funded 50% or \$196,250. This Phase was completed in January 2022, resulting in a positive feasibility with 5 locations presented and evaluated. Of these, the Marley Crossing/Trenton site adjacent to the Savage Services location was the top site.

Newlight also received a CSEA grant in 2022 to support FEED engineering for an AirCarbon plant in North Dakota. The total project FEED cost was forecasted at \$8,371,250 of which the state grant will fund 50% or up to \$4,185,625. This work has not yet commenced and is expected to be initiated in 2023 with completion in 2024. We are requesting another \$150MM for the project in North Dakota. While the first plant is planned to be constructed in Ohio, we are confident we can construct an additional plant in North Dakota.

These are the only state programs that Newlight has participated in.

## Appendix – Letters of Support



Wellspring Hydro  
PO Box 884  
Williston, ND 58802-0884  
701-770-8682

To ND Clean Sustainable Energy Authority,

It is our understanding that NewLight Technologies, Inc. of Huntington Beach, CA is applying for CSEA funding. Wellspring Hydro would like to extend this letter of support for their project on the merits of their technology and the co-beneficial nature of their project to ours and others who are looking to build new petro-chemical facilities in Northwest North Dakota.

We applaud their proposed use of natural gas in Northwest North Dakota and add value to our natural gas here instead of sending it out of the state. The use of that gas here opens the door for additional oil development which is critical for the future of North Dakota. They are also creating products that reduce our dependence on single use plastics which don't break down easily in the environment, their known to the earth products do break down naturally in the environment and are made in a carbon negative way.

They will provide 50-70 new jobs that never existed before which will help us diversify our economy and make us less dependent on the whipsaw effect of the ups and downs of oil prices. They will also likely support our company, Wellspring Hydro, by purchasing products we make at our chlor alkali facility which highlights the importance of having a reliable, stable, and secure supply of commodities such as caustic soda and hydrochloric acid. We urge you to support their project with funding from the Clean Sustainable Energy Authority.

Yours truly,

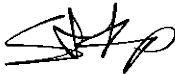

Steve Kemp  
Founder  
Wellspring Hydro  
[stevek@wellspringhydro.com](mailto:stevek@wellspringhydro.com)  
701-770-8682



Feb 23, 2022

Al Anderson  
Director, Clean Sustainable Energy Authority  
State Capital, 14th Floor  
600 E. Boulevard Avenue Dept 405  
Bismarck, ND 58505-0840

Director Anderson,

Williston Economic Development is delighted to support the New Technologies Plant project as submitted to CSEA.

Diversification has always been a key component of our economic development efforts. A project of this magnitude that is a carbon-negative enterprise, utilizes local feedstock of natural gas and will support 50-70 permanent full-time jobs is a winning formula for the community and the region.

In closing, the potential benefit to our community in both economic growth and quality of life is great. On behalf Williston Economic Development, I urge you to fully support their efforts.

Best Regards,

A handwritten signature in black ink, appearing to read "Shawn Wenko".

Shawn Wenko  
Executive Director  
Williston Economic Development



PO Box 1047  
3200 West Holly Street  
Sidney, MT 5927  
Phone: (406) 488-1602  
Fax: (406) 488-6524  
www.Lyrec.com

2/28/2022

To whom it may concern,

Lower Yellowstone Rural Electric Cooperative (LYREC) has provided electric service to rural America for the past 85 years. The purpose of the cooperative was to provide electrical service to rural America and support the residential farms, commercial businesses, and communities in our service territory, which includes both North Dakota and Montana. One of the guiding principles of a cooperative is to support the communities and members we serve and help them succeed.

In reviewing the information provided by NewLight Technologies, Inc. of Huntington Beach, CA, and after several discussions with their representative, LYREC plans to support the project they are proposing. NewLight Technologies, Inc. has developed an impressive product that is conscious of the environmental impact and will decrease the single use plastics.

LYREC feels the economic impact, both short and long term, makes this a promising business to support. This project will not only effect the membership of LYREC in North Dakota, but also across the state line into Montana.

NewLight Technologies, Inc. will likely bring jobs and economic growth to the area, along with diversity. As an electrical company, we support projects that allow stability in the electric market and promote the use of resources in our region.

We urge the ND Clean Sustainable Energy Authority to support NewLight Technologies, Inc. as they apply for funding.

Sincerely,

Jason A. Brothen  
CEO, Lower Yellowstone Rural Electric Cooperative



P.O. Box 2747  
Fargo, ND 58108

December 10, 2020

North Dakota Industrial Commission  
Renewable Energy Council  
c/o Karlene Fine  
Industrial Commission  
State Capitol 14th Floor  
600 E. Boulevard Ave. Dept. 405  
Bismarck, ND 58505-0840

Dear Ms. Fine,

**RE: Support for EERC proposal by Incho Advanced Materials to examine the viability of utilizing excess gas feedstock in North Dakota and determine optimal locations and partners for production of bio-degradable PIIB.**

Xcel Energy is pleased to support Incho Advanced Materials' application to the Renewable Energy Council to assess the viability of introducing a new industry to North Dakota that would create additional demand for the state's energy and renewable energy sectors.

Introducing a new technology-based industry that complements the existing energy industry and infrastructure is a long-term goal of the industry and the State and would also generate new energy sector jobs in the state as well as help the State in meeting key stated goals (e.g., flaring reduction). A new industrial base that manufactures materials that can have a positive impact on the environment is also a benefit of this project.

Due to this favorable impact to the state and its energy sector, we support this application.

Sincerely,

A handwritten signature in blue ink that reads 'Mark Nisbet'.

**Mark Nisbet**  
Xcel Energy  
North Dakota Principal Manager  
2302 Great Northern Drive, Fargo, ND 58102  
P: 701.241.8607 C: 701.371.5255 F: 701.241.8682  
E: [mark.nisbet@xcelenergy.com](mailto:mark.nisbet@xcelenergy.com)

Submitted by: Rainbow Energy Center  
 Project Duration: 30 months  
 Total Project Costs: \$85,000,000  
 Request for: \$42,500,000 loan

**Summary of Project:** This project supports the commercialization of recycling of bottom ash and flue gas desulfurization materials at Coal Creek Station for beneficial reuse.

### Technical Review Results

Overall Technically Sound (256/315)	
Good	3
Fair	
Questionable	

### BND Economic Feasibility Recommendation

Overall Economic Feasibility	
Yes	X
No	

### Technical Committee Scores

	Score (Out of 50)
Charlie Gorecki	43
Josh Teigen	42
Dave Glatt	43
Lynn Helms	43
Justin Kringstad	43
Rachel Retterath	46
Todd Steinwand	36
John Weeda	50

Average: 43

**Recommendation: 8-0 Consider funding**



# TECHNICAL REVIEWERS' RATING SUMMARY

## C-04-F

Lignite Combustion Product Enhancements

Submitted By: Rainbow Energy Center

Date of Application: May 2023

**Request for \$42,500,000 Loan**

**Total Project Costs \$85,000,000**

Rating Category	Weighting Factor	Technical Reviewer			Average Weighted Score
		F1 Rating	F2 Rating	F3 Rating	
1. Objectives	3	4	5	4	13
2. Impact	9	4	4	4	36
3. Methodology	9	4	4	4	36
4. Facilities	3	4	5	4	13
5. Budget	9	4	5	3	36
6. Partnerships	9	4	5	4	39
7. Awareness	3	4	4	3	11
8. Contribution	6	4	4	3	22
9. Project Management	6	4	4	4	24
10. Background	6	4	5	4	26
	315	252	282	234	256

**OVERALL TECHNICALLY SOUND**

GOOD (IF > 214)	<input checked="" type="checkbox"/>	<input checked="" type="checkbox"/>	<input checked="" type="checkbox"/>
FAIR (200-213)	<input type="checkbox"/>	<input type="checkbox"/>	<input type="checkbox"/>
QUESTIONABLE (IF < 200)	<input type="checkbox"/>	<input type="checkbox"/>	<input type="checkbox"/>

Mandatory Requirements	F1		F2		F3	
	Yes	No	Yes	No	Yes	No
Diversification Delivery:						
Project enhances the production of clean sustainable energy, to make the State a world leader in the production of clean sustainable energy, and/or to diversify and grow the State's economy.	✓		✓		✓	
Commercialization or Development/Expansion:						
Concept will lead to the <b>large-scale development and commercialization</b> of projects, processes, activities, and technologies that reduce environmental impacts and/or increase sustainability of energy production and delivery.	✓		✓		✓	

In State Requirement:	Yes	No	Yes	No	Yes	No
The funds distributed from the financial assistance are to be applied to support in-state activities and must have other sources of financial support.	✓		✓		✓	

- The objectives or goals of the proposed project with respect to clarity and consistency with Clean Sustainable Clean Energy Authority goals of projects, processes, activities, and technologies that reduce environmental impacts and increase sustainability of energy production and delivery are: 1 – very unclear; 2 – unclear; 3 – clear; 4 – very clear; or 5 – exceptionally clear.**

**Reviewer F1 (Rating 4)**

The objectives are clear and consistent with CSEA goals.

**Reviewer F2 (Rating 5)**

The project clearly fits the goals of the CSEA with a focus on commercial application of technology to for a reduced environmental footprint and increased sustainability of energy production and delivery. They propose to commercially apply technology to turn bottom ash and scrubber materials into marketable projects. This is driven by ash markets, economics, and environmental improvements.

**Reviewer F3 (Rating 4)**

Projects' goal is to optimize the beneficial use of Bottom Ash and Flue Gas Desulfurization sludge to commercial grade materials versus current permanent storage. It will be the 1st of its kind in North Dakota.

- The objectives will make a difference in the near term to the state's economy: 1 – no impact; 2 – small impact; 3 – likely impact; 4 – most likely impact; or 5 – significant impact.**

**Reviewer F1 (Rating 4)**

The objectives will most likely impact this state's economy.

**Reviewer F2 (Rating 4)**

As the proposal states, the project would add value to North Dakota through growing and diversifying the state's economy. Not only will the project provide new marketable products while removing material disposal requirements, but it will also help sustain the operation Coal Creek Station and its economic impact. The project would also provide a model for other plants to consider for some of their coal related residues.

**Reviewer F3 (Rating 4)**

Conversion of Scrubber sludge to 175,000t/yr of gypsum and the 300,000 t/yr of Bottom Ash for building aggregate (both marketable products) from storage, reduces the environmental impact of the stored material and creates additional materials for the marketplace. Less CO2 will be generated from concrete production. Energy sustainability is better for the overall generation stability and availability.

- 3. The quality and clarity of the methodology in the proposal is: 1 – well below average; 2 – below average; 3 – average; 4 – above average; or 5 – well above average.**

**Reviewer F1 (Rating 4)**

The quality of the methodology is above average.

**Reviewer F2 (Rating 4)**

The proposal lays out the technology and business methodologies of the project. The technology implementation and market opportunities are well understood by REC and their project team.

**Reviewer F3 (Rating 4)**

Rainbow Energy will manage the 30 month project. Barr Engineering will provide the FGD dewatering system and gypsum production to be used for agricultural soil amendment. EcoMaterial Technologies, Inc. will supply the bottom ash conversion technology.

- 4. The facilities and equipment available and to be purchased for the proposed pilot or commercialization strategy is: 1 – very inadequate; 2 – inadequate; 3 – adequate; 4 – notably good; or 5 – exceptionally good.**

**Reviewer F1 (Rating 4)**

The facilities and equipment available is notably good for this project.

**Reviewer F2 (Rating 5)**

The necessary equipment is available and can be purchased so this is a strength of the project.

**Reviewer F3 (Rating 4)**

Current fly ash produced is being marketed by EcoMaterial. Both technologies have been proven and installed elsewhere. Local suppliers and contractors will be utilized for equipment and installation.

- 5. The proposed budget is comprehensive and sufficient relative to the outlined work and the timetable: 1 – not sufficient; 2 – possibly sufficient; 3 – likely sufficient; 4 – most likely sufficient; or 5 – certainly sufficient.**

**Reviewer F1 (Rating 4)**

The proposed budget is most likely sufficient for the work as outlined within the given timeframe.

**Reviewer F2 (Rating 5)**

They have performed the upfront work to understand the schedule and budget requirements. The team is equipped to deal with any challenges that may come up, and they have the process for tracking the project and costs.

**Reviewer F3 (Rating 3)**

NDIC is being asked for \$42.4MM of a \$85MM or 50% for the project to engineer, design, construct, commission, and startup. Half of the cost is being funded by the owner, Rainbow Energy, which indicates confidence in the technology.

- 6. The appropriate strategic partnerships are in place for short and long term plans to be successful: 1 – very limited; 2 – limited; 3 – adequate; 4 – better than average; or 5 – exceptional.**

**Reviewer F1 (Rating 4)**

Partnerships are in place to satisfy short term and long-term plans.

**Reviewer F2 (Rating 5)**

REC has put together the right strategic partnerships to execute this project. Coal Creek has a strong history of marketing their byproducts and REC combined with EcoMaterials Technology Inc and Barr Engineering provides the diverse expertise needed to make the project a success. The combined team is well equipped to cover the technology, market, and business aspects of the project.

**Reviewer F3 (Rating 4)**

Rainbow Energy and EcoMaterials have partnered for many years marketing all of the fly ash produced for cement substitute. Barr Engineering has worked at Coal Creek Station in the past on a variety of Plant improvements and retrofits.

- 7. The likelihood that the project approach (time & budget) will achieve its technical and market goals is: 1 – not achievable; 2 – possibly achievable; 3 – likely achievable; 4 – most likely achievable; or 5 – certainly achievable.**

**Reviewer F1 (Rating 4)**

The technical and marketing goals are most likely achievable within the stated time and budget.

**Reviewer F2 (Rating 4)**

The schedule and budget are well thought out and outlined in the proposal. The upfront work has been performed to understand the schedule and budget prior to final engineering and procurement.

**Reviewer F3 (Rating 3)**

It's a bit difficult to predict the outcome of a proposed 30 month project of this magnitude. The engineering and design phases should parallel predictions however once the procurement and construction take place, many variables (climate/location, etc.) could affect the time and budget.

- 8. The scientific and/or technical contribution of the proposed work to specifically address Clean Sustainable Energy Authority goals of impacting technology used in North Dakota's energy industries will likely be: 1 – extremely small; 2 – small; 3 – significant; 4 – very significant; or 5 – extremely significant.**

**Reviewer F1 (Rating 4)**

The scientific and technical contribution maybe very significant for CSEA goals. This area has been a long-term goal of the industry with yet unrealized full potential.

**Reviewer F2 (Rating 4)**

The project is a fit for the CSEA and the project can act as a model for dealing with similar materials from other North Dakota power plants. In addition to reducing the environmental

impact and increasing sustainability, using ash and scrubber solids for wallboard, concrete and agricultural operations can provide lower carbon footprint replacements for existing materials.

**Reviewer F3 (Rating 3)**

Significant environmental impact will be realized when FGD sludge and bottom ash are no longer stored in dewatering ponds; less concrete production will result in less CO<sub>2</sub>. In addition, additional revenue from marketing these materials increase the overall financial stability of the energy park and keeps available power on the grid.

- 9. The project management plan, including budgeting projections, partner connections and well-defined milestone chart is: 1 – very inadequate; 2 – inadequate; 3 – adequate; 4 – notably good; or 5 – exceptionally good.**

**Reviewer F1 (Rating 4)**

The project management plan is notable good. Additional graphics would facilitate ease of understanding.

**Reviewer F2 (Rating 4)**

The project management laid out by REC is designed to ensure project success by leading the project with support from their project partners.

**Reviewer F3 (Rating 4)**

The Gantt chart specifically calls out milestones, responsibilities, and updates to all partners as well as NDIC. Rainbow Energy will be overall project manager and will be providing schedule and budget updates.

- 10. The background and experience of the project principals with regards to technical qualifications and competence is: 1 – very limited; 2 – limited; 3 – adequate; 4 – better than average; or 5 – exceptional.**

**Reviewer F1 (Rating 4)**

The background and experience of the project principals is better than average and well suited for these applications.

**Reviewer F2 (Rating 5)**

This is a strength of the proposal. Coal Creek has a strong history of marketing their byproducts and REC combined with EcoMaterials Technology Inc and Barr Engineering provides the diverse expertise needed to make the project a success.

**Reviewer F3 (Rating 4)**

Rainbow Energy as owner and operator of Coal Creek has the experience and personnel to manage and provide support to contractors and procurement agents. Barr has installed FGD dewatering and gypsum systems before as has EcoMaterials experience in the blending of fly ash with bottom ash to expand the ash marketing capability.

---

**Section C. Overall Comments and Recommendations:**

**Please comment in a general way about the merits and flaws of the proposed project and make a recommendation whether or not the project is technically sound.**

**Reviewer F1**

To enhance revenue for the industry from the sales byproducts is a long standing objective of the industry. This proposal is a thorough and very complete effort to enhance revenues from byproduct sales.

**Reviewer F2**

It recommended that funding be approved. This project is a good fit for CSEA program by applying technology commercially to reduce the environmental impact and increase sustainability of energy supply at the Coal Creek Station. REC has put a solid team together to further increase their sale of ash and scrubber materials, growing and diversifying the state's economy. They have the team and plans in place for a successful project. This project can provide a model for other North Dakota power plants with similar byproducts.

**Reviewer F3**

All the elements and partners are in place to design and build facilities to eliminate storage of bottom ash and FGD sludge from Coal Creek improving the environmental impact from the station and providing additional material for marketing and improving the bottom line. Success should show to other ND as well as national generators the viability of converting stored material to marketable products. Success will also maintain reliable and affordable energy in North Dakota. In addition, this reviewer believes renewable energy generation will not meet current or future increased energy demand therefore, some more reliable and available alternative is necessary.



2875 Third Street SW  
Underwood, North Dakota  
58576  
701.207.9988  
rainbowenergycenter.com

May 19, 2023

North Dakota Industrial Commission

Attn: Clean Sustainable Energy Program  
State Capitol – Fourteenth Floor  
600 East Boulevard  
Bismarck, ND 58505

To whom it may concern:

Subject: Lignite Combustion Product Enhancement

Rainbow Energy Center is pleased to submit an original and one copy of the subject proposal in partnership with EcoMaterials Technologies, Inc. and Barr Engineering Co. The application solicits the support of the Clean Sustainable Energy Authority Program for the execution of a fully commercialized operation to optimize the beneficial use of both bottom ash material and flue gas desulfurization (FGD) materials at Coal Creek Station, an 1151-megawatt coal-fired power plant located between Washburn and Underwood, North Dakota. The proposed project will result in the commercial facilities necessary to process these materials to bring them to commercial grade for utilization as commodities as compared to permanent storage in solid waste facilities. Building on the experiences in other states, the project will launch a system of waste handling that is a first of its kind in North Dakota.

The project team proposes to advance on-site capabilities to manage coal combustion materials previously disposed of as waste and convert them into commodities ready to market through the region. The project team aims to serve as an example of how North Dakota can deploy additional technologies at existing coal-fired power plants to reduce CO<sub>2</sub> emissions, improve the marketability of coal combustion products, reduce waste and pursue Governor Burgum's goal of carbon neutrality by 2030.

If you have any questions, please contact Jessica Bell by phone at (701) 891-9708 or by e-mail at [jessica.bell@rainbowenergycenter.com](mailto:jessica.bell@rainbowenergycenter.com).

Sincerely,

A handwritten signature in black ink, appearing to read "Stacy L. Tschider".

Stacy L. Tschider  
President

Enclosures

Clean Sustainable Energy Authority

---

North Dakota Industrial Commission

## Application

**Project Title: Lignite Combustion Product Enhancements**

**Applicant: Rainbow Energy Center**

**Date of Application: May 19, 2022**

**Amount of Request**

**Grant: \$0**

**Loan: \$42,500,000**

**Total Amount of Proposed Project:  
\$85,000,000**

**Duration of Project: 30 months  
(May 2023 – October 2025)**

**Point of Contact (POC): Jessica K. Bell**

**POC Telephone: (701) 891-9708**

**POC E-Mail:**

**Jessica.Bell@rainbowenergycenter.com**

**POC Address: 918 E Divide Ave, Suite 400**

**Bismarck, ND 58501**



## TABLE OF CONTENTS

<b>Abstract</b>	<b>4</b>
<b>Project Description</b>	<b>5</b>
<b>Standards of Success</b>	<b>9</b>
<b>Background/Qualifications</b>	<b>10</b>
<b>Management</b>	<b>11</b>
<b>Timetable</b>	<b>12</b>
<b>Budget</b>	<b>14</b>
<b>Affidavit of Tax Liability</b>	<b>15</b>
<b>Confidential Information</b>	<b>16</b>
<b>State Programs and Incentives</b>	<b>18</b>
<b>EcoMaterial Technologies Inc. Bottom Ash</b>	<b>Appendix A</b>
<b>Barr Engineering Co. FGD Dewatering System Technology</b>	<b>Appendix B</b>
<b>Letters of Support</b>	<b>Appendix C</b>
<b>Qualifications of Key Personnel</b>	<b>Appendix D</b>
<b>Business Plan</b>	<b>Appendix E</b>
<b>Historical Financial Statements</b>	<b>Appendix F</b>
<b>Budgeted Projections</b>	<b>Appendix G</b>
<b>Loan Application</b>	<b>Appendix H</b>
<b>Industry Specifications for Coal Ash</b>	<b>Appendix I</b>
<b>Industry Specifications for Gypsum</b>	<b>Appendix J</b>
<b>EPA Study on FGD Beneficial Use on Agricultural Lands</b>	<b>Appendix K</b>
<b>Study of Fly Ash as a Cement Replacement</b>	<b>Appendix L</b>
<b>Site Layout Drawings</b>	<b>Appendix M</b>

## ABSTRACT

**Objective:** The objective of this project is to support the Clean Sustainable Energy Authority (CSEA) goal that focuses on the reduced environmental impacts and increased energy sustainability. The project also brings increased value to North Dakota. To support these objectives, the project team proposes to complete a fully commercialized operation to optimize the beneficial use of both bottom ash material and flue gas desulfurization (FGD) materials at Coal Creek Station, an 1151-megawatt coal-fired power plant located between Washburn and Underwood, North Dakota. The proposed project will result in the commercial facilities necessary to process these materials to bring them to commercial grade for utilization as commodities as compared to permanent storage in solid waste facilities. Building on the experiences in other states, the project will launch a system of lignite coal combustion material transformation that is a first of its kind in North Dakota. Project details include a) detailed design and costing of materials to build the drying and grinding facilities; b) engineering and material balances required to file for all project permits; and c) materials needed to commercialize enhanced management of coal combustion materials. The project team proposes to advance on-site capabilities to manage coal combustion materials previously disposed of in solid waste facilities and convert them into commodities ready to market throughout the region.

**Expected Results:** This project will establish a design basis and cost estimate possessing sufficient detail to support the final construction of equipment on site at Coal Creek Station. Upon its completion, Coal Creek Station will have the equipment needed to convert coal combustion materials such as bottom ash and FGD materials to commodity-grade products, including bottom ash at ASTM- C618-23<sup>E 1</sup> and quality gypsum material. Ultimately, this will result in technological advancements with our partners that reduce environmental impacts and increase sustainability of coal electricity production through reducing the amount of non-marketable products placed in permanent storage and CO<sub>2</sub> emissions. The project team aims to serve as an example of how North Dakota can deploy additional technologies at existing coal-fired power plants to reduce CO<sub>2</sub> emissions, improve the marketability of coal combustion products, reduce disposal of valuable products and pursue Governor Burgum's goal of carbon neutrality by 2030.

**Duration:** 30 months (May 2023 – October 2025)

**Total Project Cost:** The proposed total cost is \$85,000,000, with \$42,500,000 loan from the North Dakota Industrial Commission (NDIC) and \$42,500,000 cash from Rainbow Energy Center, LLC (Rainbow Energy Center).

**Participants:** The project lead is Rainbow Energy Center, and the project will be conducted in partnership with EcoMaterial Technologies, Inc., Barr Engineering Co. and NDIC through the Clean Sustainable Energy Authority.

## PROJECT DESCRIPTION

**Objectives:** The objective of this project is to support the Clean Sustainable Energy Authority (CSEA) goal that focuses on the reduced environmental impacts and increased energy sustainability. The project also brings increased value to North Dakota. To support these objectives, the project team proposes to complete a fully commercialized operation to optimize the beneficial use of both bottom ash material and flue gas desulfurization (FGD) materials at Coal Creek Station, an 1151-megawatt coal-fired power plant located between Washburn and Underwood, North Dakota. The proposed project will result in the commercial facilities necessary to process these materials to bring them to commercial grade for utilization as commodities as compared to permanent storage in solid waste facilities. Building on the experiences in other states, the project will launch a system of lignite coal combustion material transformation that is the first of its kind in North Dakota. Project details include a) detailed design and costing of materials to build the drying and grinding facilities; b) engineering and material balances required to file for all project permits; and c) materials needed to commercialize enhanced management of coal combustion materials. The project team proposes to advance on-site capabilities to manage coal combustion materials previously disposed of in solid waste facilities and convert them into commodities ready to market throughout the region.

**Methodology:** The tasks for this project are outlined in the details below. Barr Engineering Co. will work concurrently with EcoMaterial Technologies and REC staff to implement the initiatives outlined in this proposal to be completed by June of 2025. Engineering and design details will be completed for both facilities prior to construction commencement. Upon completion of construction, facilities will operate as outlined in the details provided in this application.

**Project Management and Planning:** The management of all project activities will be performed by REC personnel over the duration of the project period of performance as well as the operation of the facilities. Barr Engineering Co and EcoMaterials Technology Inc will be resources for these tasks that include communication of project activities and direction with the project team to provide updates and obtain inputs to prioritize the project focus. Specific activities will include task coordination, risk management/mediation, managing budget resources and subcontractors, the preparation of a comprehensive final report, securing cost-share dollars, and planning and executing project status meetings.

**Engineering and Design:** This task will focus on the engineering and design of the bottom ash grinding, the FGD processing facilities, and the integration into plant operation. Barr Engineering Co has completed the development of the design for the FGD process and will utilize this design to complete construction and begin processing the FGD materials. EcoMaterials Technology Inc has recently completed a bottom ash grinding facility in Texas and will be able to reference this success through the development of this site to begin marketing the product into the commercial marketplace.

**Anticipated Results:** The project results will support the mission of the CSEA to develop and deploy large-scale commercial projects that reduce environmental impacts and increase the sustainability of energy production. Results will support advancement of the current state of the art technologies to include 1) oxidization of FGD material to industry specifications, 2) the grinding of bottom ash material to industry specifications, 3) elimination of the need to dispose of large amounts of lignite coal combustion materials in solid waste facilities and 4) reduction of carbon dioxide in concrete and other products. Deliverables will include a detailed design basis and on-site equipment that would result in the

production of products deliverable to the market for consumption in the region, growing and diversifying the state's economy.

**Facilities:** The project experts anticipate footprints of 7.5 to 8 acres for these facilities to process the coal ash products for beneficial application. Bottom ash handling will consist of dewatering the product and grinding the ash to combine with other coal ash products for market. This will require multiple siloes, heat, and a mill to create a marketable product that can be beneficial. FGD will be processed in a processing building of vacuum belts through oxidization resulting in a product prepared to bring into a market that requires an additional step of processing to be a wallboard or agricultural beneficial products. Partners for these processes are Barr Engineering to complete the FGD processing with specific application to the Coal Creek FGD stream and EcoMaterials as the marketing partner for these products.

**Resources:** A team of industry experts will perform all project activities with Rainbow Energy Center overseeing the project in its entirety. For over 25 years, EcoMaterials Technology Inc has successfully marketed Coal Creek Station's coal ash products into markets across the US. EcoMaterials and their subsidiary, Synmat, have expertise in marketing all products that are expected to be produced with these additional technologies. Barr Engineering Co has dedicated resources into specifically researching Coal Creek Station's FGD stream to develop a process that will be site specific for the material produced. Barr Engineering has over 55 years of experience working in various plant sites in the area and has historical expertise working at Coal Creek Station since the commissioning of the units into commercial operation. The engineering and scientific research staff is equipped with state-of-the-art analytical, modeling, and engineering facilities to address a wide variety of energy, environmental, and mineral resource research topics. Both EcoMaterials Technology, Inc. and Barr Engineering Co. are committed to providing all necessary personnel and resources to ensure the timely completion of all activities outlined in this proposal. Industry sponsor and future plant owner Rainbow Energy Center will provide additional project advisory services. EcoMaterials and Barr Engineering have been a part of project teams that have executed similar project scopes of work focused on North Dakota utilities and bring experience gained from design and construction multiple other facilities that are similar to these proposed for Rainbow Energy Center.

**Techniques to Be Used, Their Availability, and Capability:** The foundation of the techniques to be used for these processes is one that many other utilities have utilized to handle their coal ash materials. The intention is to tie multiple technologies together and create a beneficial use of the products to create and grow a revenue stream.

The Bottom Ash facility will consist of a dewatering area as well as a pulverizer that grinds the material into a usable size that is consistent with our currently marketed fly ash. Once that material passes through the pulverizer, it will be blended with the fly ash and marketed to end users. Once the project is complete and the site is operational, it will be running as an ongoing process for our site. It will be able to process and blend 350k tons of bottom ash that REC has identified as a maximum in the previous 5 years.

The FGD processing facility will be made up of a process that will dry the FGD material and process it through oxidization and vacuum filtering techniques. There are multiple markets that can be impacted by this production process as a beneficial use. These markets consist of agricultural uses, wallboard

production, and cement intergrind. The expectations for this FGD end-product will depend on the process chosen given the markets and costs associated with achieving required specifications for each operation. An estimation of 165k tons of FGD material has been identified as the capacity for this facility based on the current operational production at Coal Creek Station.

**Environmental and Economic Impacts While Project Is under Way:** The proposed projects will require new environmental permits as well as the modification of existing environmental permits from the North Dakota Department of Environmental Quality. These projects will not affect any existing or partner facilities.

**Ultimate Technological and Economic Impacts:** The lignite-fired power plants in ND present an opportunity to economically demonstrate the utilization of Coal Ash while reducing environmental impacts. The economic health of the central region of North Dakota is tied to energy jobs in the area. Currently, the lignite industry directly employs 3623 people, with another 9500 indirect employees supported by the industry, accounting for over \$5.4 billion in economic impact. Technology advances that continue the responsible use of lignite and bring new industries to the region are critically needed to sustain and grow these jobs. This project provides a basis to market coal ash materials. It is a large-scale commercial project that will reduce environmental impacts and increase sustainability of energy production and delivery.

**Why the Project Is Needed:** The management of coal combustion residuals is a priority for Coal Creek Station. Conversations with regulators at the state and federal levels have resulted in an even deeper look into options for beneficial uses of lignite coal combustion residuals. As the concrete market continually calls for more fly ash, already currently utilized for beneficial use in concrete, it was determined that Coal Creek Station's bottom ash could be utilized and sold in the same market as it's fly ash. Market specifications require the material to be dried and ground to qualify for beneficial use in the concrete market, as is requested in this proposal.

FGD material at Coal Creek Station is currently disposed of in a coal combustion residuals solid waste facility regulated by both the state of North Dakota's Department of Environmental Quality (DEQ) and the United States Environmental Protection Agency (EPA). If oxidized and dried, this material could qualify for beneficial use in several ways as gypsum. The EPA released a study in 2023 qualifying this oxidized and dried FGD material for beneficial use on agricultural lands. Industry spec gypsum can also be used in wallboard and cement. In order for proper oxidation and drying to occur, special equipment is needed, and the cost of that equipment is included in this proposal.

The beneficial use of fly ash, bottom ash, and FGD as gypsum reduces carbon dioxide (CO<sub>2</sub>) emissions as they replace other products currently on the market that produce CO<sub>2</sub> emissions while being created and processed. Beneficial use also reduces the amount of material that needs to be disposed of in landfills decreasing environmental impact and footprints.

This project is set up for success, as it is driven by three major forces: markets, economics and environmental improvements. Markets continually demand additional ash for use in concrete, and the bottom ash will qualify as high-quality spec material to be included in that product. The business case for these sales continue to be strong, and Rainbow Energy Center is excited to partner with Eco Material Technologies to further penetrate that market. Eco Material Technologies will also play a large role in marketing the gypsum material once it is converted so that it can be used for agricultural purposes, wallboard creation or to further enhance concrete materials. Beneficial use of these materials has environmental benefits to improve the sustainability of our day to day life. The longevity of a project of

this size is immense, as this project will drastically reduce the need for permanent storage and disposal of coal combustion residuals.

The new drying and grinding facilities will produce high-grade materials, enhancing the byproduct markets and adding value to North Dakota through growing and diversifying the state's economy. By seeking a way to use these materials in a beneficial way, Coal Creek Station will be able to continue to utilize lignite to create electricity in a carbon-constrained world. This project supports the core mission of the CSEA to develop large-scale commercial projects which reduce environmental impacts and increase sustainability of energy production and delivery.

## **STANDARDS OF SUCCESS**

This project accelerates environmental stewardship and the enhancement of carbon management at Coal Creek Station. The pathway for success for Coal Creek Station has been outlined through projects such as carbon capture technology and integration of renewables into the electricity production mix. Enhancing this vision by promoting beneficial use of materials previously disposed of is yet another example of the environmental excellence we strive for at Coal Creek Station. Reducing our carbon footprint helps the state of North Dakota get one step closer to achieving their goal of carbon neutrality by 2030. Taking the steps needed to add beneficial use of our products not only extends the life of Coal Creek Station, it enhances and diversifies North Dakota's economy in a way all citizens benefit from. This creation of jobs, both direct and indirect, also helps the local communities and economy remain strong.

## BACKGROUND/QUALIFICATIONS

Rainbow Energy Center (REC) plans to dewater the solids generated by the Coal Creek Station Units 1&2 flue gas desulfurization (FGD) system. The FGD bleed stream solids are mostly calcium sulfite. The FGD will be sent to a new facility that will oxidize (inject air) to produce calcium sulfate or better known as Gypsum. The process entails oxidizing the FGD slurry in a series of large tanks. Once the oxidation occurs that material stream will go to a series of vacuum belts that will dewater the material to 15% moisture. The gypsum will then be loaded onto trucks or railcars to send out to market. Approximately 175,000 tons of gypsum will be produced each year.

Rainbow Energy Center plans to grind the solids generated by the Coal Creek Station Units 1&2 boiler bottom ash (BA) system. Conveyance of the BA will remain the same by sluicing it to a dewatering area. Once in the dewatering area the BA will be piled to dewater and transported by large haul trucks to a new processing system. BA will be pulverized and blended with our current flyash stream. The final blended product will then be loaded onto trucks or railcars to send out to market. Approximately 300,000 tons of BA will be processed each year.

**Project Team:** Rainbow Energy Center will serve as the lead organization for this project. Dwayne Rhodes, Doug Rhodes, and Jim Glass with EcoMaterials Technologies Inc will focus on the continued marketing and sales of the bottom ash and fly ash into their existing markets, as well as introduce the sale of gypsum into the market.

Rainbow Energy Center is committed to executing a fully commercialized operation to optimize the beneficial use of both bottom ash material and flue gas desulfurization (FGD) materials at Coal Creek Station. Key personnel from Rainbow Energy include Stacy Tschider (President), Jeff Jonson (Executive Vice President), Chris Faul (VP Operations), Lyndsey Roemmich (VP Finance), Jackie Fleck (Director of Business Development) Jessica Bell (Director of Government Relations & Public Affairs), Jon Price (Special Projects Manager) and John Bauer (current Plant Manager).



## MANAGEMENT

REC is the lead organization for this project and will oversee all tasks and management activities associated with this project. REC will schedule regular internal and external meetings with project staff and advisors to ensure that the project is conducted using acceptable scientific methodologies and practices in accordance with the project plan (budget, schedule, deliverables, and milestones) and is meeting quality objectives. EcoMaterials Technology, Inc. in conjunction with their subsidiary Synmat, will research and develop the market for these products and identify additional infrastructure that may be needed to support logistical aspects of marketing these products. EcoMaterials Technology, Inc. will also use their previous experience from developing and completing their project to operation in order to complete the bottom ash processing facility. Barr Engineering Co. will be the developing engineer for the FGD processing facility and work with REC to complete the FGD processing to operation.

Once the project is initiated, the project team will engage in weekly conference calls to review project status and future directions. Quarterly reports will be prepared and submitted to project sponsors for review. Regular meetings will be held to review the status and results of the project and discuss directions for future work. A broad team approach is key to successful execution of this project.

Project progress will be measured by completion of milestones and deliverables as noted in the project timeline in Figures 1 and 2. The milestones and deliverables are at key times during the project design, permitting, and costing components of the project. The deliverables are indicated where key design documents and reports are noted, while the milestones are noted as key accomplishments during the project's progress.

## TIMETABLE

The project timeline can be found in Figures 1 and 2. The combination of both projects is scheduled for 30 months, with a projected start date of May 2023. The start date may depend on procurement of the Coal Creek Station by Rainbow Energy Center. This timeline is necessary to maintain a schedule that could allow for operation to begin by October 2025.

➔	▲ Engineering	215 days	Tue 5/9/23	Mon 3/4/24
➔	▷ Design Engineering	170 days	Tue 5/9/23	Mon 1/1/24
➔	▷ Permitting	160 days	Tue 7/25/23	Mon 3/4/24
➔	▲ Procurement	245 days	Tue 6/6/23	Mon 5/13/24
➔	Grinding Mill	44 wks	Tue 6/6/23	Mon 4/8/24
➔	Raw Ash Building	28 wks	Tue 8/15/23	Mon 2/26/24
➔	Switchgear	45 wks	Tue 7/4/23	Mon 5/13/24
➔	1500 ton silos	34 wks	Tue 9/5/23	Mon 4/29/24
➔	1000 ton silos	30 wks	Tue 9/5/23	Mon 4/1/24
➔	500 ton silo	30 wks	Tue 9/5/23	Mon 4/1/24
➔	▲ Implementation	461 days	Mon 5/1/23	Mon 2/3/25
➔	▷ Civil	271 days	Mon 5/1/23	Mon 5/13/24
➔	▷ Mechanical	255 days	Tue 10/24/23	Mon 10/14/24
➔	Electrical	35 wks	Tue 6/4/24	Mon 2/3/25
➔	Dry commissioning	6 wks	Tue 2/4/25	Mon 3/17/25
➔	Process commissioning	4 wks	Tue 3/18/25	Mon 4/14/25
➔	Turnover to Operations	1 day?	Tue 4/15/25	Tue 4/15/25
➔	Punchlist Items	7 wks	Tue 4/15/25	Mon 6/2/25
➔	Final Completion	0 days	Mon 6/2/25	Mon 6/2/25

Figure 1. Bottom Ash Project Gantt chart.

Task Name	Duration	Start	Finish
<b>Coal Creek Station - FGD Dewatering</b>	<b>220 wks</b>	<b>Thu 7/15/21 8:00 AM</b>	<b>Wed 10/1/25 5:00 PM</b>
<b>Phase 1 - Preliminary Engineering</b>	<b>89.4 wks</b>	<b>Thu 7/15/21 8:00 AM</b>	<b>Sat 4/1/23 8:00 AM</b>
Project Kick-off and Preliminary Engineering	6 wks	Fri 7/15/22 8:00 AM	Thu 8/25/22 5:00 PM
Prepare Design Basis Document (includes BoD, GA, PFD, prelim eqpt list)	12.6 wks	Fri 8/26/22 8:00 AM	Tue 11/22/22 5:00 PM
Submit Design Basis to client for review	18.6 wks	Mon 10/17/22 8:00 AM	Wed 2/22/23 5:00 PM
<b>Phase 2 - Detailed Engineering</b>	<b>57.8 wks</b>	<b>Thu 3/2/23 8:00 AM</b>	<b>Tue 4/9/24 5:00 PM</b>
Preliminary design: Oxidation sys; Dewatering sys; WW treatment; Major BOP	39.4 wks	Wed 3/15/23 8:00 AM	Thu 12/14/23 5:00 PM
Prepare oxidation & dewatering equipment RFP	11.8 wks	Wed 3/15/23 8:00 AM	Mon 6/5/23 5:00 PM
B&W engineering study, preliminary design	21.6 wks	Wed 3/15/23 8:00 AM	Fri 8/11/23 5:00 PM
Prepare other major equipment specifications	15.2 wks	Fri 8/11/23 5:00 PM	Mon 11/27/23 5:00 PM
<b>Detailed Design</b>	<b>90.4 wks</b>	<b>Mon 7/18/22 8:00 AM</b>	<b>Tue 4/9/24 5:00 PM</b>
Civil Site	6 wks	Mon 7/18/22 8:00 AM	Fri 8/26/22 5:00 PM
Geotechnical	27.4 wks	Mon 8/22/22 8:00 AM	Wed 3/1/23 8:00 AM
<b>Phase 3 - Construction</b>	<b>90.6 wks</b>	<b>Mon 1/8/24 8:00 AM</b>	<b>Wed 10/1/25 5:00 PM</b>
Procurement	66.2 wks	Mon 1/8/24 5:00 PM	Tue 4/15/25 5:00 PM
Major equipment procurement (transformer critical path)	66.4 wks	Mon 1/8/24 8:00 AM	Tue 4/15/25 5:00 PM
Startup and commissioning	10.6 wks	Mon 7/21/25 8:00 AM	Wed 10/1/25 5:00 PM

Figure 2. FGD Project Gantt chart.

## BUDGET

The proposed budget is \$85,000,000, with \$42,500,000 loan from NDIC and \$42,500,000 cash from Rainbow Energy Center. The budget includes all engineering, equipment, building materials, construction, and commissioning of the facilities. The detailed breakdown is shown in Table 1. The budget notes can be found in Appendix G.

<b>Table 1. Estimated Capital Costs</b>				
<b>Project Associated Expense</b>	<b>NDIC Grant</b>	<b>NDIC Loan</b>	<b>Rainbow Energy Center Share (Cash)</b>	<b>Total Project</b>
<b>Mobilization, demolition, and sitework</b>	\$ -	\$ 999,146	\$ 999,146	\$ 1,998,291
<b>Foundations and concrete</b>	-	719,255	719,255	1,438,509
<b>Engineering</b>	-	105,000	105,000	210,000
<b>Equipment</b>		-	-	-
Mechanical	-	10,497,307	10,497,307	20,994,614
Electrical	-	2,992,633	2,992,633	5,985,265
Storage	-	2,087,500	2,087,500	4,175,000
Material Handling	-	1,428,901	1,428,901	2,857,802
Process	-	3,795,608	3,795,608	7,591,217
Other	-	294,500	294,500	589,000
<b>Architecture, steel and building</b>	-	4,128,184	4,128,184	8,256,369
<b>Construction</b>	-	-	-	-
Structural	-	2,855,500	2,855,500	5,711,000
Mechanical	-	2,950,830	2,950,830	5,901,659
Electrical	-	2,800,000	2,800,000	5,600,000
Other	-	834,594	834,594	1,669,188
<b>Commissioning</b>	-	606,127	606,127	1,212,255
<b>Indirect costs</b>	-	5,404,915	5,404,915	10,809,831
<b>Total Project Costs</b>	\$ -	\$ 42,500,000	\$ 42,500,000	\$ 85,000,000

## **TAX LIABILITY**

Neither Rainbow Energy Center nor its parent company, REMC Assets, LP, have an outstanding tax liability owed to the State of North Dakota or any of its political subdivisions.

Submitted by: WellSpring Hydro  
 Project Duration: 26 months  
 Total Project Costs: \$250,886,700  
 Request for: \$5,000,000 grant, \$50,000,000 loan

**Summary of Project:** This project supports the extraction of elements from oilfield produced water to manufacture industrial commodities, including lithium, caustic soda, hydrochloric acid, calcium chloride, and chlor-alkali products.

### Technical Review Results

Overall Technically Sound (222/315)	
Good	1
Fair	
Questionable	

### BND Economic Feasibility Recommendation

Overall Economic Feasibility	
Yes	X
No	

### Technical Committee Scores

	Score (Out of 50)
Charlie Gorecki	Abstain
Josh Teigen	36
Dave Glatt	37
Lynn Helms	38
Justin Kringstad	35
Rachel Retterath	41
Todd Steinwand	40
John Weeda	42

Average: 38

**Recommendation: 8-0 Consider funding**

# TECHNICAL REVIEWERS' RATING SUMMARY

## C-04-G

Unlocking the Full Potential of Produced Water

Submitted By: WellSpring Hydro

Date of Application: May 2023

**Request for \$5,000,000 Grant, \$50,000,000 Loan**

**Total Project Costs \$250,886,700**

Technical Reviewer

**G3**

Rating Category	Weighting Factor	Rating	Weighted Score
1. Objectives	3	4	12
2. Impact	9	5	45
3. Methodology	9	2	18
4. Facilities	3	3	9
5. Budget	9	3	27
6. Partnerships	9	4	36
7. Awareness	3	3	9
8. Contribution	6	5	30
9. Project Management	6	3	18
10. Background	6	3	18
315		222	222

**OVERALL TECHNICALLY SOUND**

GOOD (IF > 214)

FAIR (200-213)

QUESTIONABLE (IF < 200)

Diversification Delivery:	Yes	No
Project enhances the production of clean sustainable energy, to make the State a world leader in the production of clean sustainable energy, and/or to diversify and grow the State's economy.	✓	
Commercialization or Development/Expansion:	Yes	No
Concept will lead to the <b>large-scale development and commercialization</b> of projects, processes, activities, and technologies that reduce environmental impacts and/or increase sustainability of energy production and delivery.	✓	

In State Requirement:	Yes	No
The funds distributed from the financial assistance are to be applied to support in-state activities and must have other sources of financial support.	✓	

- The objectives or goals of the proposed project with respect to clarity and consistency with Clean Sustainable Clean Energy Authority goals of projects, processes, activities, and technologies that reduce environmental impacts and increase sustainability of energy production and delivery are: 1 – very unclear; 2 – unclear; 3 – clear; 4 – very clear; or 5 – exceptionally clear.**

**Reviewer G3 (Rating 4)**

While some aspects are vague and still in testing phase, the objectives and goals are clearly stated. Whether they are attainable is less clear. The extraction of lithium is currently a key factor in future energy production.

- The objectives will make a difference in the near term to the state’s economy: 1 – no impact; 2 – small impact; 3 – likely impact; 4 – most likely impact; or 5 – significant impact.**

**Reviewer G3 (Rating 5)**

If obtainable, the objectives will have a significant impact. Lithium is a key factor in battery production. This could potentially provide not only jobs and tax revenue associated with the extraction, but open North Dakota as a location for battery production.

- The quality and clarity of the methodology in the proposal is: 1 – well below average; 2 – below average; 3 – average; 4 – above average; or 5 – well above average.**

**Reviewer G3 (Rating 2)**

While the goals and objectives are clear, the methodology is not. How will field testing be conducted? How will they get produced water to the facility? How does the process work? They have not stated a fallback position if field tests do not go as anticipated.

- The facilities and equipment available and to be purchased for the proposed pilot or commercialization strategy is: 1 – very inadequate; 2 – inadequate; 3 – adequate; 4 – notably good; or 5 – exceptionally good.**

**Reviewer G3 (Rating 3)**

They clearly state that the equipment they need is available, however supply chain questions exist. They reference a SWD well, which is a Class II well. They will actually need a Class I injection well.

- The proposed budget is comprehensive and sufficient relative to the outlined work and the timetable: 1 – not sufficient; 2 – possibly sufficient; 3 – likely sufficient; 4 – most likely sufficient; or 5 – certainly sufficient.**



**Reviewer G3 (Rating 3)**

The evaluation of this budget is beyond this reviewer's expertise.

- 6. The appropriate strategic partnerships are in place for short and long term plans to be successful: 1 – very limited; 2 – limited; 3 – adequate; 4 – better than average; or 5 – exceptional.**

**Reviewer G3 (Rating 4)**

Manufacturing and development partners are clearly identified and appear to be very good. Environmental partnerships are vague.

- 7. The likelihood that the project approach (time & budget) will achieve its technical and market goals is: 1 – not achievable; 2 – possibly achievable; 3 – likely achievable; 4 – most likely achievable; or 5 – certainly achievable.**

**Reviewer G3 (Rating 3)**

The process sounds promising though there are still many unknowns. The need for a Class I injection well will increase permitting time, however it still should be achievable within the 2-year timeframe.

- 8. The scientific and/or technical contribution of the proposed work to specifically address Clean Sustainable Energy Authority goals of impacting technology used in North Dakota's energy industries will likely be: 1 – extremely small; 2 – small; 3 – significant; 4 – very significant; or 5 – extremely significant.**

**Reviewer G3 (Rating 5)**

If successful, the scientific and technical contributions will be highly significant, not only to the state, but worldwide. This could reduce, if not eliminate, our dependence on China for lithium.

- 9. The project management plan, including budgeting projections, partner connections and well-defined milestone chart is: 1 – very inadequate; 2 – inadequate; 3 – adequate; 4 – notably good; or 5 – exceptionally good.**

**Reviewer G3 (Rating 3)**

Partnering and milestones are very well defined. There are questions on whether the milestones are achievable, but they are defined. There is not a contingency plan if milestones are not met.

- 10. The background and experience of the project principals with regards to technical qualifications and competence is: 1 – very limited; 2 – limited; 3 – adequate; 4 – better than average; or 5 – exceptional.**

**Reviewer G3 (Rating 3)**

Since this is the first of its kind operation, it is difficult to judge qualifications.

---

**Section C. Overall Comments and Recommendations:**

**Please comment in a general way about the merits and flaws of the proposed project and make a recommendation whether or not the project is technically sound.**

**Reviewer G3**

The significance of lithium extraction cannot be overstated. The most glaring deficiencies are vague methodology and incomplete environmental discussions. While stormwater is discussed, there is no mention on groundwater protection or a plan for a potential produced water spill (nor its handling) on a potential lithium spill. They state zero emissions but do not say how this is achieved. This will require a Class I injection well rather than a Class II well.

May 19, 2023



North Dakota Industrial Commission  
State Capitol – Fourteenth Floor  
600 East Boulevard Avenue  
Bismarck, ND 58505

**Re: Project titled “Unlocking the Full Potential of Produced Water as a Key Component of Clean Sustainable Energy”**

To NDIC & Clean Sustainable Energy Authority Program:

Triple 8 LLC dba Wellspring Hydro (WH) is submitting this application for grant and loan funds under the North Dakota Industrial Commission Clean Sustainable Energy Authority Program. This project initiates the commercialization of a business plan submitted in an earlier NDIC CSEA grant in December 2021, that supported the completion of FEL-3 engineering and design.

Wellspring Hydro will utilize a unique feedstock from oilfield brines (a.k.a. produced water) that presently is treated and pumped into disposal wells. Wellspring Hydro’s project will produce three commercially essential products (and lithium extraction) in a sustainable format that will diversify North Dakota’s economy, bolster existing industries with an improved cost position, and drive clean sustainable energy.

Wellspring Hydro, a North Dakota company, is at Financial Investment Decision (FID) to execute a strategy to commercialization of an estimated \$250 million dollar treatment facility. When completed this business will:

1. create 53 new full-time jobs and 200+ local contractors to build.
2. generate new local products and tax revenues for North Dakota.
3. enhance North Dakota’s economic diversity, sustainable energy, and environmental outlook.
4. create feedstocks from other valuable materials in the future, including lithium.

We are requesting \$5,000,000 in grant funds and \$50,000,000 in loan funds from the Clean Sustainable Energy Authority Program of the North Dakota Industrial Commission. In return, Triple 8 LLC commits to matching the funds and remaining capital with equity investment.

If you have any questions or require additional information, please do not hesitate to contact Mark Watson 281-813-6735 or [mark@wellspringhydro.com](mailto:mark@wellspringhydro.com).

Mark Watson  
CEO  
Wellspring Hydro

## APPLICATION CHECKLIST

*Use this checklist as a tool to ensure that you have all of the components of the application package. Please note, this checklist is for your use only and does not need to be included in the package.*

<input checked="" type="checkbox"/>	Application
<input checked="" type="checkbox"/>	Transmittal Letter (Included in Application)
<input checked="" type="checkbox"/>	Tax Liability Statement (Appendix)
<input checked="" type="checkbox"/>	Letters of Support (Appendix)
<input checked="" type="checkbox"/>	Confidentiality Request (Attached)
<input checked="" type="checkbox"/>	Business Plan (Attached)
<input checked="" type="checkbox"/>	Historical Financial Statements (3 years Included in Business Plan)
<input checked="" type="checkbox"/>	Budgeted Projections (Included in Business Plan)
<input checked="" type="checkbox"/>	Loan/Loan Guarantee Application (Attached)
<input type="checkbox"/>	Other Appendices (If Applicable)

When the package is completed, send an electronic version to [sustainableenergy@nd.gov](mailto:sustainableenergy@nd.gov) and 2 hard copies by mail to:

Clean Sustainable Energy Authority  
North Dakota Industrial Commission  
State Capitol – 14<sup>th</sup> Floor  
600 East Boulevard Ave Dept 405  
Bismarck, ND 58505-0840

For more information on the application process please visit:  
<http://www.nd.gov/ndic/csea-infopage.htm>

Questions can be addressed to Al Anderson (701) 595-9668.

Clean Sustainable Energy Authority  

---

North Dakota Industrial Commission

## Application

**Project Title: Unlocking the Full Potential of Produced Water as a Key Component of Clean Sustainable Energy**

**Applicant: Mark Watson**

**Date of Application: May 18, 2023**

**Amount of Request**

**Grant: \$5,000,000 USD**

**Loan: \$50,000,000 USD**

**Total Amount of Proposed Project:  
\$250,886,700 USD**

**Duration of Project: 26 Months**

**Point of Contact (POC): Mark Watson**

**POC Telephone: (281) 813-6735**

**POC Email: mark@wellspringhydro.com**

**POC Address: 4828 Highway 85 Williston, ND  
58801**

## TABLE OF CONTENTS

*Please use this table to fill in the correct corresponding page number.*

<b>Abstract</b>	<b>5</b>
<b>Project Description</b>	<b>10</b>
<b>Standards of Success</b>	<b>20</b>
<b>Background/Qualifications</b>	<b>25</b>
<b>Management</b>	<b>27</b>
<b>Timetable</b>	<b>30</b>
<b>Budget</b>	<b>31</b>
<b>Confidential Information</b>	<b>32</b>
<b>Patents/Rights to Technical Data</b>	<b>33</b>
<b>State Programs and Incentives</b>	<b>34</b>
<b>APPENDIX</b>	<b>35</b>
<b>Tax Liability Statement</b>	<b>36</b>
<b>Primary Sector Certification</b>	<b>37</b>
<b>Letter of Support – City of Williston 1</b>	<b>38</b>
<b>Letter of Support - City of Williston 2</b>	<b>39</b>
<b>Letter of Support - UND</b>	<b>40</b>
<b>Letter of Support - Commerce</b>	<b>41</b>
<b>Letter of Support - Pivotal</b>	<b>42</b>
<b>Letter of Support - OneCor</b>	<b>43</b>
<b>Letter of Support - Cerilon</b>	<b>44</b>

## ABSTRACT

### Background:

Wellspring Hydro is a locally founded North Dakota company with a mission to unlock the full potential of produced water as a feedstock for sustainable, clean energy. Wellspring Hydro is requesting financial support for commercialization of an innovative solution that will diversify the state's economy through an environmental solution. The Wellspring Hydro process is based on combining proven technologies in a novel way to develop products from various renewable components, including produced water waste stream as the key feedstock.

Wellspring Hydro's project will produce commercially essential commodity products in the State of North Dakota in a sustainable format that will diversify the economy, bolster existing industries (clean sustainable energy), and operate with a vision of zero waste or harmful emissions.

Wellspring Hydro was awarded a \$1 M grant from the Clean Sustainable Energy Authority (CSEA) in December 2021 focused on the execution of the FEL-3 engineering and design study to position for commercialization. Wellspring hydro is in the final steps to complete this critical stage before Financial Investment Decision (FID) by utilizing these grant funds, an equity match from Hargrove Engineers and other private equity investment. The FEL 3 engineering study (led by Hargrove Engineers and Constructors) was completed in May 2023, with final cost estimates expected to be completed by June 2023. The purpose of the FEL 3 study was to provide a +/- 10% estimate for a 150 ton per day chlor-alkali plant to be located outside of Williston, ND.

The overall salt recovery process design has been validated through four independent bench-scale testing performed in 2021, 2022 and 2023. The quality of salt contained in North Dakota's geology has proven to be of high quality, more than adequate for chlor-alkali use. The salt in North Dakota is only second to Chilean Salt which is considered by many to be the Gold Standard. Due to the quality and significant quantity of salt in North Dakota, Wellspring Hydro has the technical feasibility of success to progress the project.

Wellspring Hydro's cost to build and install a new greenfield 150 STPD membrane plant in Williston, North Dakota, is \$250 million. With an IRR of 21%- and 5-year payback, this project on its own merits is a crucial investment for the state of North Dakota, aligned with the intent of the Clean Sustainable Energy Authority's mission.

## Objectives:

Finalize, execute, and deliver.

	Key Deliverables	Funds	Results
1	<b>Field Validation – Technology and Commercial</b>	\$4.0 M	The critical objective is to demonstrate technical viability in the field (in multiple stages and scopes), to receive the commercial assurances provided by performance guarantees from technology providers.
2	<b>Initial Detail Design</b>	\$6.0 M	The critical objective is the completion of Initial Detailed Design to finalize technology vendors and identify the procurement of specialized technology and long-lead items as a prerequisite for objective 3.
3	<b>Procurement of Specialized Equipment</b>	\$100.0 M	The critical objective is to secure specialized and long-lead item equipment to meet overall timeline. The objective will require early funds to complete “Issue for Purchase” (IFP) technical packages with vendors and make initial downpayments on equipment.
4	<b>Detailed Engineering Plan</b>	\$8.5 M	The critical objective is to continue detailed engineering in parallel to early construction in preparation for equipment installation and process start-up.
5	<b>Construction &amp; Plant Start-up</b>	\$ 131.5 M	The critical objective is to execute engineering plans of all construction activities required from onsite mobilization through construction completion and pre-commissioning for a seamless implementation of the full-scale facility.

- Indicates Grant Funds
- Indicates Loan Funds



**Expected Results:**

The primary result is to complete the construction and start-up of the Wellspring Hydro Chlor-alkali facility by Q4 2025.

Key Deliverables	Results
<p><b>Validation of Technology in the Field</b></p>	<p>Technology validation of a field trial designed to create high-quality salt from Bakken produced water based on the proposed Wellspring Hydro process. This will yield performance guarantees with the technology provider and final assurances in the proposed process.</p>
<p><b>Lithium Extraction</b></p>	<p>As a component of the field trial process and Initial Detailed Design, Wellspring Hydro will be able to develop the lithium extraction process of the “mother liquor” stream. There are multiple technology providers that have completed initial feasibility and will progress to Equipment proposals.</p>
<p><b>Production of High Value Commodity Products</b></p>	<p>Wellspring Hydro’s project will produce commercially essential commodity products Caustic Soda and Hydrochloric Acid. Both products have current demand in industrial and energy sectors and future demand in the support of clean sustainable energy (Carbon Capture, Oil &amp; Gas production, and lithium extraction).</p>
<p><b>Sustainable Use of Produced Water Waste</b></p>	<p>40+% reduction in produced water that enters the plant will be realized, along with the creation of all process fresh water needs from the treated condensate stream off the crystallizer. Value is created from what is currently wasted.</p>
<p><b>Financial Impact</b></p>	<p>The business is projected to have a year one of \$82.6 M revenue and support fifty-three full-time employees. The current unleveraged financial returns yield a 21.7% IRR and \$170.0 M NPV. Year 1 EBIDTA is expected to be \$54.0 M with steady performance within +/- 5% consistency through year 5 EBIDTA at \$53.8 M. The full-rate state tax on product sales is expected to be ~\$5.5 M per year.</p>

 Indicates Grant Funds

 Indicates Loan Funds

**Duration:**

The detailed design, construction and start-up is expected to take 24-26 months after the Financial Investment Decision, planned for September 2023.

**Critical Milestones**

Milestone	Milestone Date
FEL-3/DD Kick-off Meeting	15 Feb 23
FEL-3 Complete	15 Jun 23
Financial Investment Decision (FID)	01 Sep 23
Field Validation – Technology and Commercial	01 Nov 23
Initial Detailed Design	01 Dec 23
Procurement of Specialized Equipment	01 Jan 24
Detail Design Complete	23 Jun 24
Construction Mobilization	04 Jan 24
All Major Equipment	03 Oct 24
Mechanical Completion	05 Sep 25
Start-Up	31 Oct 25

Grant funds will be allocated to Field Validation – Technology and Commercial and Initial Detailed Design, expected to be completed by December 1<sup>st</sup>, 2023. The timeline for these grant deliverables is expected to be 5-6 months total from funding.

Loan funds will be allocated on procurement of specialized equipment, expected to begin immediately after funding through January 1<sup>st</sup>, 2024. The prerequisite for the procurement process is the completion of initial detailed design, led by Hargrove Engineers.

## Total Project Cost:

Capital Estimates	Cost in USD
Technical and Commercial Viability	\$4,000,000.00
Front-End Engineering & Design	\$6,000,000.00
Working Capital	\$3,694,040.00
Upfront Land & Development	\$1,506,550.00
Labor	\$17,016,249.86
Material	\$6,665,618.00
Indirect Labor/Construction Equipment	\$3,101,831.00
Subcontract	\$32,065,894.00
Material Sales Tax	\$533,250.00
Freight-Equipment	\$1,074,214.00
Contractor's Mark-Up	\$666,562.00
Process & E/I Equipment - SWD	\$8,000,000.00
Process & E/I Equipment - Front-End	\$30,000,000.00
Process & E/I Equipment - Chlor-Alkali	\$60,036,505.00
Detailed Engineering	\$8,500,000.00
Procurement & Start-up Support	\$2,675,328.00
CM Services	\$5,350,658.00
Home Office & Contingency	\$60,000,000.00
<b>Total</b>	<b>\$250,886,700</b>

 Indicates Grant Funds

 Indicates Loan Funds

**Participants:** Identified partners for execution of Grant and Loan request. Additional partner information is available in the Business Plan, and specific technology partners are outlined in resources.

- Wellspring Hydro – Management Team - Williston, ND
- Hargrove Engineers & Constructors – Birmingham, AL
- Tormod Operators – Birmingham, AL
- Mastec Infrastructure - Coral Gables, FL
- FCI Constructors – Denver, CO
- InDemand – Bismarck, ND
- Produced Water Partner(s)
- Salt Crystallizer Partner(s)
- Lithium Extraction Partner(s)

## PROJECT DESCRIPTION

### Objectives:

Wellspring Hydro (WSH) intends to build a modern chlor-alkali plant in Williston, North Dakota which will use crystallized sodium chloride salt deriving from the Williston Basin oilfield brine (i.e., produced water); creating high quality sodium chloride salt and water from an oilfield waste stream to feed a chlor-alkali process will be a first of its kind.

Wellspring Hydro's cost to build and install a new greenfield 150 STPD membrane plant in Williston, North Dakota, is \$250 million.

Finalize, execute, and deliver.

1. Field Validation – Technology and Commercial
  - a. Wellspring Hydro will complete final technical and commercial viability of the front-end process through field trial demonstrations in parallel with detailed design. This process has been validated through four independent bench-scale tests performed in 2021, 2022 and 2023. Commercial viability will require the selected technology in the field to align with vendor processes to provide performance guarantees for the required specifications.
  - b. The critical objective is to demonstrate technical viability in the field (in multiple stages and scopes), to receive the commercial assurances provided by performance guarantees from technology providers. This will include final salt crystallization bids with multiple vendors, who have completed technical evaluations.
  - c. Further development and confirmation testing with Lithium partner to focus on mother liquor lithium extraction of up to two hundred tons per year.
2. Initial Detailed Design
  - a. From the Financial Investment Decision (FID), Wellspring Hydro will begin Front-End Engineering Design with Hargrove to perform the detailed engineering sufficient to produce procurement and construction documents for the supply of fabrication, construction installation, materials and equipment and the full construction and start-up of the plant.
  - b. The critical objective is the completion of Initial Detailed Design to finalize technology vendors and identify the procurement of specialized technology and long-lead items as a prerequisite for objective 3.
3. Procurement of Specialized and Long-lead Equipment
  - a. Hargrove and Associates Purchasing Department will provide procurement support services for the Project. Hargrove will be responsible for the procurement of all major equipment, minor equipment, tagged instruments, fabricated materials.
  - b. As a part of FEL-3 process, Wellspring Hydro and Hargrove have identified a bidder list, completed technical packages an Engineering Requisition Worksheet (ERW) for engineered equipment and issued Requests for Quotation (RFQ). The bids have been received and analyzed for technical and commercial consideration. These costs are utilized in the final cost estimate for FEL-3.

- c. The critical objective is to award specialized and long-lead item equipment to meet overall timeline. The objective will require early funds to complete “Issue for Purchase” (IFP) technical packages with vendors and make initial downpayments on equipment.
4. Detailed Engineering Plan
    - a. Following Initial Detailed Design phase and in parallel of the procurement plan, Hargrove will continue to provide engineering services as required by the construction work to clarify or revise the engineering documents provided for the construction of the project. Hargrove will provide information requested to assist the contractors in the construction of the project and the coordination of their activities, including 3-D Model review assistance at the site.
    - b. Detailed discipline engineering will continue for 10 months post FEED Phase and to achieve the engineering construction release dates.
    - c. The critical objective is to continue detailed engineering in parallel to early construction in preparation for equipment installation and process start-up.
  5. Construction & Plant Start-up
    - a. Wellspring Hydro will work with Hargrove (Engineering and Design) and Mastec (Construction Management) to formulate the contract documents for the construction contracts per the project contracting strategy. Hargrove will assist by providing technical and construction management support during the duration of project through mechanical completion.
    - b. Wellspring Hydro will formulate the Project Completion Plan and will assist with planning QA/QC functions to assure incremental acceptance of the plant and coordination with the start-up team. Wellspring Hydro will utilize Mastec to fulfill its construction obligations. Wellspring Hydro will manage all construction activities required to complete the work to the point of being ready for commissioning.
    - c. The critical objective is to execute engineering plans of all construction activities required from onsite mobilization through construction completion and pre-commissioning for a seamless implementation of the full-scale facility.

**Methodology:**

Modern Chlor-Alkali technology includes sophisticated membrane cells to split apart the NaCl molecule via electrochemical reactions. The salt and water streams fed to the membrane cells must be highly purified to operate efficiently. Hargrove Engineering has designed and managed multiple chlor-alkali plant projects and will coordinate the overall project design for the entire Wellspring Hydro facility.

1. Field Validation – Technology and Commercial
  - a. Field testing is an important progression from the successful bench scale tests to show consistency and longitudinal analysis in various stages.
  - b. The key methodology steps include:
    - i. Stage 1 – In field testing of produced water over 60-day initial scope. Key success criteria would be longitudinal analysis over time to quantify any unknown constituent in the water and selection of optimum pre-treatment chemistry.

- ii. Stage 2 – Full scale commercial trial to create salt out of produced water with mobile crystallizer of selected technology provider. Key success criteria would be to confirm ability to meet consistent high-quality salt specification, while evaluating corrosion and scale impact to equipment.
  - iii. Through field trial validation, Wellspring Hydro will finalize the process to bid on the Salt Crystallizer technology with a vendor that can meet both commercial and technical requirements to meet company and investor objectives. Based on multiple bench scale validation, the critical focus is the commercial commitments that can be offered through a field trial and performance guarantees.
  - iv. Lithium Extraction – Wellspring Hydro will qualify multiple lithium extraction vendors to select a technology partner for Detailed Design. Multiple vendors have verified their capability through bench scale results with the mother liquor output.
- 2. Initial Detailed Design
  - a. Once the Wellspring Hydro Executive Leadership has approved the project, the next step will be to commence initial detailed design in order to perform enough engineering to develop design to a point in which various quantities can be established. Each system will be assigned to a system engineer who will be responsible for the entire design of the respective system.
  - b. The key methodology steps include design criteria, P&ID's, specifications, installation details and other discipline focus areas:
    - i. A kick-off meeting for the initial detailed design phase will be held to establish the path forward for the project.
    - ii. Once the heat & material balance has been validated and process requirements confirmed, the next effort will be developing the P&IDs to approval level.
    - iii. For expediency purposes major process equipment will be committed and procured during the initial detailed design phase of the project. This will mitigate project cost risk and impact on schedule to improve the overall engineering productivity (**Highlighted in objective 3 – procurement of specialized equipment**).
    - iv. The schedule is based on a quick turnaround of the approved P&IDs to commence detail design post IFA (Issued for Approval) as early as practical and solidify the equipment layout.
- 3. Procurement of Specialized Equipment
  - a. Hargrove will provide procurement assistance services for Wellspring Hydro. Each chlor-alkali unit operation is based on proven technology supplied by experienced and respected technology suppliers.
  - b. The key methodology steps include:
    - i. Upon receipt of a Wellspring Hydro approved Award Recommendation, Hargrove will enter the proposed purchase order and issue purchase order.
    - ii. The Engineers will be responsible for revising the RFQ technical package to an "Issue for Purchase" (IFP) technical package. This represents the final agreed upon purchase specifications and will be made a part of the purchase order.

- iii. Purchase orders will require additional engineering support from vendors and require downpayments on equipment to expedite delivery schedule.
  - iv. Hargrove will expedite receipt of the vendor data from the supplier based on the Vendor Data Requirements established by the originating Engineer.
  - v. The Engineers will review and approve all vendor data for the items they originate regarding compliance with the requirements of the design.
  - vi. Hargrove will expedite delivery of the equipment and materials.
- 4. Detailed Engineering Plan
  - a. As the project progresses, Detailed Engineering will be an ongoing effort to support the installation and completion of the process. The system engineer will continue to “own” the P&ID and is responsible for the specification of all equipment, and coordination of all supporting discipline tasks necessary for the complete definition and documentation of the system. The system engineer is also responsible for the expenditure of resources (engineering manhours, budgeted dollars for materials, etc.) associated with those systems under his or her control.
  - b. The methodology of the Detailed Design will include:
    - i. Development of equipment specifications will be in parallel in certain cases with approval of P&ID’s and will commence upon client approval of all P&ID’s.
    - ii. Detailed discipline engineering continues for 10 months post FEED Phase and to achieve the engineering construction release dates procurement PO dates as listed in the estimate basis will need to be committed during this phase of the project.
- 5. Construction & Plant Start-up
  - a. Wellspring Hydro and Hargrove will formulate the contract documents for the construction contracts per the project contracting strategy. Wellspring Hydro will administer these contracts as construction manager by providing technical and construction management support during the duration of project through mechanical completion.
  - b. The basic methodology steps to execution will be in five basic phases:
    - i. “Enabling civil work”—piling, underground piping & electrical.
    - ii. “Get out of the ground:” Foundations, slabs, development.
    - iii. “Install the equipment:” Steel erection, equipment erection.
    - iv. “Bulk installation:” Piping, electrical and instrument work.
    - v. “Project completion:” Testing, checkout, turnover by system.

## Anticipated Results:

### Validation of Technology in the Field

In the first objective, Wellspring Hydro will complete final validation of a process to use crystallized sodium chloride salt deriving from the Williston Basin oilfield brine (i.e., produced water); creating high quality sodium chloride salt and water from an oilfield waste stream to feed a chlor-alkali process. The field test will be creating sodium chloride salt with Bakken produced water in the field, further validating the multiple bench scale tests completed in 2020.

- Technology validation of creating high-quality salt from Bakken produced water that will yield performance guarantees with the technology provider and final assurances in the proposed process. The output of the field trial and vendor selection will ensure that Wellspring Hydro will be positioned for commercial assurances.

### Lithium Extraction

As a component of the field trial process and Front-End Engineering & Design, Wellspring Hydro will be able to develop the lithium extraction process of the “mother liquor” stream. There are multiple technology providers that have completed initial feasibility and will progress to Equipment proposals. After Wellspring Hydro recovers salt and water from the produced water the lithium present in the produced water will be concentrated, making it a high potential feedstock to a lithium recovery process.

- Wellspring Hydro is seeking a process patent for removing salt from waste oilfield produced water which in turn concentrates the feed brine into a “mother liquor” stream. This concentrated mother liquor creates ideal feedstock as it increases the lithium by a factor of up to four times. This concentration allows for even more efficient extraction by Wellspring Hydro and its partner over the standard brine process. Due to this concentration upgrade, the potential for up to 3.5 tons of lithium extraction per week is achievable and will yield nearly 4M in accretive revenue and 91,000,000 gallons of water saved.

### Production of High Value Commodity Products

Wellspring Hydro’s project will produce commercially essential commodity products Caustic Soda and Hydrochloric Acid. Both products have current demand in industrial and energy sectors and future demand in the support of clean sustainable energy (Carbon Capture, Oil & Gas production, and lithium extraction). The primary focus of the plant will be to produce and sell caustic soda (at 50% and 25% NaOH concentration), hydrochloric acid (at 35% HCl concentration). All products are currently imported into North Dakota with limited regional production. All products will meet industry standards.

- Caustic Soda - Caustic soda will be sold locally and regionally for use in various heavy industries such as refineries, power stations, pulp mills and for carbon capture projects. Wellspring Hydro’s products, specifically caustic soda, will be consumed in local and regional sustainable-clean-energy projects and designed to capture or sequester carbon from power generation. Wellspring Hydro will be a key chemical supplier to the burgeoning CCS/CCUS (Carbon Capture and Storage/Carbon Capture, Utilization and Storage) industry in North Dakota and surrounding



states. Project Tundra at Milton R. Young station and Coal Creek Station will require substantial amounts of NaOH (caustic soda) to scrub sulfur dioxide (SO<sub>2</sub>) to zero. This need is driven by the Amine CO<sub>2</sub> removal technology employed in large scale carbon capture such as those at power stations that utilize coal with sulfur content. Currently all Caustic Soda is imported into the State at a premium. Wellspring Hydro will be able to supply all the States projected needs.

- Hydrochloric Acid - The hydrochloric acid will be sold predominately into the local and regional oil and gas industry; other consumers include food processing and steel manufacturing industries in neighboring states. In North Dakota there is a significant opportunity to develop production enhancement acidification of existing wellbores and well recompletions to maximize the Williston Basins oil output. Many current producers utilize large acid jobs to open calcium carbonate scaled perforations and liners that restrict production. These large acid production enhancement jobs are limited by cost and availability of HCl. WSH can help provide stability to production enhancement support the oil and gas industry through consistent supply.
- Optional Calcium Chloride Addition – Wellspring Hydro is also evaluating the production of a third product of liquid calcium chloride (35% CaCl<sub>2</sub>). This proven process reacts hydrochloric acid with limestone, which would allow the business to maximize operating rates and diversify the product portfolio. Liquid calcium chloride has a strong regional demand in the Upper Midwest US and Canada for dust control and snow removal/de-icing.

#### Sustainable Use of Produced Water Waste

The execution of this project will solidify a sustainable business model built on the use of produced water waste, as defined as the Wellspring Hydro original opportunity statement.

- Through a circular economy model, 10,000 BBL per day will be used as feedstock to the salt recovery system and the Chlor-alkali facility to make products. The current disposal zone of the Dakota formation is experiencing over pressurization in certain areas, this challenge will continue as infield development of the Williston Basin continues. Wellspring Hydro offers an environmentally useful solution to simple injections.
- With an initial scope of 10,000 BBL per day, Wellspring Hydro has a vision to use technology developments for the opportunity to expand the scope and utilize more produced water. Expansion opportunities could come in various scopes; from another full-scale facility to components of this process including lithium extraction, calcium chloride production from produced water and other emerging opportunities.

#### Financial Impact

The business is projected to have a year one of \$82.6 M revenue, split between HCL at \$30.9 M, Caustic at \$47.5 M, and produced water/other at \$4.2M. The production volumes and product price forecasts are (detailed in the Business Plan) are diversified into different markets both local and regional.

- The current unleveraged financial returns yield a 21.7% IRR and \$170.0 M NPV. Year 1 EBIDTA is projected to be \$54.0 M with steady performance within +/- 5% consistency through year 5 EBIDTA at \$53.8 M. This is based on a flat price forecast to represent a conservative approach and provide opportunity of long-term contract capability.

- The full-rate state tax on product sales is expected to be \$5.5 M per year. The facility will employ a total of fifty-three employees, forty-six employees to support the cost of product and seven employees supporting administrative and company operations.

**Facilities:**

The facility will include a pre-treatment, evaporator/crystallizer system, chlor-alkali electrolytic cells, caustic evaporator, a hydrochloric acid synthesizer, and a Saltwater Disposal (SWD) well, and all associated utility, storage and loading facilities for bulk shipments via truck and rail.

Specific process facilities include.

- Salt Crystallizer & Evaporator
- Primary Brine Treatment: Brine Precipitation and Filtration
- Secondary Brine Treatment
- Brine Electrolysis
- Anolyte Handling and Dichlorination
- Catholyte Handling
- Excess Hydrogen Generation
- Chlorine Cooling & Demisting
- Cell Hydrogen Cooling & Demisting
- Hydrochloric Acid Synthesis
- Caustic Evaporation
- Sodium Hypochlorite Bleach Production & Emergency Vent System
- Liquid Calcium Chloride Production (Optional)
- Utilities

General and functional facilities include.

- Administration Offices
- Onsite Laboratory
- Storage Facilities: Water, Salt, Caustic Soda, Hydrochloric Acid

**Resources:**

Subject matter experts will assist in engineering, design, implementation, and construction.

Subject Matter Expert Resources	
Hargrove Engineers	Palmer Lawrence
Mastec Infrastructure	SHECO
FCI Constructors	Dixie Engineering
InDemand	Bertrams
Ekato	Verantis
DrM	TennyCo
Marmon Industrial Water	Mersen
American Crane	CEJCO
Applebee Church	Voigt-Abernathy
Verantis	Flowserve

Other consultants or services to be used include electricity pricing experts and legal advisors for purchasing and sales agreements. Environmental consultants may also be required to assist during reviews with the North Dakota Department of Environmental Quality.

**Techniques to Be Used, Their Availability and Capability:**

Independent, credible third-party resources will be utilized as identified in earlier sections. The subject matter expert resources will license their technology and services as a part of the procurement process to be implemented in the Wellspring Hydro design.

The availability of specialty process equipment is a critical component of the schedule with lead times of equipment reaching 14-16 months due to market constraints on key materials. As outlined in the loan fund request, Wellspring Hydro will utilize funds to secure availability with early downpayments on key items.

**Environmental and Economic Impacts while Project is Underway:**

Wellspring Hydro is committed to avoiding accidents and unplanned occurrences that may result in injury to employees, interruption of production, or damage to equipment or property. This policy, applies to every task undertaken, is to take every action necessary in engineering, planning, assigning, and supervising all jobsite operations to establish and maintain safe and healthful working conditions on our projects and protect the public and the environment.

During the scope of this project, there must be interaction between the Wellspring Hydro, Hargrove, and the appropriate North Dakota regulatory agencies to communicate details about the plant design including specific plans to address environmental and safety concerns. Wellspring Hydro, Hargrove and Mastec will work together to interpret and communicate the permit requirements so that the regulatory

requirements are clearly and specifically understood by all the contractors. Williams County has taken an active role in establishing construction and operations phase employee counts along with traffic surveys and logistical needs.

Wellspring will employ up to 250 contractors at peak construction phase. Wellspring Hydro has communicated with local authorities and plans will begin months prior to peak phase to establish transportation logistics and housing requirements for the influx of staff required to accomplish construction in an efficient manner.

The Site Manager will work with the environmental department to develop procedures for isolation of the project site for storm water runoff, testing, pumping and disposal of storm water from excavations, and containment areas. Any temporary breach of containment structures will also be addressed to assure that no contamination will reach the storm water systems.

Fire water tank installment will be critical to establishment of the site for Wellspring Hydro. The size of the tank will be appropriate for the development of the site and will be filled prior to operational start up. If other companies are building in the area a coordinated effort will be made to build out and support a local fire staff and EMS plan with local community leaders which will cover the entirety of the site build out

#### **Ultimate Technological and Economic Impacts:**

This is a first of its kind process utilizing well known and understood chlor-alkali technology that has been available since the 1970's. While oilfield brine is becoming more commonly reused, recycled, and even crystallized to derive value driven products, to our knowledge there are no other chlor-alkali plants in the world that uses oilfield produced water as its feedstock for salt. We have patented a process to leverage this waste stream to create products which are used in the industry as well as create net new surface fresh water, water that did not exist as fresh water before. The new fresh water will be used exclusively by our plant as process water needs such as cooling, ultrapure brine, cathode dilution, and salt saturation.

The business is projected to have a year one of \$82.6 M revenue and support 53 full time employees. The current unleveraged financial returns yield a 21.7% IRR and \$170.0 M NPV. Year 1 EBIDTA is expected to be \$54.0 M with steady performance within +/- 5% consistency through year 5 EBIDTA at \$53.8 M. The full-rate state tax on product sales is expected to be ~\$5.5 M per year. There will be partnership opportunities as highlighted in the Standards of Success that could have an even larger initial Economic Impact.

#### **Why the Project is Needed:**

This plant will be designed to enable recovery of more valuable salts and elements. All products to be made by Wellspring Hydro are presently consumed by businesses and industries in North Dakota but are imported from other states. This project represents a new industry for North Dakota, creating sustainable jobs and tax revenues in the state.

The output will benefit North Dakota by proving out a new concept to recover salt from a waste stream from the oil and gas fields and using it to make valuable products which are used in the industry, i.e. hydrochloric acid, caustic soda, with the potential of calcium chloride and a small amount of sodium hypochlorite (bleach) required in the State and region. All these products are used to some extent in the oil and gas industry, excess production will be exported out of state, thus generating new income for the state. In addition to the valuable commodities that will be recovered, the current disposal zone of the Dakota formation is experiencing over pressurization in certain areas, this challenge will continue as development of the Williston Basin continues. Wellspring Hydro offers an environmentally useful solution to over pressurization.

Wellspring Hydro will systematically manage our power, water, and carbon footprint to underpin North Dakota's goals as a multi-resource energy policy state. Our products support more efficient oil production, lower carbon capture costs, and resource attainment of previous waste streams. Overall Wellspring Hydro's proven concept may be utilized again as North Dakota's petrochemical industry grows.

1. Local Production of key products
2. Sustainable Produced Water Source
3. Lithium Production

## STANDARDS OF SUCCESS

Various standards of success will be identified and employed to solve the technical hurdles herein. These standards examine both the technical and commercial aspects of the project while adding depth and outlining value.

### **Reduced Environmental Impacts**

Oil and gas operations in the Williston Basin dispose of 1.5 - 1.8 million barrels (63-75 million gallons) of produced water per day. This is 25% more than all the industrial process water use in North Dakota. Wellspring Hydro's scope focuses on a portion of this current waste stream and our vision is to create valuable commodities and rare earth metals extraction through alternate water utilization.

Wellspring Hydro will separate salt and fresh water from produced water; the remaining concentrated stream (referred to as "mother liquor") will be sent to additional processes and eventually to SWD after all useful material can be economically derived. This process of crystallization, concentration and extraction will lead to a 40% reduction in produced water disposed and creation of net new freshwater, used as project process water.

The elevated concentration of remaining elements in the "mother liquor" such as lithium and magnesium along with other salts and metals, create potential for further value-added processing. Beyond the valuable commodity chemistries and essential elements, Wellspring Hydro being a first of its kind facility with healthy returns also sees itself as a champion for further process and product development in the areas of, Environmental Stewardship, Energy Efficiency, Sustainability, Economic Diversification, and Jobs Creation.

### **Increased Energy Efficiency**

Wellspring Hydro will be a key chemical supplier to the burgeoning CCS/CCUS (Carbon Capture and Storage/Carbon Capture, Utilization and Storage) industry in North Dakota and surrounding states. The Northern Plains are known for their vast coal reserves and critical baseload power generation, however changing climates both political and environmental related are now signaling the importance of CCS/CCUS. Technological advances, tax incentives, and attractive geologic CO<sub>2</sub> target zones in North Dakota are leading to testing for storage zones and will soon place North Dakota on top as the world leader in carbon capture. To achieve the status of the world's leading carbon capture State, projects such as Project Tundra at Milton R. Young station and Coal Creek Station will require large amounts of NaOH (caustic soda) to scrub sulfur dioxide (SO<sub>2</sub>) to zero. This need is driven by the Amine CO<sub>2</sub> removal technology employed in large scale carbon capture such as those at power stations that utilize coal with sulfur content. Currently all Caustic Soda is imported into the State at a premium. Wellspring Hydro will be able to supply all the States projected needs and will have 50% of its NaOH as a net export for the state to surrounding states.

Specific to the Wellspring Hydro plant, a large part of the power demand will interruptible, a benefit in managing and balancing North Dakota's electrical grid during periods of high demand. As of the

submission of this document, no less than four potential partner companies have expressed interest in striking deals for natural gas Co-Gen power generation to use stranded in-basin natural gas that may otherwise hamper oil production. Micro-grid wind, solar, heat pumps and battery backup are part of the office facility build out scope pending tax incentive confirmation and financial justification.

While Wellspring Hydro itself will have the ability to invest in a small carbon capture facility totaling up to 23,000 tons per year (as an added scope), it will not benefit from the Q45 tax credit initially due to size. Two potential partners have reached out to WSH to better understand potential carbon capture and fit. Both companies have expressed interest in “testing current technologies” in conjunction with the chlor-alkali facility.

### **Energy Sustainability**

Lithium extraction in North Dakota by Wellspring via Brine Extraction is attractive for the Williston Basin area and North Dakota for many reasons; it does not require the surface area needed when compared to traditional solution mining which demands large evaporation ponds. The potential for carbon neutrality is feasible with further partnerships focused on natural gas combustion stream aggregation or direct air capture (DAC) technologies of which Wellspring Hydro is engaged in multiple conversations with companies offering both. The water used in Wellspring hydro’s process is water that is recycled from the influent produced water stream. The process does not need the 500,000 gallons of water traditionally required to extract a single ton of lithium, Lastly, the process requires hydrochloric acid and caustic soda which Wellspring Hydro will produce at its plant. This synergistic effect further reduces the production cost of North Dakota lithium.

Wellspring Hydro’s patented process of removing salt from oilfield produced water waste concentrates the feed brine into a “mother liquor” stream. This concentrated mother liquor creates ideal feedstock as it increases the lithium by a factor of up to 4x. This concentration allows for even more efficient extraction by Wellspring Hydro and its partner over the standard brine process. Due to this concentration upgrade, the potential for up to 3.5 tons of lithium extraction per week is achievable and will yield up to \$4M in accretive revenue and 91,000,000 gallons of water saved. Lithium production in North Dakota will provide sustainable energy and local supply chain to meet the growing lithium demand – specifically in electric vehicles.

### **Value to North Dakota**

This project can lead to significant environmental, technological, and economic impacts to the state of North Dakota. Through the successful implementation of this project, Wellspring Hydro will help demonstrate the value of produced water from Oil & Gas operations while allowing for further innovative testing onsite. The ultimate standard of success would be to provide North Dakota with a key piece in a future petrochemical strategy.

## **Explanation of How the Public and Private Sector will make use of the Projects Results, and when, and in What Way**

By the end of 2025, carbon capture projects, oil and gas and other local industries will enjoy up to a 30% cost reduction and consistent supply of essential commodities. This is driven by a subsidized feedstock of produced water from oil and gas production and/or salt cavern development. Caustic soda (carbon capture, crude refining, bio refining, gasification water process treatment, power generation water treatment, lithium extraction), Hydrochloric Acid (oil and gas operations, lithium extraction), and North Dakota Counties (Calcium Chloride – dust control, oil and gas) will all benefit from Wellspring Hydro's strategic location, differentiated feedstock, and low operating cost in Western North Dakota. These products which are all purchased outside of North Dakota currently will immediately realize a large logistical cost savings over current suppliers who rely on rail and trucking to bring current products in from thousands of miles away. Caustic soda is essential in water treatment performed as a part of routine preventative maintenance at many industrial plants in North Dakota, however the largest use of caustic will be sulfur dioxide scrubbing at the planned carbon capture projects at Milton R. Young Station and Coal Creek Station power plants. These projects will together consume nearly half of Wellspring Hydro's caustic soda production. Current supply chains are not set up for this increase in use by North Dakota which would only lead to higher than projected operating costs or potential delays and shutdowns due to lack of consistent supply without Wellspring Hydro to fill the increased caustic need by these essential projects.

Currently oil and gas completions and operations are finding it difficult to locate consistent hydrochloric acid streams and most transloading companies are looking to bring in product from as far away as Texas where they must compete with the Permian Basin demand. This adds delays and significant cost increases due to long logistics routes and creates supply-demand constraints on the limited existing streams. Wellspring Hydro's plant would eliminate the need for North Dakota oil and gas producers to go outside the State for hydrochloric acid and furthermore would allow for North Dakota to become an exporter of HCl to the surrounding region.

Wellspring Hydro will evaluate an expansion into Calcium Chloride production, which has significant value to both the private and public sector. Like oil and gas operators, the counties in North Dakota purchase many commodity products that must be trucked or railed in from out of state. Magnesium Chloride ( $MgCl_2$ ) and Calcium Chloride ( $CaCl_2$ ) both come exclusively from out of state production. North Dakota and surrounding states (SD, MT, MN) utilize a high volume of these products for dust control. The annual consumption of calcium chloride for North Dakota is 5.6 thousand metric tons, and 18.1 thousand metric tons for the surrounding states. In addition, the US and Canada are large consumers of deicing products due to harsh winter conditions.  $CaCl_2$  outperforms  $MgCl_2$  and has a lower environmental impact. Wellspring Hydro has the operational flexibility to produce a large portion of the  $CaCl_2$  used by North Dakota and export to the surrounding states.



**How the project will enhance the research, development and technologies that reduce environmental impacts and increase sustainability of energy production and delivery of North Dakota’s energy resources.**

Wellspring Hydro will enhance the development and operations of technologies that reduce environmental impact by supplying crucial raw materials to processes used in carbon capture. Materials that will have the lowest environmental footprint of any commodities on the market. This is due to extremely short supply chains, a zero-emission production facility, and use of a current waste stream for a feedstock.

With its own facility, Wellspring Hydro will work to create a proposed test facility to implement and trial new and emerging technologies and processes. The focus of which would be threefold in a nonspecific order, first to reduce environmental impact, second to lower cost associated with WSH and adjacent projects, third to remain on the forefront of developments in the energy and commodity sectors.

To date Wellspring Hydro has discussed partnerships with companies covering.

### Partnership Requests (30 total)

- Lithium Extraction (6)
- Carbon Capture (4)
- Salt cavern development and support (3)
- Natural gas Co-Gen (4)
- Magnesium chloride production (2)
- Potash solution mining (1)
- Calcium chloride production (2)
- Customized commodity chemical blending (2)
- Water recycle and reuse for industrial process water supply(3)
- Water recycle for Ag reuse (1)
- Alternate SWD zone development (2)

It is important to remember the listed partnership opportunities will be completely stand-alone partnerships, JVs, or licensing opportunities. These will only represent the upside on the current business plan and financial outlook through combined synergies. The opportunities listed show the strategic nature of looking at our assets in North Dakota from a different vantage point which allows for the investigation of innovative ideas in a field environment following laboratory confirmation.

**How it will preserve existing jobs and create new ones.**

Wellspring Hydro will preserve existing jobs by supporting the oil and gas industry through lower costs, readily available commodities to ensure wells can be completed and produced at a \$/barrel that is in line with that of competing states. The Wellspring Hydro production plant will create fifty-three full-time high-paying jobs ranging from front office to production crews.

As detailed in the previous section, Wellspring Hydro's unique intersection of industrial process, commodities production, and oil and gas water reuse it will present an opportunity for further testing and expansion for innovation in an environmentally sustainable format due to the inherent natural assets in Northwestern North Dakota.

## BACKGROUND/QUALIFICATIONS

### Leadership Team

Wellspring Hydro management team is supported by industry and local resources to develop a robust business plan and positioned to execute with investment.



**Steve and Carla Kemp**, Founders, Wellspring Hydro.

- Steve and Carla are local entrepreneurs that founded Wellspring Hydro in 2016 and are based in Williston, ND. Steve and Carla have started multiple ventures in IT, real estate, and financial markets.



**Mark Watson**, CEO, Wellspring Hydro.

- Mark has over 13 years-experience in acquisitions/mergers, project management, and entrepreneurial start-ups. Mark, MBA, specializes in developing business plans, financial modeling, marketing analysis, and valuation/capital funding.



**Mat Hirst**, COO, Wellspring Hydro.

- Mat has over 16 years-experience in developing sales and operations teams in the oil and gas industry. Mat, based in Bismarck, ND, specializes in water technologies with expertise in executing sales strategies, people management, and driving operational efficiencies.



**Norm Christensen**, Technical Advisor, Wellspring Hydro.

- Norm's career has spanned more than 40 years, including direct involvement in the chlor-alkali industry in both North and South America. A chemical engineer, Norm has held senior positions in both Fortune 100 and small companies in engineering, operations, sales and marketing and general management roles. Norm recently (2015) oversaw on the construction of a chlor-alkali facility in San Antonio, TX.

## Partners & Suppliers

Wellspring Hydro has worked with subject matter experts to validate components of the business plan from our engineering leads and local partners.

A few key leads from the project team consists of the following individuals:

- **Scott Cooper**, Project Lead, Hargrove Engineers + Constructors. Scott has thirty years of experience working in project management and design engineering. Has established project procedures, coordinates changes in scope, monitors and controls engineering activities, cost analysis, planning, scheduling, estimating, procurement of process equipment. Scott is the project lead for the Wellspring Hydro FEL-2 and upcoming FEL-3 projects.
- **Justin C Merritt**, P.E, Hargrove Engineers + Constructors. Justin has over eighteen years of experience in a variety of process industries, including chlor-alkali, petrochemicals, minerals processing, biofuels, and lithium. Project experience includes work on six chlor-alkali plants.
- **Amanda Hayes**, Process Engineer, Hargrove Engineers + Constructors. Amanda has over fifteen years of experience as a Process Engineer in the chemical industry. Experience in writing procedures, process safety management, root cause analysis, and process studies.
- **Bill Johnson**, Project Manager, Hargrove Engineers + Constructors. Bill has over twenty-five years of experience as a Process Engineer in the chemical industry. Experience in writing procedures, process safety management, root cause analysis, and process studies.
- **Chuck Carr**, VP Strategic Insights, Chemical Market Analytics (Formerly IHS Markit). Chuck serves as the group lead for consulting projects, primarily responsible for the sale and execution of consultant engagements in the Americas region.
- **Justin Anderson**, Director of Operations, Savage Services. Justin manages operations and business development for Savage Services in the North Dakota region. Justin has helped negotiate an LOI for a logistics and transload partnership, that includes capital investment.



## **MANAGEMENT**

Wellspring Hydro will operate a steering team consisting of the Wellspring Hydro management team, Hargrove project and engineer leads and Tormod operations group. The steering committee will meet monthly to review the strategic process of execution including project timeline, cost projections, regulatory approvals and other critical item highlighted by the working team.

### **Monthly Steering Team Meetings**

Executive Review with the steering team to evaluate progress and assess critical actions, risk register and schedule.

The project will be organized as an integrated team, containing representatives from both Wellspring Hydro, Mastec and Hargrove. The Activities of the project will be coordinated by a core Project Team, the main members of which will be: (full role descriptions available for reference in business plan)

### **Weekly Project Meetings**

During the kick-off meeting for Initial Detail Design, an agreement for the time, place and format of the weekly project meeting will be agreed upon. The purpose of this meeting is to maintain an open line of communication between all parties. These meetings will be transitioned to the field during the construction phase. The agenda will be as follows:

- Upcoming Safety Reviews
- Design Safety Concerns
- Calendar of Events
- Planned Field Trips
- Last Week Accomplishments
- Key Milestones for the Coming Week
- Outstanding Action Items
- Schedule
- Current week releases
- Events

### **Weekly Reports and Meetings**

The Project Manager will issue weekly progress reports which will describe the progress of Hargrove services and of other project participants and will evaluate the progress and performance of the project team against the project plan. The weekly meeting format will be changed to focus on issues that need attention and should publish meaningful and useful metrics that update everyone on progress versus plan.

Wellspring Hydro Steering Team			
Mark Watson			
Scott Cooper			
TBD - Investor Appointed Lead			
TBD - Third Party Industry Expert			
Engineering Stage		Construction Stage	
Role	Lead	Role	Lead
Operations Lead – Mat Hirst			
Wellspring Project Manager	TBD	Construction Manager	Mastec
Hargrove Process Principal	Scott Cooper	Site Manager	Mastec
Hargrove Project Engineer	Bill Johnson	Quality Manager	Mastec
Wellspring Process Lead	Norm Christensen	Field Materials Supervisor	Mastec
Wellspring Start-Up Manager	TBD	Controls Manager	Mastec

### Wellspring Hydro Operations Lead – Mat Hirst

Finalize the plant data by the development of the Engineering contractor’s data to include commissioning and other records required for the future operation of the plant. Identify system start-up requirements.

### Wellspring Hydro Project Manager – TBD

Accountable to the Steering Committee; acquire, direct, and control all the resources required to implement the project from development through to beneficial manufacture so that the business intent, as expressed in the Project Proposal or subsequent amendments, can be achieved.

### Hargrove Project Principal – Scott Cooper

Accountable to the Wellspring Hydro Project Manager, the role holder will be responsible for the provision of Hargrove resources to deliver the project scope of work.

### **Hargrove Project Engineering Manager – Bill Johnson**

Accountable to the Hargrove Project Principal, and responding to the Wellspring Hydro Project Manager, the role holder will be responsible for the coordination of design activities to meet the project time, cost, and quality targets.

### **Wellspring Hydro Process – Norm Christensen**

Responsible for the production review of process packages including PFDs, P&IDs, equipment data sheets and process description.

### **Wellspring Hydro Start-up Manager – TBD**

Define and implement a start - up plan, detailing Plant Systems, procedures, resources, and responsibilities for all stages of plant turnaround and commissioning by setting and monitoring measures of performance in order to achieve the agreed schedule.

### **Construction Manager – Mastec**

Mastec will utilize its construction management organization to fulfill its construction obligations. Mastec will manage all construction activities required to complete the work to the point of being ready for commissioning.

### **Site Manager - Mastec**

The site manager will report to the project manager on the project and will coordinate all functions with the Wellspring Hydro Operations Manager for all construction-related matters. The site manager will be responsible for:

### **Quality Manager - Mastec**

The Project Quality Manager will perform or cause to be performed those inspections required by the project specifications. He will also review and approve the Quality Plans of all the subcontractors and audit the quality control records of the contractors (e.g., welder certifications).

### **Field Materials Supervisor - Mastec**

The field materials supervisor will be responsible for all field procurement-related activities including receiving, inspecting, and warehousing all engineered items at the site. Field purchasing of bulks will be performed by the individual trade contractors.

### **Controls Manager - Mastec**

During construction, the project controls manager will be responsible for coordinating cost, planning, and scheduling activities of all subcontractors to provide the management tools for controlling construction cost and schedule. Reporting will be provided to Wellspring Hydro which will be appropriate to the form of contracts and as determined the project controls plan.

## TIMETABLE

The timeline is based cumulative outlook for the FEL-3 study, market research study and the combined output analysis.

### Critical Milestones:

Milestone	Milestone Date
FEL-3/DD Kick Off Meeting	15 Feb 23
FEL-3 Complete	15 Jun 23
Financial Investment Decision (FID)	01 Sep 23
Field Validation – Technology and Commercial	01 Nov 23
Initial Detailed Design	01 Dec 23
Procurement of Specialized Equipment	01 Jan 24
Detail Design Complete	23 Jun 24
Construction Mobilization	04 Jan 24
All Major Equipment	03 Oct 24
Mechanical Completion	05 Sep 25
Start-Up	31 Oct 25

### Full Project Timeline:

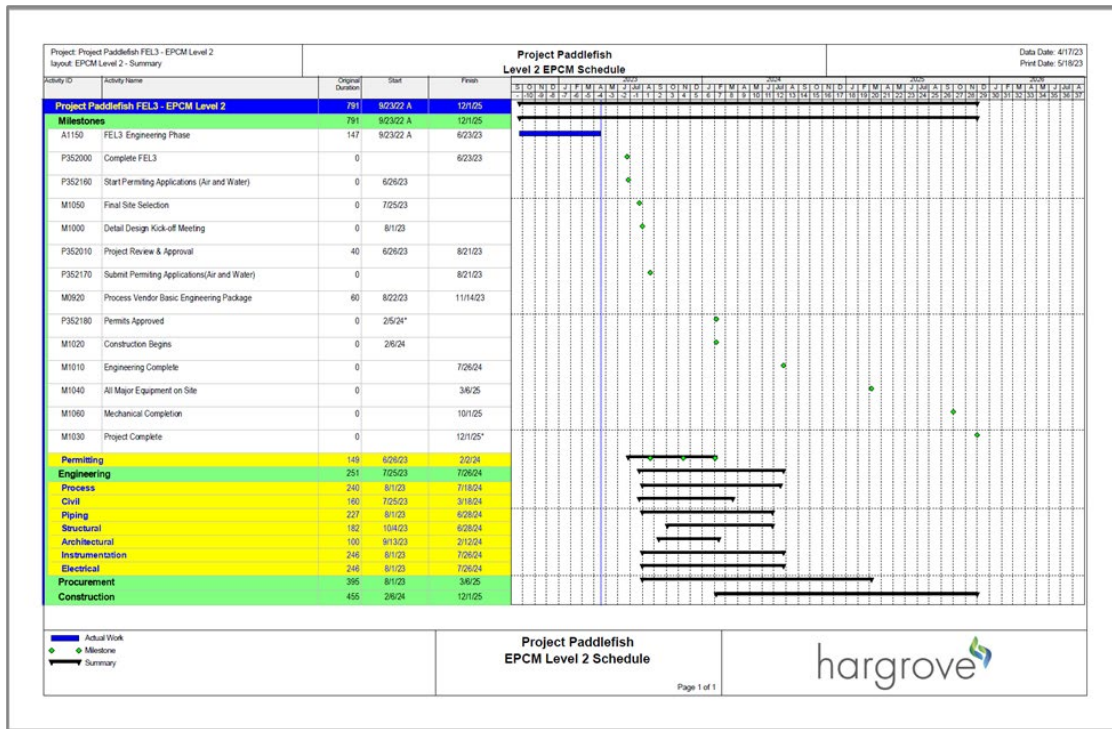



## BUDGET

As referenced in the management section, Wellspring Hydro will have monthly updates on cost/budget reports in addition to the criteria set by the CSEA process.

Project Associated Expense	NDIC's Share	Applicant's Share (Cash)	Applicant's Share (In-Kind)	Applicant's Equity Investment	Total
Technical and Commercial Viability	\$2,000,000*			\$2,000,000	\$4,000,000
Initial Detailed Design	\$3,000,000*	-	-	\$3,000,000	\$6,000,000
Process Equipment	\$50,000,000**			\$50,000,000	\$100,000,000
Detailed Design				\$8,500,000	\$8,500,000
Chlor-Alkali Facility				\$131,386,700	\$230,386,700
<b>Total</b>	<b>\$55,000,000</b>	<b>-</b>	<b>-</b>	<b>\$5,000,000</b>	<b>\$250,886,700</b>

\*Designates grant fund budget - \$5,000,000 USD

- Technical and Commercial Viability - \$5,000,000 USD
  - Consultants and Technical Support - \$506,550 USD
  - Stage 1 Field Trial - \$650,000 USD
  - Stage 2 Field Trial - \$3,843,350 USD
- Initial Detailed Design - \$5,000,000 USD
  - Quoted by Hargrove as first 6 months of detailed design for required engineering and technical support to make procurement decisions.

\*\* Designates loan fund budget - \$50,000,000 USD

- Specialized Process Equipment - \$50,000,000 USD

## CONFIDENTIAL INFORMATION

A person or entity may file a request with the Commission to have material(s) designated as confidential. By law, the request is confidential. The request for confidentiality should be strictly limited to information that meets the criteria to be identified as trade secrets or commercial, financial, or proprietary information. The Commission shall examine the request and determine whether the information meets the criteria. Until such time as the Commission meets and reviews the request for confidentiality, the portions of the application for which confidentiality is being requested shall be held, on a provisional basis, as confidential.

If the confidentiality request is denied, the Commission shall notify the requester and the requester may ask for the return of the information and the request within 10 days of the notice. If no return is sought, the information and request are public record.

Note: Information wished to be considered as confidential should be placed in separate appendices along with the confidentiality request. The appendices must be clearly labeled as confidential. If you plan to request confidentiality for **reports** if the proposal is successful, a request must still be provided.

To request confidentiality, please use the template available at <http://www.nd.gov/ndic/CSEA-app-doc-infopage.htm>.

Wellspring Hydro has submitted for the attached Business Plan as confidential information by CSEA and the state of North Dakota. This document holds confidential and proprietary information around the research, development, and execution of the novel Wellspring Hydro project.

## **PATENTS/RIGHTS TO TECHNICAL DATA**

*Any patents or rights that the applicant wishes to reserve must be identified in the application. If this does not apply to your proposal, please note that below.*

This is a first of its kind process utilizing well known and understood technology that has been around since the 1970's. As included in the CSEA Grant scope from December 2021, Wellspring Hydro will complete the process patent application with the results of the FEL-3 defined engineering and design study. This process patent will illustrate a process to leverage this waste stream to create products which are used in the industry as well as create net new fresh surface water. This process is expected to begin in June 2023.

## STATE PROGRAMS AND INCENTIVES

*Any programs or incentives from the State that the applicant has participated in within the last five years should be listed below, along with the timeframe and value.*

Wellspring Hydro has a long-standing partnership with North Dakota from the original concept stage supported by UND, NDIC and City of Williston. The support from the state has allowed Wellspring Hydro to fund the research and development into this novel process (patent pending).

Agreement	Company/Division	Investment	Commentary
Research Grant	NDIC	\$110,000	Concept support with UND partnership starting in 2016
Grant Match	City of Williston Star Fund	\$225,000	Investment into Concept Stage and FEL-2 Engineering with development in Trenton
Promissory Note	ND Dev Fund	\$250,000	Investment into successful FEL-2 engineering and design work in 2020
Promissory Note	ND Dev Fund	\$750,000	Investment into commercial and technical development, highlighted by Veolia Pilot Lab
Grant	NDIC – CSEA Fund	\$1,000,000	CSEA Grant awarded in December 2021 for FEL-3 engineering & design
<b>Total Investment</b>		<b>\$2,335,000 USD</b>	

\*Promissory notes and grant detail can be provided upon request.

# APPENDIX



# Tax Liability Statement



STATE OF NORTH DAKOTA  
**OFFICE OF STATE TAX COMMISSIONER**  
BRIAN KROSHUS, COMMISSIONER

May 15, 2023

Ref: L1420911744

TRIPLE 8 LLC  
WELLSPRING HYDRO  
PO BOX 884  
WILLISTON ND 58802-0884

I, Brittany Herberholz, Supervisor of Tax Registration for the North Dakota Office of State Tax Commissioner, certify that the records in the North Dakota Office of State Tax Commissioner do not show any indebtedness owed to the State of North Dakota by TRIPLE 8 LLC, with respect to income taxes, sales and use taxes, or any other taxes collected by and payable to the Tax Commissioner's office. This company is, therefore, in good standing with the North Dakota Office of State Tax Commissioner. This certification does not include ad valorem property taxes collected by the respective county treasurers.

Dated this May 15, 2023 at Bismarck, North Dakota.

Brittany Herberholz  
Supervisor, Tax Registration

TAX.ND.GOV | TAXINFO@ND.GOV  
600 E. BOULEVARD AVE., DEPT. 127 | BISMARCK, ND 58505-0599  
PHONE: 701-328-7088 | TTY: 800-366-6888



## Primary Sector Certification



July 15, 2020

Steve Kemp  
Wellspring Hydro  
PO Box 884  
Williston, ND 58802

Dear Steve:

Thank you for your application for primary-sector certification by the North Dakota Department of Commerce, Economic Development & Finance Division. We have reviewed your application and determined that ED&F can certify your company, **Wellspring Hydro**, as primary sector and a new wealth creator in the economy of North Dakota. This certification is valid for **four years** from today's date (expires 7/14/2024).

Most of North Dakota's economic development programs, tools and incentives are targeted toward primary-sector clients. You may be requested to provide a copy of this primary-sector certification letter when you apply for certain economic development incentive and funding programs.

This certification does not guarantee the receipt of any North Dakota business incentive. For example, there are additional qualification criteria for the Seed Capital Investment and Agricultural Business Investment personal income tax credits, and it is critical that investments **NOT** be made prior to the business receiving certification for these two credits. If you are pursuing certification for investment tax credits and need to know the criteria required for qualification, contact Joe Cicha 701-328-7283.

This certification is not the application process for the North Dakota New Jobs Training Program administered by Job Service North Dakota. To apply for the North Dakota New Jobs Training Program, you must contact Job Service North Dakota for the required application forms. Application forms for other programs that require primary sector certification are available from the agency administering the program.

Also, companies and individuals pursuing the investment tax credit incentive are reminded there is a cap on available dollars. Please visit with the ND Office of the Tax Commissioner regarding the remaining balance for investment tax credits. The credits are available on a first-come-first-serve basis until the law-defined cap is met.

North Dakota appreciates your contribution to the citizens and economy of our state. If there is anything further we can do to assist your company, please contact us at 701-328-5300.

Sincerely,

A handwritten signature in black ink, appearing to read "James Leiman", written over a horizontal line.

James Leiman, Director  
Economic Development & Finance Division

1600 E Century Avenue, Suite 2 | P.O. Box 2057 | Bismarck, ND 58502-2057

PHONE: 701-328-5300 | TOLL-FREE: 1-866-4DAKOTA | ND RELAY TTY: 1-800-366-6888 | VOICE: 1-800-366-6889 | NDCommerce.com

## Letter of Support – City of Williston 1



May 17, 2023

Clean Sustainable Energy Authority  
600 East Boulevard Ave  
Bismarck, ND 58505

Subject: Letter of Recommendation for Wellspring Hydro's Chlor Alkali and Lithium Mining Project

Dear Members of the Clean Sustainable Energy Authority,

I am writing on behalf of the City of Williston to express our robust support for the May 2023 Application for Clean Sustainable Energy Authority submitted by Wellspring Hydro for their Chlor Alkali and Lithium mining project.

As a city that thrives on the energy sector, we understand the crucial importance of innovation, sustainability, and diversification for the longevity and prosperity of our regional economy. We firmly believe that Wellspring Hydro's project will be a cornerstone in this context, providing a sustainable and cost-effective solution that is crucial for the continuation of traditional oil and gas operations.

Wellspring Hydro's pioneering approach to Chlor Alkali and Lithium mining promises not only to secure a dependable supply of hydrochloric acid, which is fundamental for well completion, but also to ensure a consistent provision of caustic soda, which has wide-ranging industrial applications. By driving down the costs of these key resources, the project could significantly enhance operational efficiency and cost-effectiveness within our industry.

Furthermore, the emphasis on Lithium mining echoes the global shift towards clean energy. As Lithium is a key component in the production of batteries for electric vehicles and renewable energy storage systems, the project's potential to strengthen the domestic Lithium supply chain aligns with our aim to diversify and fortify our regional economy, while reducing dependence on foreign resources.

[www.cityofwilliston.com](http://www.cityofwilliston.com)

T. 701-713-3800  
F. 701-577-8880

22 East Broadway  
Mailing Address: PO Box 1306 Williston, ND 58802



## Letter of Support – City of Williston 2

May 17, 2023

Page Two

The City of Williston is therefore proud to endorse Wellspring Hydro's Chlor Alkali and Lithium mining project. We are convinced that their innovative approach, coupled with their commitment to sustainability and economic diversification, will make a lasting and positive impact on our region and the broader energy industry. We strongly recommend that the Clean Sustainable Energy Authority approve their May 2023 application and extend the necessary support for this transformative project.

Thank you for considering our recommendation. Please do not hesitate to contact us if you need any further information or clarification.

Sincerely,



Shawn Wenko  
Interim City Administrator

[www.cityofwilliston.com](http://www.cityofwilliston.com)

T. 701-713-3800  
F. 701-577-8880

22 East Broadway  
Mailing Address: PO Box 1306 Williston, ND 58802

## Letter of Support – UND

DocuSign Envelope ID: E6A3E28F-EAD8-43FA-8DB4-01869E5384A3



COLLEGE OF ENGINEERING & MINES

UND.edu

Office of the Dean  
Upson II, Room 165  
243 Centennial Dr Stop 8155  
Grand Forks, ND 58202-8155  
Phone: 701.777.3411  
Fax: 701.777.4838  
Website: engineering.UND.edu

May 19<sup>th</sup>, 2023

To Whom it May Concern

Re: Letter of Support for Wellspring Hydro to the Clean Sustainable Energy Authority

This letter provides support for Wellspring Hydro's continued effort to build a chlor-alkali plant in North Dakota that will convert produced water from the Bakken into commodity chemicals with high market potential in North Dakota and the surrounding region. The proposed plant provides an excellent alternative to disposing of the produced waters while simultaneously producing feedstock chemicals that can be used to support the continued development of the oil industry in the state. The electric power industry and the transportation sector also represent significant market opportunities. We have explored several treatment options for produced water, including the chlor-alkali option. As a subcontractor in the preliminary work done in conjunction with Barr Engineering, we performed a variety of bench-scale tests and modeling efforts to help determine both the technical and economic viability of the approach proposed by Wellspring. Through this team effort, a process scheme was developed that used proven technology to produce caustic soda and hydrochloric acid as the primary products, taking advantage of the high sodium chloride level in the Bakken brines. The results of the feasibility study performed under the Barr Engineering contract have demonstrated the technology represents a good investment opportunity.

We applaud Wellspring Hydro for their pending completion of the FEL-3 study that now provides the detailed information needed by Wellspring to raise the capital required to build the plant. The plant will provide a lower-cost option for dealing with the produced water than the current disposal methods, with the added advantage of improved public perception availed by reducing the amount of deep-well injection required. The HCl can be used locally, and likely be made available to the industry at a price lower than that currently paid as Wellspring will avoid the premiums attached to the current supply due to trainload, rail, and distribution fees from the current suppliers. The recovered salts also provide opportunities for additional product development, such as caustic soda to be used in carbon capture at our critical coal fired power plants, calcium chloride for dust control, and lithium recovery to be used in battery production.

I am happy to provide my endorsement to their business plan as it represents a good opportunity for the State of North Dakota and a good investment opportunity.

Sincerely,

DocuSigned by:

00FF8379C080464

Daniel Laudal, Ph.D.  
Executive Director  
College of Engineering & Mines Research Institute  
University of North Dakota  
[daniel.laudal@und.edu](mailto:daniel.laudal@und.edu)

The University of North Dakota is an equal opportunity / affirmative action institute.

## Letter of Support – Commerce



May 19, 2023

Subject: Letter of Support for Wellspring Hydro's Chlor Alkali and Lithium Mining Project

Dear Members of the Clean Sustainable Energy Authority,

I am writing to express the North Dakota Department of Commerce's support for Wellspring Hydro's Chlor Alkali and Lithium mining project in their Application to the Clean Sustainable Energy Authority. Wellspring Hydro has demonstrated an impressive commitment to innovation within a mature industry, paving the way for economic growth and environmental sustainability. By manufacturing traditionally imported products locally, Wellspring Hydro will contribute to the generation of net new revenue for the State of North Dakota. Specifically, the production of Hydrochloric Acid (a key commodity in the oil industry) and Caustic Soda (a critical commodity in carbon capture) will help keep two key parts of the energy industry in North Dakota competitive.

Wellspring Hydro's project encompasses the mining of Lithium from produced water. As the demand for Lithium continues to soar within the renewable energy sector, this aspect of the project uniquely bridges the traditional oil and gas industry with the emerging renewable energy sphere. It presents an extraordinary opportunity for North Dakota to establish its relevance and prominence in the renewable energy landscape.

The North Dakota Department of Commerce fully recognizes the significance and potential impact of Wellspring Hydro's Chlor Alkali and Lithium mining project. We believe that this venture is well aligned with our state's vision for economic diversification, job creation, and sustainable practices. The project addresses supply constraints, contributes to the local economy, and fosters collaboration between different sectors.

Sincerely,

A handwritten signature in black ink that reads "Richard Garman".

Richard Garman, Director  
Economic Development & Finance Division  
North Dakota Department of Commerce

1600 E Century Avenue, Suite 6 | P.O. Box 2057 | Bismarck, ND 58502  
PHONE: 701-328-5300 | TOLL FREE: 1-866-4DAKOTA | ND RELAY TTY: 1-800-366-6888 | VOICE: 1-800-366-6889 |  
NDCommerce.com

## Letter of Support – Pivotal

DocuSign Envelope ID: 8F332CCF-D8EB-4B30-9056-3EB761097BE5



Pivotal Energy Partners Inc.  
Suite 510, 736 – 6<sup>th</sup> Avenue SW  
Calgary, AB T2P 3T7  
Pivotalenergy.ca

May 16, 2023,

Dear Members of the Clean Sustainable Energy Authority,

I am writing to express Pivotal Energy Partners enthusiastic support for the May 2023 Application for Clean Sustainable Energy Authority submitted by Wellspring Hydro for their Chlor Alkali and Lithium mining project in Northwest North Dakota. As an innovative energy company, we recognize the significance of this project and its potential to transform and support both traditional oil and gas operations as well as the clean energy sector.

One of the most compelling aspects of Wellspring Hydro's project is their innovative approach to resource utilization. Pivotal is a trusted midstream company that strategically bridges the logistical and financial gap between our partners and the target marketplace for their products. Through a cooperative, transparent approach, we work with our partners to increase netbacks, lower operating costs, and maximize margins. We strive to provide partnerships that are fueled by an unparalleled level of trust and transparency in all that we do. We have intentionally designed our services to provide a model that is flexible and adds value in a safe and economical manner. Our fully scalable, modular facilities are built to meet capacity demand for our partners. We have aligned with industry-leading technology developers to further optimize our services for our partners.

Pivotal is also dedicated to the highest environmental protection and safety standards throughout all levels of our organization. This level of commitment ensures a workplace that protects the health and safety of our employees, contractors, and the communities in which we operate.

We see Wellspring Hydro as a potential partner for future projects of our own and strongly feel that they fit in with many of our core initiatives. Local manufacturing will create opportunities to increase plant netbacks while lowering local logistics, operating cost in North Dakota remain attractive due to lower energy costs and inexpensive land. The environmental components of Wellspring are game changers as they allow for the beneficial use of a current waste stream and the potential to generate lithium for the renewable energy sector. Water consumption will be significantly lower than current mining operations and near zero when the plant is running optimally.

Pivotal is proud to endorse Wellspring Hydro's Chlor Alkali and Lithium mining project. We believe that their innovative approach and dedication to sustainability, coupled with our collaboration, will make a lasting and positive impact on the energy industry. We strongly encourage the Clean Sustainable Energy Authority to approve their May 2023 application and provide the necessary support for this transformative project.

Thank you for considering our recommendation. Please do not hesitate to contact us if you require any additional information or clarification.

Sincerely,

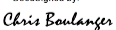
DocuSigned by:  
  
Chris Boulanger, President – Pivotal Energy Partners USA

## Letter of Support – OneCor



May 16, 2023,

Dear Members of the Clean Sustainable Energy Authority,

OneCor Services would like to show our support for the Wellspring Hydro project to build a chlor alkali facility in Northwest North Dakota. The need for local industrial commodity chemicals manufactured in a sustainable manner that cuts down significantly on logistical cost will help continue the extensive development of the Williston Basin.

At OneCor Service we are a Williston, ND based company with offices in Watford City, ND, Odessa, TX, and San Antonio, TX. We pride ourselves as community members who are a premium provider of several crucial services that support the oil and gas industry. Including Hydrochloric acid supply, logistics, and custom blending, Geoprobe Drilling, Environmental services, Weed Control and Pressure pumping.

A challenging and oftentimes limiting factor that all services companies experience in the Williston Basin are limited availability of products and significantly higher logistical costs when compared with other basins that we operate in. This has a trickle-down effect that touches every component of the drilling, completions and production life cycle in the oil and gas production. Hydrochloric acid typically must go through several other companies to arrive in basin at which point the end uses sees a premium to their P&L. Innovations which Wellspring Hydro are working towards will allow ND operators to achieve reduced operating costs due to lower priced in basin logistics.

There are also many ways OneCor sees Wellspring Hydro impacting our local economy by bringing in up to 55 high paying jobs, 80M in annual revenue as an exporter of low carbon chemicals manufacturing. This all leads to greater recognition on a global scale for the innovation we see every day in North Dakota.

In summary, we at OneCor strongly support Wellspring Hydro and their goal of utilizing Williston Basin waste salt water to supply an innovative chlor alkali facility and extract lithium.

Thank you for considering our recommendation. Please do not hesitate to contact us if you require any additional information or clarification.

Sincerely,

Tom Bachmeier

A handwritten signature in black ink, appearing to read "Tom Bachmeier".

Chief Executive Officer

## Letter of Support – Cerilon



NDV-2010-LTR-0001  
2023-MAY-18

**Clean Sustainable Energy Authority**  
14033 - 49 Street NW  
Williston, ND, 58801

Dear Members of the Clean Sustainable Energy Authority,

I am writing to express Cerilon Inc.'s support for Wellspring Hydro's innovative Chlor Alkali and Lithium Mining Project. As a company deeply embedded in the energy sector, we understand the pressing need for sustainable practices, and believe in the potential of their project.

At Cerilon, we support the numerous benefits that Wellspring Hydro's project offers, specifically the production of caustic soda, an important chemical in our operations. By securing a stable and cost-effective supply of this chemical, the Cerilon GTL project will enhance production efficiency and drive down operational costs. The Wellspring Hydro's Project aligns with our commitment to sustainably obtain essential production materials in an environmentally conscious manner.

By endorsing this project, we align ourselves with Wellspring Hydro's vision for a diversified, robust, and sustainable regional economy. We urge the Clean Sustainable Energy Authority to recognize the potential of this project and provide it with the necessary support and approval.

Sincerely,

A handwritten signature in dark ink, appearing to read "Nico Duursema", is positioned above the printed name.

**Nico Duursema**  
Chief Executive Officer

**CERILON INC.**  
First Canadian Centre  
350 - 7 Avenue SW, Suite 2900  
Calgary, Alberta, Canada T2P 3N9

+1.403.264.8044  
info@cerilon.com  
Cerilon.com

Submitted by: HydroStrat GP  
 Project Duration: 3 years  
 Total Project Costs: \$2,300,000,000  
 Request for: \$10,000,000 grant

**Summary of Project:** This project supports the extraction of minerals from produced water and the reclaiming fresh water from produced water for industrial and agricultural uses.

**Technical Review Results**

Overall Technically Sound (183/315)		
Good		
Fair		
Questionable	1	

**BND Economic Feasibility Recommendation**

Overall Economic Feasibility	
Yes	X
No	

**Technical Committee Scores**

	Score (Out of 50)
Charlie Gorecki	Abstain
Josh Teigen	31
Dave Glatt	32
Lynn Helms	35 with conditions
Justin Kringstad	34
Rachel Retterath	32
Todd Steinwand	29
John Weeda	30

Average: 32

**Recommendation: 8-0 Consider funding with condition that only Tasks 1.2, 1.5, and 1.6 are funded for a total of \$2.325 million**

# TECHNICAL REVIEWERS' RATING SUMMARY

## C-04-H

Enhancement of Energy Infrastructure

Submitted By: HydroStrat GP

Date of Application: May 2023

**Request for \$10,000,000 Grant**

**Total Project Costs \$2,300,000,000**

Technical Reviewer

**H3**

Rating Category	Weighting Factor	Rating	Weighted Score
1. Objectives	3	3	9
2. Impact	9	3	27
3. Methodology	9	2	18
4. Facilities	3	2	6
5. Budget	9	3	27
6. Partnerships	9	3	27
7. Awareness	3	3	9
8. Contribution	6	4	24
9. Project Management	6	3	18
10. Background	6	3	18
	315	183	183

**OVERALL TECHNICALLY SOUND**

GOOD (IF > 214)

FAIR (200-213)

QUESTIONABLE (IF < 200)

Diversification Delivery:	Yes	No
Project enhances the production of clean sustainable energy, to make the State a world leader in the production of clean sustainable energy, and/or to diversify and grow the State's economy.		✓
Commercialization or Development/Expansion:	Yes	No
Concept will lead to the <b>large-scale development and commercialization</b> of projects, processes, activities, and technologies that reduce environmental impacts and/or increase sustainability of energy production and delivery.	✓	



In State Requirement:	Yes	No
The funds distributed from the financial assistance are to be applied to support in-state activities and must have other sources of financial support.	✓	

- The objectives or goals of the proposed project with respect to clarity and consistency with Clean Sustainable Clean Energy Authority goals of projects, processes, activities, and technologies that reduce environmental impacts and increase sustainability of energy production and delivery are: 1 – very unclear; 2 – unclear; 3 – clear; 4 – very clear; or 5 – exceptionally clear.**

**Reviewer H3 (Rating 3)**

The objectives stated focus on fertilizer production with only a vague reference to lithium extraction. While fertilizer production is useful to North Dakota, it is not clean energy. Using 20,000 bbls/day of produced water does not make a significant dent in our daily production.

- The objectives will make a difference in the near term to the state’s economy: 1 – no impact; 2 – small impact; 3 – likely impact; 4 – most likely impact; or 5 – significant impact.**

**Reviewer H3 (Rating 3)**

Once again the focus is on fertilizer production. While impactful to agriculture, it is not significant to energy production. The only impact will be a slight reduction in produced water disposal. There is a potential for greater economic impact but it was not discussed.

- The quality and clarity of the methodology in the proposal is: 1 – well below average; 2 – below average; 3 – average; 4 – above average; or 5 – well above average.**

**Reviewer H3 (Rating 2)**

While there was discussion on drilling wells and EERC involvement, the overall methodology is not clear. How is testing to be accomplished? How and where will water be obtained? How does the process work? Much is still not worked out with no fallback if a goal cannot be reached.

- The facilities and equipment available and to be purchased for the proposed pilot or commercialization strategy is: 1 – very inadequate; 2 – inadequate; 3 – adequate; 4 – notably good; or 5 – exceptionally good.**

**Reviewer H3 (Rating 2)**

No real discussion on equipment will be needed and if and where it can be obtained. There are plans for a SWD or Class II well. This project will require a Class I well.

- The proposed budget is comprehensive and sufficient relative to the outlined work and the timetable: 1 – not sufficient; 2 – possibly sufficient; 3 – likely sufficient; 4 – most likely sufficient; or 5 – certainly sufficient.**

**Reviewer H3 (Rating 3)**

The evaluation of this budget is beyond this reviewer’s expertise.

- 6. The appropriate strategic partnerships are in place for short and long term plans to be successful: 1 – very limited; 2 – limited; 3 – adequate; 4 – better than average; or 5 – exceptional.**

**Reviewer H3 (Rating 3)**

There is a strong partnership with oil and gas industry experience, but then the focus is on fertilizer production. There is vague or limited partnership in the actual extraction process or facility management.

- 7. The likelihood that the project approach (time & budget) will achieve its technical and market goals is: 1 – not achievable; 2 – possibly achievable; 3 – likely achievable; 4 – most likely achievable; or 5 – certainly achievable.**

**Reviewer H3 (Rating 3)**

Still many unknowns and much is still research. The process and timing is reliant on the development of a Class II well. However a Class I well is needed which has a longer permitting process.

- 8. The scientific and/or technical contribution of the proposed work to specifically address Clean Sustainable Energy Authority goals of impacting technology used in North Dakota's energy industries will likely be: 1 – extremely small; 2 – small; 3 – significant; 4 – very significant; or 5 – extremely significant.**

**Reviewer H3 (Rating 4)**

While the scientific and technology achievements could potentially be significant to the state, the discussed process is not clean energy.

- 9. The project management plan, including budgeting projections, partner connections and well-defined milestone chart is: 1 – very inadequate; 2 – inadequate; 3 – adequate; 4 – notably good; or 5 – exceptionally good.**

**Reviewer H3 (Rating 3)**

Partnerships and milestones for the first phase of the project are well defined. Long-term partnerships and milestones are vague. No backup plan if milestones are not met.

- 10. The background and experience of the project principals with regards to technical qualifications and competence is: 1 – very limited; 2 – limited; 3 – adequate; 4 – better than average; or 5 – exceptional.**

**Reviewer H3 (Rating 3)**

Since this is the first of its kind operation, it is difficult to judge qualifications.

---

**Section C. Overall Comments and Recommendations:**

**Please comment in a general way about the merits and flaws of the proposed project and make a recommendation whether or not the project is technically sound.**

**Reviewer H3**

While the production of fertilizer from produced water could be a valuable asset to the state, it is not clean energy. It should seek funding from another source.

May 19, 2023

Clean Sustainable Energy Authority  
North Dakota Industrial Commission  
600 East Boulevard Ave  
Bismarck, ND 58505

**Re: HydroStrat application for Clean Sustainable Energy Authority grant.**

HydroStrat is submitting the attached application for grant funds under the North Dakota Industrial Commission's Clean Sustainable Energy Authority program.

Every day in North Dakota, greater than \$10 million worth of minerals, which are found naturally in oil and gas produced water, are injected into disposal wells and left uncaptured. These minerals include, but are not limited to various lithium, barium, potassium, strontium, magnesium, and fluorine compounds.

HydroStrat's mission is to provide innovative solutions to long-term water and energy challenges by using a holistic and sustainable approach to the use and conservation of natural resources.

HydroStrat will approach this unique problem with expert geologic knowledge that has identified disposal zones that are 10-50 times more prolific than the average Bakken disposal well. These next generation disposal wells will be used to consolidate large volumes of Bakken produced water in order to efficiently extract critical minerals, deemed essential to both North Dakota and the United States.

These various mineral compounds will be used to create fertilizers, chemical feedstocks, lithium-ion batteries, ceramics, and other advanced materials. HydroStrat intends to reclaim, reuse, and recycle as much water as possible throughout this process with the long-term goal of 100% capture and 0% disposal.

If you have any questions or require additional information, please do not hesitate to contact us.

Sincerely,

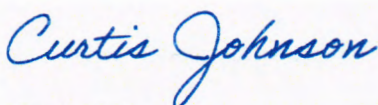

Curtis Johnson  
CEO & Founder

Clean Sustainable Energy Authority  

---

North Dakota Industrial Commission

## Application

**Project Title:**

Enhancement of Energy Infrastructure to Enable Sustainable Resource Management, Stimulate Innovation, and Secure Domestic Supply of Critical Minerals

**Applicant:**

HydroStrat GP, LLC

**Date of Application:**

May 19, 2023

**Amount of Grant Request:**

\$10,000,000

**Total Amount of Proposed Project:**

\$2,300,000,000

**Duration of Project:**

Pilot Program: 2-3 years

Commercial Facility: 5-7 years

**Point of Contact (POC):**

Curtis Johnson

**POC Telephone:**

(281) 684-9134

**POC Email:**

curtis@hydrostrat.com

**POC Address:**

912 Cohn St, Houston, TX 77007

## TABLE OF CONTENTS

<b>Abstract</b>	<b>4</b>
<b>Project Description</b>	<b>5</b>
<b>Standards of Success</b>	<b>13</b>
<b>Background/Qualifications</b>	<b>16</b>
<b>Management</b>	<b>18</b>
<b>Timetable</b>	<b>18</b>
<b>Budget</b>	<b>20</b>
<b>Confidential Information</b>	<b>20</b>
<b>Patents/Rights to Technical Data</b>	<b>20</b>
<b>State Programs and Incentives</b>	<b>20</b>
<b>Letters of Support</b>	<b>Appendix A</b>
<b>Confidentiality Request</b>	<b>Appendix B</b>
<b>Confidential Information</b>	<b>Appendix C</b>
<b>Business Plan</b>	<b>Appendix D</b>
<b>Historical Financial Statements</b>	<b>Appendix E</b>
<b>Budgeted Projections</b>	<b>Appendix F</b>
<b>Tax Liability Statement</b>	<b>Appendix G</b>

## **ABSTRACT**

### **Objective:**

The ultimate objective of this project is to provide a cleaner and more sustainable alternative to traditional salt water disposal (SWD) for the oil and gas industry while creating a beneficial use from an existing waste stream. This will be accomplished by first aggregating large volumes of produced water, then extracting potentially dozens of mineral compounds for commercial use, and finally reclaiming the remaining fresh water for industrial and agricultural applications. If the project is successful, the total investment could exceed \$2 billion over 7 years.

The overall project is complex in nature and will require significant follow-on investment upon the achievement of major milestones which advance the project towards an integrated commercialization path. For the purposes of this particular application, we will focus primarily on the first two phases of our mineral extraction pilot program. This specific project will design and construct a pilot facility capable of platforming and developing both existing and emerging mineral extraction technologies with the goal of achieving commercial viability with oilfield brines in North Dakota. HydroStrat plans to selectively partner with successful technology companies with the intent to build a commercial scale mineral extraction facility.

Many early-stage extraction technologies show promise in a laboratory, but encounter challenges with commercialization due to the burdensome task of scaling up their technology. HydroStrat's proposed pilot facility will alleviate these prohibitive barriers for aspiring technology companies by offering access to required power, large volumes of produced water, pre-treatment of produced water, product storage, and disposal of effluents at fractions of their typical cost. In addition, HydroStrat will provide facilities management, skilled labor, and the expertise to operate company equipment and oversee third party testing. As a result, the platform will attract researchers, entrepreneurs, technology companies, and investors from all over the world to North Dakota.

### **Expected Results:**

This project will result in the construction and operation of a state-of-the-art research facility that will be the first of its kind and is capable of long-term commercial mineral extraction. No other facility in the world will have the same research capabilities and capacity to develop a multitude of various extraction technologies simultaneously. This facility's primary purpose will be to act as a hub for innovation, investment, and development of mineral extraction technologies. The pilot facility will be designed to both repurpose existing "off the shelf" technologies and support emerging technologies on their path to achieving commercial viability.

Moreover, this project will expand the public knowledge of the extent and value of mineral resources within produced water across the Williston Basin. An assessment will be completed with cooperation from the Energy and Environmental Research Council (EERC) and its findings will be documented.



A successful pilot will have proven the value of undeveloped minerals (PUD Mineral Reserves) in Bakken produced water and developed the necessary technologies to extract those minerals, laying the groundwork for further investment of a large-scale and commercial mineral extraction refinery in North Dakota.

**Duration:**

The first two phases of development for the mineral extraction pilot facility are planned to progress over 24 to 36 months from the time that funds are deployed. The third phase is expected to last an additional 12 to 18 months. Full scale commercialization is estimated to begin in 5 to 7 years.

**Total Project Cost:**

Total project costs for the mineral extraction pilot facility (phases 1 & 2 only) are expected to be \$32.2 million. We ask that the Clean Sustainable Energy Authority award us \$10 million in grants, or roughly 31% of the cost, and the remainder of the project cost will be supplied in cash from HydroStrat.

**Participants:**

HydroStrat will manage the project with technical and regulatory assistance provided by the Energy and Environmental Research Center (EERC). HydroStrat will partner with Koch Engineered Solutions and Koch Technology Solutions to engineer and design the mineral extraction pilot facility. Additionally, HydroStrat plans to conduct agricultural research in close partnership with the North Dakota Department of Agriculture to understand the use cases for fertilizer production and irrigation using reclaimed water. HydroStrat will also utilize partnerships with various salt water producers, technology companies, qualified contractors, and well-known service providers to further develop the infrastructure, capabilities, and resources to successfully pilot and commercialize a mineral extraction facility in North Dakota.

**PROJECT DESCRIPTION**

**Objectives:**

The objectives of this project are to **A)** display proof of concept for HydroStrat's plans to provide cheaper and safer salt water disposal infrastructure for North Dakota's oil & gas industry, and **B)** pilot a mineral extraction and research facility to determine the relevant economics or a commercial refining facility. This project will aggregate at least 20,000 barrels of produced water per day from strategic partnerships with oil & gas industry leaders to provide the required volumes for the pilot facility. After the mineral extraction technologies have processed the produced water, the effluents will be disposed using a class II injector. Furthermore, the injection well will prove HydroStrat's proprietary disposal



zone, which is expected to offset the escalating water management concerns within the oil and gas provinces of North Dakota.

To prove the prevalence of the intended disposal zone, HydroStrat will drill a stratigraphic test well to record gamma ray, bulk density, density porosity, and resistivity logs over the interval. If the recorded log data and drill cuttings show promise, the well will be cased, cemented, and completed in order to perform a step-rate injection test. The results of this injection test will serve as empirical evidence of the formation's ability to take large volumes of produced water at low pressures and will further justify HydroStrat's plans for investment into large scale produced water infrastructure. Successful completion of the test well and its facilities will generate access to large volumes of produced water and identify HydroStrat as a profitable enterprise.

This project's objectives include the engineering design of the mineral extraction pilot facility, taking it from FEL-1 to FEL-4. Soon after engineering designs are complete, construction will begin, and mineral extraction operations will commence. At that time, HydroStrat will have secured technology rights and equipment for pre-treatment and extraction of lithium carbonate through its partnerships.

#### **Methodology:**

This project's tasks have been organized into two phases and then further subdivided by similar task requirements and chronological order. Many tasks are independent of each other and will be pursued concurrently. The progression from phase 1 to phase 2 will occur based on the needs of individual and collective technology needs. This means that it is possible to have multiple tasks across both phases at the same time. This flexibility was intentionally added so that promising technologies will be preferentially advanced further and faster.

#### *Mineral Extraction Pilot Phase 1 (Establish Operations)*

1. *Finalize Key Personnel.* The first step after receiving a grant from the Clean Sustainable Energy Authority is to hire key personnel and execute contracts with our partners to lock in stakeholders. HydroStrat will bring on full-time staff with performance-based compensation that is comparable to similar early-stage businesses.
2. *Finalize Location.* HydroStrat has already identified a multitude of suitable areas within a 5-mile radius but is intentionally waiting for CSEA funds to assist with payments to the EERC to further extend HydroStrat's existing knowledge of the regional geology. Together, we will use relevant subsurface mapping and modeling techniques to evaluate and prioritize the already high-graded locations to pinpoint the optimal injection zone.
3. *Secure Land Rights.* Due to the immense potential value of the disposal zone, HydroStrat will use internal and contracted landmen to execute its land leasing and acquisition strategy. This task is imperative to securing our long-term survival by protecting our business from future competitors and potential pore space disputes. Once the acreage is sufficiently held, we will begin any necessary permitting processes.
4. *Permit Class II Injector.* HydroStrat intends to plan and permit a class II injector with adjacent and near-adjacent facilities. The first step in the permitting process, after securing land rights, is to run

geotechnical surveys to understand environmental risks for near surface aquifers. If these test results are agreeable with the North Dakota Department of Mineral Resources, we will finalize engineering plots and plans. Next, we will complete engineering designs for drilling and completions plans. These plans will determine our expected injection capacity and thus how much capacity we need for tanks and pumps at our enhanced SWD facilities.

5. *Permit Mineral Extraction Facility.* The initial engineering design for the mineral extraction pilot facility will be independent of our designs for the class II injector and so this work will begin concurrently. The final design will be dependent on location and expected daily injection capacity. The EERC will also provide guidance and advice on the engineering designs for a pilot facility based on their experiences with their Brine Extraction Storage Test facility. We will work with the EERC and Koch Technology Solutions to meet all state requirements for permitting a treatment facility.
6. *Stratigraphic Test.* As permits are completed, drilling and construction will commence. First, we will break ground on pad construction. Second, we will bring on a rig to drill our stratigraphic test well. If the stratigraphic test is promising, we will case and cement the hole. Then we will perforate the casing over the desired injection intervals and perform a step rate injection test.
7. *Construction.* With a positive step rate test, construction of disposal and mineral extraction facilities will begin immediately. Many components of the facilities are either modular or commonly used and we will have secured access to construction materials prior to attaining positive injection test results.
8. *Contract Negotiations.* Currently and during construction, HydroStrat will continue ongoing discussions with mineral extraction technology companies and energy companies to further secure access to additional extraction technologies and volumes of produced water.
9. *Begin Business Operations.* With the first proprietary disposal well in service, we will begin operating the business and collecting revenues from salt water disposal and mineral extraction service contracts. The expected medium to long term outcome is the formation of several key strategic partnerships that will lead to co-investment and joint venture opportunities with premier businesses.

#### *Mineral Extraction Pilot Phase 2 (Implement Extraction Technologies)*

1. *Best Practices.* Because this will be the only facility of its kind, there will be a learning curve associated to the development of the technologies. After operating for several months, with staffing help from EERC, we will begin to establish processes, procedures, and best practices prior to our high-growth phase.
2. *New Employees.* With the establishment of processes and procedures by our key personnel, we will begin hiring and training new employees to take over responsibilities from EERC and prepare for growth. These future employees will be composed of mostly recent engineering and science graduates from North Dakota universities.
3. *Growth.* Once properly staffed, we will grow the business operations and improve cash flows. We will actively work to grow the business through increasing disposal volumes and signing on new technology companies to the platform program. At this point HydroStrat will be suitable for, and begin the pursuit of, federal Department of Energy grants to expand the business and its facilities.

4. *Expand Facilities.* Phase 1 of the mineral extraction pilot program will be limited by the number of users and throughput of produced water. As we bring on new customers and increase volumes, we will increase the number of skid bays and tanks for pre-treatment of produced water. This expansion will increase our capacity and propel the technical readiness level of technologies.
5. *Data Acquisition.* Once we achieve critical capacity thresholds, technologies will be tested at higher volumes. We will focus on identifying key metrics, data collection, and data analysis to improve the overall multi-stage process. The goal of this task is to gain a thorough understanding of mineral constituents in the produced water, the capital expense of installing modular technologies, the operational costs to extract those minerals, and finally, the economic yields from mineral extraction. We will also assess and begin developing preventive and mitigation strategies for potential hazards that come with commercial scale extraction.
6. *Yield & Purity Standards.* Early production of high-purity products will be in small quantities. The purpose is to test consistency of the finished products while also limiting expenses. This step is not intended to, but could create enough of high-margin products to stockpile and sell in bulk by rail car. Once consistent results are realized, the business' options for expansion become materially significant and wide ranging.
7. *Agricultural Applications.* The future commercial facility will need to be highly efficient and should mitigate costs by utilizing all available revenue streams. It is well-known that fertilizers are highly demanded in North Dakota and fertilizer feedstocks are a viable product of mineral extraction. This task is intended to utilize available and segregated land to prove that our fertilizer products have positive effects on the development of agricultural land. We will use designated plots of land to vigorously test the application of our fertilizers on multiple regional crops and soil types. A separate, but similar, experiment will be performed to test irrigation of regional crops with purified water from HydroStrat's water reclamation process.
8. *Technical Conclusions.* After several months of rigorous research, we will be able to conclude the effectiveness of developing and repurposed technologies. We will perform a comprehensive assessment and report our findings to investors and the Clean Sustainable Energy Authority.
9. *Financial Conclusions.* Using our technical results as inputs into a financial model, we will analyze and optimize our production plan. This task will determine the decision to advance the project. We will understand the feasibility and requirements of a commercial scale facility. Advancement to phase 3, will include production of some or all of our intended products at pre-commercial volumes, and signify the initial development of markets for those products. This stage will also initiate additional rounds of capitalization to fund the commercial facility with further equity, debt, and state fund contributions to realize the commercial project.

#### **Anticipated Results:**

Our anticipated result for this project is to have a cash flow positive business that demonstrates our concept for a cheaper and environmentally friendlier salt water disposal alternative for North Dakota's oil & gas industry. The stratigraphic test and subsequent step rate injection test will prove the prolific nature of our proprietary disposal zone and encourage investment into produced water infrastructure. Upon conclusion of phase 2 of our mineral extraction pilot program, we will have defined economic

thresholds and technical feasibility for a series of technologies to be chosen for implementation into a future large-scale commercial facility.

This project will also result in an assessment of the state's mineral resources contained within Bakken and Three Forks produced water. We anticipate using leased or acquired land in partnership with the North Dakota Department of Agriculture to test fertilizers and irrigation of crops using reclaimed water. We expect results to show no harmful side effects from use of our purified water on agricultural land. As applicable, HydroStrat will begin filing process patents on intellectual property gained from this project's research and development efforts.

The project results will support CSEA's mission to develop and deploy large-scale commercial projects that reduce environmental impacts and increase the sustainability of energy production.

**Facilities:**

This project will have more than sufficient facility access for its research and development efforts. HydroStrat will operate its own laboratory and treatment facilities to handle basic needs and will supplement its more advanced testing and research needs with facilities from the EERC and Koch Technology Solutions (KTS).

Phase 1 of the HydroStrat pilot facility will have an injection capacity of 50,000 barrels per day (BPD) and an initial processing capacity of 200 BPD that will scale up to 2,000 BPD (phase 2) and eventually to 20,000 BPD (phase 3). The rate at which the facility will scale up is dependent on the testing requirements of the platformed technologies. Produced water intake will come through dedicated contracts with minimum water volume commitments.

The pilot facility will have pre-treatment capabilities to filter solids, organics, suspended solids, and alter pH so that each customer has access to treated water in accordance with the standards of their technology. All essential valves, tanks, and pumps will be monitored by a series of sensors through a control room using a supervisory control and data acquisition system (SCADA). Each valve and pump will have automated and manual cutoff controls. There will be a minimum of two employees at the facility during operations in addition to 24-hour surveillance and remote control of critical safety equipment and emergency shutoff.

There will also be a modest laboratory in place to handle our basic operational research requirements in a timely manner, eliminating the need to ship samples long distances that would delay results. The laboratory will be designed based on the needs of the technologies, but will likely include at least a mass spectrometer, gas chromatograph, and X-ray fluorescence machines. These devices are used to measure which elements are present in water samples as well as their concentrations and purity. Our highly technical 4-D water sampling program and exploration for rare-earth minerals will be handled at the EERC labs in Grand Forks.

The EERC has over 254,000 square feet of facilities for technology demonstration, process modeling, and project execution. For over 70 years, the EERC has conducted research, testing, and evaluation of fossil

and renewable fuels, and emission control technologies. The engineering and scientific research staff is equipped with state-of-the-art analytical, modeling, and engineering facilities to address a wide variety of energy, environmental, and mineral resource research topics.

Koch Technology Solutions has decades of experience and hundreds of operating facilities around the world. Their ability to innovate, develop and transfer technology has created long-standing, trusted relationships with its licensing clients around the world. KTS creates preferred partnerships. By leveraging the expertise of their engineers, project managers, and operations experts they can maximize the return on capital investments for manufacturing owners. By partnering with companies in the early stages of chemical process development their team can scale solutions to commercial deployment and deliver the technology to create the next generation of process technologies.

**Resources:**

HydroStrat will utilize and leverage relationships with its strategic partners which include many renowned technical experts, premier contractors, and consultants. Some of which are:

- EERC *Research, development, and advisory services*
- Koch Engineered Solutions *Engineering design for mineral extraction pilot facility*
- Koch Technology Solutions *Lithium extraction and pre-treatment*
- Neset Consulting Service *Planning, permitting, and drilling*
- KLJ *Engineering & construction of disposal facilities*
- Stanley Milam *Inorganic chemistry*
- Cutting Edge Consultants *Regulatory*

**Techniques to Be Used, Their Availability and Capability:**

Many different techniques will be used that vary in availability and capability. The goal of the proposed project is to determine exactly which ones, and in what combinations, can be commercially scaled.

There are several main families of technologies that we intend to explore:

1. *Pre-Treatment of Produced Water.* Pre-treatment of produced water is widely available and already implemented throughout the oilfield. These techniques will remove solids and organics (hydrocarbons and naturally occurring bacteria) from the produced water.
2. *Physical & Chemical Processes.* These physical and chemical processes are well documented and have been implemented at commercial facilities across the U.S. for decades. Some of the processes we aim to utilize include multi-stage flash distillation, extraction using solvents, vacuum crystallization, and pH enhanced precipitation.
3. *Ion Exchange Resins.* Ion exchange technologies are widely used and capable at commercial scales, but have not yet been commercially successful for direct lithium extraction (DLE) of Bakken brines. Most emerging technologies in the lithium extraction space are focused on ion exchange using either absorption or adsorption techniques. The project will help develop these technologies for a specific application to Bakken brine.

4. *Membrane Filtration.* Membrane filtration is commonly used in water treatment and desalination at commercial volumes around the globe. The scientific field of membrane filtration is rapidly improving its selective extraction capabilities and continuously reducing material costs through innovation. Several of the filtration techniques HydroStrat will apply include reverse osmosis, nanofiltration, and bipolar membrane electrodialysis.
5. *Electrolysis.* Electrolysis is adopted at most desalination plants and many chemical refineries for its thorough capability to remove dissolved salts from water. This process uses an indiscriminate desalination technique and would be applied in HydroStrat's future desalination efforts.

#### **Environmental and Economic Impacts while Project is Underway:**

*Environmental Impacts.* In reference to our tasks laid out in the methodology section above, there will be no environmental impact during the phase 1 tasks 1-5, which are limited to engineering design, planning, and permitting. Environmental impacts during phase 1, tasks 6-7, will be minor and restricted to the effects of typical wellsite construction, steel warehouse construction, and drilling of the stratigraphic test well. Little to no environmental impacts are expected during operations of the class II injector and mineral extraction pilot facilities. All facilities will meet state and federal environmental standards of prevention, containment, and ability for remediation. Subsurface disposal zones will experience minimal pressures during injection and will be within the maximum allowable injection pressure (MAIP) to be supported by a step rate injection test.

*Economic Impacts.* North Dakota contractors will be used for planning, permitting, drilling, and construction. The EERC, in addition to several future North Dakotan employees, will run the maintenance and scientific research of the mineral extraction pilot facility. Altogether, approximately \$32.2 million will be spent in North Dakota on this project through phases 1 & 2.

#### **Ultimate Technological and Economic Impacts:**

*Ultimate Technological Impact.* Initial technological impacts will be achieved following completion of the proposed project. These impacts will include the advancement of mineral extraction technologies, technical applications for fertilizer production and consumption, and reclamation of produced water for industrial and agricultural use. Ultimate technological impacts will continue into the future as new technologies are platformed and developed at the project's research laboratory. The research and development laboratory will continue developing new technology throughout commercial operations with the intention of improving existing processes as well as discovering new modular applications to bolt onto the future commercial facility. When there are no scheduling conflicts with private research initiatives, the laboratory will be made available to public, state, and federal research initiatives.

*Ultimate Economic Impact.* The overall project provides a game-changing opportunity for substantial economic development in North Dakota that could exceed \$1.6 billion in invested growth capital. The ultimate investment for a full-scale refining facility and its associated infrastructure needs is anticipated to cost approximately \$2.3 billion over 10 years. Over 90% of invested dollars will go directly towards

North Dakota infrastructure, high-paying jobs, real-estate development, and energy sustainability. Projected economic impacts at full scale include:

- Over 100 direct full-time jobs created during construction of commercial facilities and pipelines.
- 200-400 direct full-time jobs to facilitate long-term operation of commercial-scale facilities.
- Over \$1 billion annually in new revenue streams from mineral extraction.
- Over \$10 million annually in local and state tax revenues.
- Approximately \$45 million per year in disposal cost savings for oil and gas producers.
- Approximately \$365 million per year in drilling cost savings for oil and gas producers.

**Why the Project is Needed:**

This project is needed to provide a cleaner and more sustainable alternative to traditional salt water disposal (SWD) for the oil and gas industry while creating a beneficial use from an existing waste stream that will additionally fortify the domestic supply of critical minerals in the United States.

The oil & gas industry is facing escalating produced water management concerns. Production volumes are increasing, water-to-oil ratios are rising, and economic salt water disposal zones are becoming challenging to source. Current injection zones are showing early signs of potentially dangerous levels of overpressure. These zones are beginning to inject slower, are filling up faster, and are holding less volume. High pressures in the Dakota group have already created hundreds of millions of dollars in unnecessary costs for oil and gas producers due to additional strings of intermediate casing across the over-pressured intervals. The combination of these issues will become a difficult challenge for the industry in the near future. North Dakota needs solutions that bring new and better reservoir for disposal, but also solutions to reduce overall disposal volumes. One such solution is to capture valuable minerals from the waste stream which simplifies the process to reclaim and recycle the produced water. This project is expected to substantially relieve near-term disposal challenges while also creating a significant reduction in overall disposal volumes over the long-term.

The United States consumption of critical and rare earth minerals is reliant on imports from nations with high geopolitical risk. These nations and businesses are either heavily influenced or owned by China and Russia. Currently, the U.S. only produces about 5% of the lithium carbonate that it consumes annually. Traditional lithium production methods are water intensive, time consuming, and damaging to the environment, which is not only expensive, but difficult to accomplish from a regulatory standpoint. What we offer is an alternative process that can handle large volumes, scale up fast, and is cleaner than traditional pit mining or evaporation ponds. A successful project means HydroStrat can significantly increase the availability of domestic supplies of critical minerals which enhances our national security and reduces supply constraints.

The COVID-19 pandemic exposed a breakdown of U.S. international supply chains which created regional shortages and historically high fertilizer prices in North Dakota. North Dakota's agriculture industry imports much of its fertilizers today, but HydroStrat aims to provide chemical feedstocks to attract a regional fertilizer manufacturer which will create more competitive pricing. The production of

these feedstocks will reduce the relative salinity of produced water, making it easier to extract fresh water which could ideally be used to irrigate crops.

Recent water shortages and droughts in North Dakota strained available resources, pitting farmers and energy industry operators against each other. These two industries make up the overwhelming majority of business in North Dakota and would greatly benefit from a meaningful increase in water supply. According to the National Drought Mitigation Center, water shortages are expected to increase in frequency and severity over the next several decades. HydroStrat could theoretically deliver enough water to satisfy the energy industry's forecasted needs, offsetting their use of fresh water aquifers and reservoirs, and directly increasing water availability for agriculture, municipalities, and other industries.

### **STANDARDS OF SUCCESS**

#### **Reduced Emissions and Environmental Impacts:**

To improve the economics of known mineral extraction processes, large volumes of brine must be aggregated safely and efficiently to a central facility. Utilization of next generation salt water disposal (SWD) wells and pipeline transportation of up to 1 million barrels per day (BPD) of produced water will reduce emissions, spills, and overall environmental impacts. Furthermore, HydroStrat intends to review the recommendations made through the EERC iPipe program and will either use or exceed these recommendations when considering construction materials and monitoring systems.

Pipeline transportation of brine will reduce emissions by eliminating the need for hundreds of trucks on North Dakota highways, which in turn will reduce the consumption of diesel and the emissions associated with exhaust. An added benefit of having less trucks on the road will be a significant reduction in the risk of small spills which could potentially go unreported.

HydroStrat's next generation of highly efficient SWD wells will dramatically reduce the total number of injectors needed to satisfy oil and gas operations, further reducing diesel consumption used for drilling and completions. These next generation SWD wells will prevent future overpressure hazards in the Dakota formations and alleviate existing over-pressured zones that inhibit oil and gas development.

Each of HydroStrat's next generation SWD wells will eliminate the future need for 10 typical SWD wells, therefore reducing the environmental footprint at the surface by a factor of 10. HydroStrat's commercial refining facility will have the initial capacity to reclaim and recycle 250,000 BPD of produced water, effectively displacing 50 typical SWD wells, and reducing the overall environmental footprint of the oil and gas industry. Eventually, the commercial facility could have a throughput capacity of 1,000,000 BPD which could displace 200 typical SWD wells.

#### **Increased Energy Sustainability:**

Current development and future production of oil and gas from the Bakken region of North Dakota is hindered by increasingly large volumes of produced water with rapidly diminishing disposal options that



meet both safety and economic criteria. HydroStrat's enhanced SWD designs will reduce capital and operational costs for oil and gas producers. This will lead to increased production and unlock previously uneconomic development. In turn, this transition will promote long-term energy sustainability for North Dakota and the United States.

For perspective, if HydroStrat achieves its intended scale of 500,000 BPD, producers could save approximately \$45 million per year in disposal costs. At current rig counts and drilling rates, HydroStrat could eventually save oil producers \$365+ million per year in capital costs by reducing overpressure in Inyan Kara zones near their future development.

At these same commercial levels, HydroStrat is expecting to produce 8,000+ metric tons of lithium carbonate per year which is roughly double the current U.S. domestic production and only 5% of current U.S. demand. Lithium carbonate is an essential component for the lithium-ion batteries used in power storage and electric vehicles. An increase in domestic supply will offset imports and satisfy a portion of domestic demand at a discounted transportation and taxable rate. The cost savings for domestic battery manufacturers and consumers will help reduce the cost of renewable energy and provide a more diverse energy grid with lower emissions.

#### **Value to North Dakota:**

By enhancing produced water disposal efficiencies, the State of North Dakota will be expanding and extending the value provided by the oil and gas industry to the state and its citizens. A developed connection between the energy industry and alternative critical minerals will assist in increasing the industry's long-term viability and license to operate in North Dakota. HydroStrat can also provide a means to increase operator's ESG scores, thus improving their image to citizens of North Dakota.

The fully commercialized extraction facility will generate products derived from critical minerals that will spur economic growth and attract new industries to the state. Tesla is just one example of a potential business that would bring new facilities to North Dakota. Once sufficient quantities of critical minerals are available, economical, and in a single location, businesses will find North Dakota an attractive location for investment.

Other potential new industries for North Dakota include fertilizer production and agricultural irrigation. HydroStrat will produce chemical feedstocks and mineral compounds to fuel the development of a regional fertilizer industry that operates in North Dakota. Commercialization of HydroStrat products will also generate a new source of low TDS water for industrial and agricultural applications, eliminating competition for fresh water sources within the state.

HydroStrat will continue to create value to North Dakota through taxes. HydroStrat will generate significant tax revenues through direct avenues such as property tax, income tax, and sales tax. Tax revenues will also increase indirectly through sustained oil and gas development as a result of the improved viability of previously non-economic acreage due to a reduction in their capital and operational costs.

### **Public and Private Use of Project's Results:**

Several of our research efforts will become publicly available shortly after the timeframe of this project. These publicly available efforts will include a 4D water sampling program led by EERC, an agricultural study to test for effects on crops by recycled produced water, and open laboratory access granted to state institutions for future research directly or indirectly related to the project.

Right now, the EERC has identified roughly 97% of constituents in Bakken produced water but the remaining 3% is left unknown. We will attempt to identify these low-concentration constituents through a series of extractions and re-concentrations in an effort to identify rare earth minerals and other highly valuable minerals that are not easily detectable with standard laboratory processes.

Most water samples are comingled, meaning that they contain produced water from many different wells, and the contribution of those wells will change over time as production slows. This poses a challenge for understanding the long-term proven reserves of the basin. In coordination with the EERC, we will oversee a 4D sampling program that will test produced water at varying geographic locations with varying frequency and varying sample collection points through time. This series of tests will help us understand the chemical changes that occur from reservoir to wellhead to separation tanks to disposal wells. There is potential mineral value being lost early in the separation process, but a test of this nature has never been attempted or quantified.

The agricultural study will require many partial acres of test plots for each type of crop and with each soil type for every region of the state. The results of this test will determine if large volumes of treated produced water can be safely recycled and reused for irrigation. Our results will be made public through PhD candidate research and doctoral theses.

Other projects will remain privately held as proprietary information. We anticipate private sector technology companies, research co-ops, certain university research, federal government agencies, and financial investors to use the project's facilities for their proprietary research. The HydroStrat facility will be instrumental in the creation of a new technology hub for North Dakota and as such it will need to protect the intellectual property of its customers. HydroStrat itself will also maintain the rights to any patentable technology or process that is developed with private funds.

### **Enhancement of Research and Development of Clean Sustainable Technologies:**

HydroStrat's unique mineral extraction pilot facility will operate as a technology platform that will not only reduce costs for emerging and developing technologies, but also provide the marketplace for their successful technology. Any and all tangible technologies that come through our platform will have the opportunity to license their equipment at our commercial facility.

Other companies have created, or are trying to create mineral extraction facilities, but they are limited in scope and only apply to niche market conditions. Our mineral extraction facility will be the only laboratory in the world to offer dozens of skid bays with access to produced water, pre-treatment of water, power, product storage, and disposal. The abundance of skid bays affords the capability to test

dozens of different technologies in varying combinations, at differing volumes, and all simultaneously. The enhanced flexibility and customization of our facility design will draw in technology companies of all sizes to pursue further development of their products and investors will eagerly pursue rapidly advancing technologies.

Another enhancement of research and development will be through our partnership with the North Dakota Department of Agriculture. We will work with North Dakota universities and government agencies to design and implement experiments using fertilizers and reclaimed fresh water on test plots of North Dakota crops. If we can show that our products are safe for farmers then new sustainable agricultural technologies will be implemented at a commercial scale.

Many processes used in mineral extraction will require cooling and reheating the brine solution. We intend to implement low temperature geothermal energy for direct heat exchange, as well as several opportunities to capture waste heat. We will partner with geothermal energy companies where applicable.

**Preservation and Creation of Jobs:**

This project will both preserve and create oil and gas jobs by extending the economic life of the existing assets and unlocking new acreage that was previously uneconomic. These jobs will be the direct result of cost savings provided to oil and gas producers by HydroStrat's more efficient disposal process. This will assist in stabilizing the North Dakota oil and gas industry from low commodity price environments.

This project's operations will generate dozens of new high-paying jobs that require science, engineering, operations, marketing, supply chain, finance, and accounting professionals. We expect to employ 300+ people in North Dakota with our full-scale commercial facility and will be equivalent in throughput to the sixth largest refinery in the United States. A commercial facility of this size will have a trickling effect that will draw more service jobs to the state to assist the business and its employees.

**BACKGROUNDS / QUALIFICATIONS**

**Summary:**

We are a company who takes a holistic approach to business and are led by a management team with over 50 years of experience in oil & gas exploration and production. We have a wide range of expertise and skillsets that make us uniquely capable for solving complex and long-term problems in the U.S. energy, environmental, and mineral production industries.

We possess both the technical expertise as well as leadership experience to execute this project. Many members of our team have previously held executive and/or board positions for large publicly traded organizations. Their successful careers and highly regarded reputations give us access to important contacts within the energy industry and large financial institutions.

**Management Team:**



**Curtis Johnson, CEO & Founder**

Previously Geologist of Oasis Petroleum, 7 years SWD experience, 11 years geology experience, 11 years oilfield experience, MBA from Rice University, M.S. in Geology from Rice University, B.S. in Geology from Lamar University, Licensed Professional Geologist in Texas since 2016



**David Pitts, CFO & Co-Founder**

Previously CFO of Carrizo Oil & Gas, Previously Audit Partner of Ernst & Young LLP, 30+ years of oil and gas experience, 30+ years of accounting and finance experience, 10 years oil and gas company executive leadership, B.S. in Accounting and Business from Southwest Baptist University, Licensed CPA in Texas



**Michael Thelen, COO & Co-Founder**

Previously Sr Reservoir Engineer and Sr Completions Engineer of Oasis Petroleum, 16 years of oilfield experience, 7 years of service company experience, 9 years E&P operator experience, B.S. Petroleum Engineering from The University of Texas at Austin, Licensed Professional Engineer in Texas since 2013

**Advisory Board:**



**Larry McVay, Advisor & Steering Committee**

Texas Tech - Mechanical Engineering 1970, VP Operations & HSE at BP from 2000-2003, COO of TNK-BP from 2003-2006, Principal of Edgewater Energy LLC, Director of Praxair/Linde 2008-Current, Previously Director at Callon Petroleum



**Scott Urban, Advisor & Steering Committee**

BS & MS Earth Science from Bowling Green State University - 1975 & 1977, Stanford Executive Program – 1995, Executive at BP/Amoco – 1977-2005, Edgewater Energy LLC Partner, Pioneer Energy Services board member, Previously Noble Energy board member, Previously Noble Lead Independent Director



**Andy Houser, Advisor & Steering Committee**

Texas A&M – Architecture/Civil – 1979, Darden Executive Program 1998, VP International at Kerr-McGee 2000-2002, VP Marketing at Kerr-McGee 2002-2005, VP Bus. Dev. at Kerr-McGee 2005-2006, VP Operations at Remora Energy 2007-2011, CEO EF Energy 2011-2015, Independent Consultant 2015-Present



**Billy McLucas, Advisor & Co-Founder**

Managing Partner & Founder - WPM Capital, Executive Chairman of Axial Global. Previously Associate of Investment Banking, Simmons & Co. International, 13 years of corporate finance experience, 15 years of oilfield experience, MBA and B.A. from Rice University

## **MANAGEMENT**

The executive team and operations management will run the facility in conjunction with the EERC. Facility employees will be hired and trained with help from EERC personnel. Management will hire EOS Worldwide to help implement the Entrepreneurial Operating System (EOS), which has been used for decades and is well proven for private companies of 10-500 employees. Their consultant will help the executive team create initial protocols and re-evaluate quarterly progress for the first two years. Executives will train employees and vendors on how to use our system. The EOS model provides a framework for how management and employees can communicate as a team.

Additionally, we will implement Key Performance Indicators (KPIs) to track our progress and make quarterly reports. Our board of advisors and our board of directors will meet quarterly to review KPIs, general progress, and set goals for the business. All executive salaries and bonuses will be tied to performance. All expenditures greater than \$100,000 will require approval from the CFO. All expenditures greater than \$500,000 will require approval from the CEO. All expenditures greater than \$3,000,000 will require approval from the board of directors.

Equity and grant funds will only be spent on approved tasks which will first require that certain milestones be met. These milestones will be finalized by equity partners but are currently as follows:

1. Availability of land acquisition and leasing rights.
2. Permit class II injector.
3. Stratigraphic test success.
4. Secured commitments for produced water.
5. Engineering design of mineral extraction pilot facility meets environmental standards.
6. Cost estimates for pilot facility are acceptable.
7. Secure contracts for mineral extraction technology companies.
8. Build phase 1 of pilot facility.
9. Financial and or technical success before spending to expand into phase 2.

## **TIMETABLE**

Our estimated project schedule is based on numbers of months and starts when our capital is deployed. We will report regular updates to CSEA on a quarterly basis and provide additional reports upon completion of major milestones.



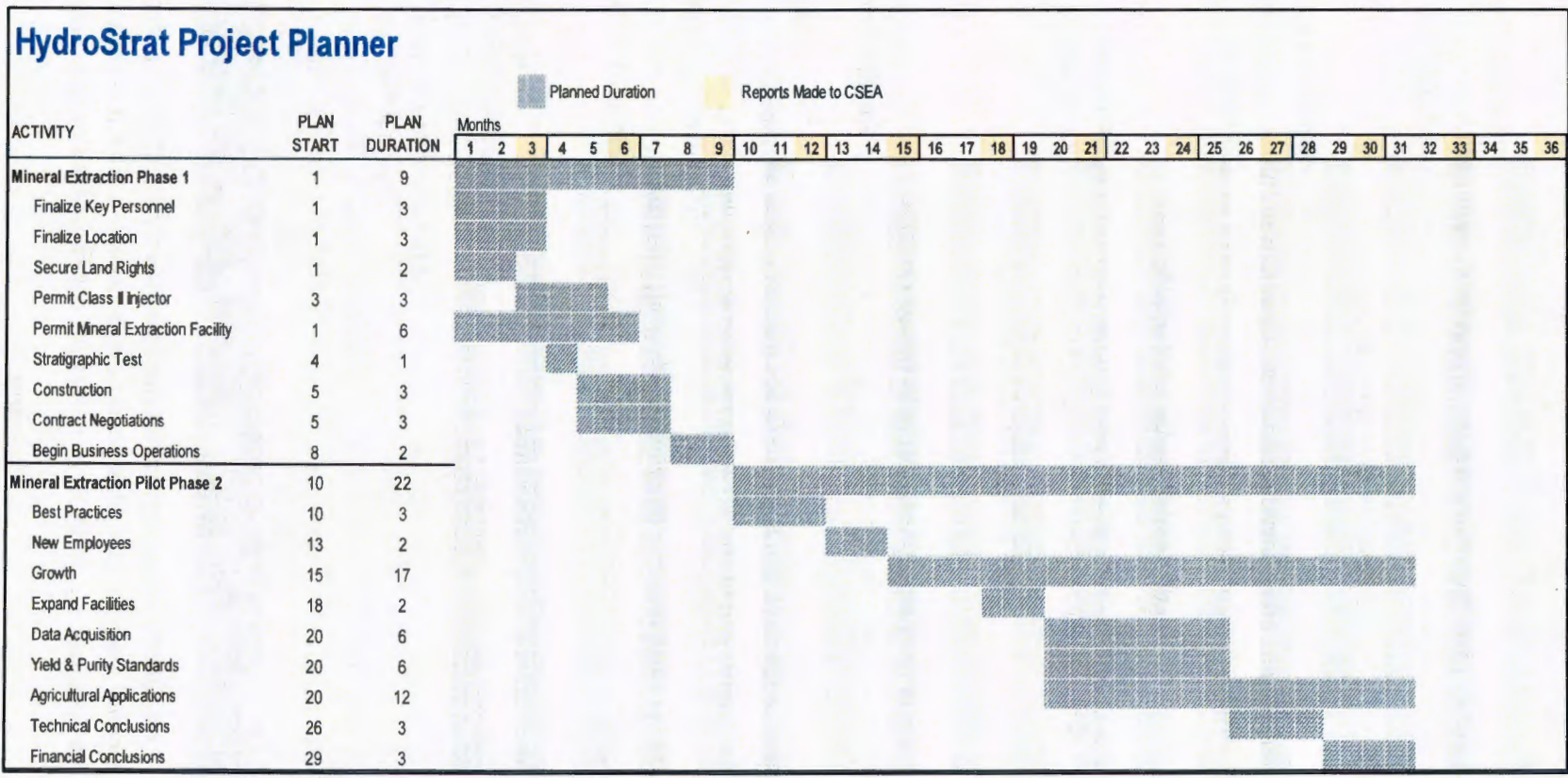

## BUDGET

Please note that the following proposed budget is not all-inclusive. For simplicity, we are only showing the associated tasks that we are requesting financial assistance for and have rounded the figures to the nearest \$50,000. The complete and detailed budget is attached to the appendices.

Task	Project Associated Expense	NDIC Grant	Applicant's Share (Cash)	Total
1.2	Geologic Characterization	\$250,000	\$1,500,000	\$1,750,000
N/A	Produced Water Characterization	\$325,000	\$325,000	\$650,000
1.5	Facility Design & Advisory Support	\$1,000,000	\$1,000,000	\$2,000,000
1.6	Stratigraphic Test	\$750,000	\$750,000	\$1,500,000
1.7	Pilot Facility Construction	\$4,000,000	\$4,000,000	\$8,000,000
1.9 - 2.3	Facility Operations	\$2,075,000	\$2,075,000	\$4,150,000
2.4	Facility Expansion	\$1,600,000	\$2,400,000	\$4,000,000
	<b>Total</b>	<b>\$10,000,000</b>	<b>\$12,050,000</b>	<b>\$22,050,000</b>

The overall proposed budget is \$32.2 million which includes \$10 million from CSEA (31% of total) and \$22.2 million in cash from HydroStrat. The Project Associated Expenses listed above are considered qualified expenses for Clean Sustainable Energy Authority and are tied to tasks from the project methodology section. These itemized expenses are the most vital to HydroStrat's operational plans. While the project will advance with or without CSEA funds, any financial support will help accelerate the projected timeline.

Project cost estimates are derived from proposals, quotes, estimates, comparable public information, and discussions with experts. Estimates already include administrative costs and an additional 10% for contingencies.

## CONFIDENTIAL INFORMATION

This project application contains confidential information. A confidentiality request form is provided in Appendix B. Additional confidential information is contained in Appendices C, D, E, F, & G.

## PATENTS/RIGHTS TO TECHNICAL DATA

HydroStrat intends to file process patents on all successful mineral extraction plans. We would also like to retain proprietary ownership of subsurface reservoir characterization and mineral reserve assessments until the project has concluded.

## STATE PROGRAMS AND INCENTIVES

HydroStrat has not participated in any State programs or incentives to date, but intends to capitalize on future grant and award opportunities with the Oil and Gas Research Council, Department of Commerce, and Department of Agriculture.

**Appendix A**  
**Letters of Support**





May 12, 2023

Mr. Curtis Johnson  
Founder and CEO  
HydroStrat GP, LLC  
912 Cohn St.  
Houston, TX 77007

Dear Mr. Johnson:

**Subject: Letter of support for HydroStrat GP, LLC's Proposal "Enhancement of Energy Infrastructure to Enable Sustainable Resource Management, Stimulate Innovation, and Secure Domestic Supply of Critical Minerals"**

The Energy & Environmental Research Center (EERC) is excited to support HydroStrat GP, LLC (HydroStrat) in its proposal to the North Dakota Industrial Commission (NDIC) Clean Sustainable Energy Authority (CSEA) titled "Enhancement of Energy Infrastructure to Enable Sustainable Resource Management, Stimulate Innovation, and Secure Domestic Supply of Critical Minerals." The proposed scope of work to facilitate the development of a mineral processing facility in North Dakota directly aligns with the NDIC CSEA mission *to enhance the production of clean sustainable energy, to make the state a world leader in the production of clean sustainable energy, and to diversify and grow the state's economy* and the EERC's vision *to lead the world in developing solutions to energy and environmental challenges through innovative science and engineering.*

HydroStrat's unique business model leverages an optimized brine injection zone to allow for high-volume processing of produced water without excessive pressurization of the receiving formation, a condition that has impacted oil and gas development elsewhere in the Williston Basin. The ability to process and inject high volumes of produced water will allow HydroStrat to target the most in-demand and technically recoverable constituents in response to market conditions and extraction technology.

The EERC is pleased to be part of HydroStrat's evaluation of this novel produced water processing facility that could be a long-term, sustainable option for the management of substantial volumes of Bakken produced water, while creating additional value from this in-state resource. The EERC has conducted numerous collaborative projects with industry, state, and federal support and is a leading institution with respect to characterizing Bakken produced water, evaluating various resource recovery and/or treatment options for Williston Basin brines, and modeling the impacts of produced water injection in the Williston Basin.

If selected, the EERC is prepared to negotiate, contract, and execute EERC Proposal No. 2023-0117 titled "North Dakota Mineral Processing Facility Development Support" in support of

Mr. Curtis/2  
May 12, 2023

HydroStrat. Specifically, the EERC will work closely with HydroStrat to support the development of a pilot processing facility for resource recovery of critical minerals from produced water. Specific activities to be conducted by the EERC will include 1) geologic site characterization, stratigraphic well drilling support, and geomodeling and reservoir simulation to define and evaluate water management and prioritize data needs; 2) produced water sampling design and analysis to quantify resources of value in Bakken brines; 3) processing facilities design and operational design for resource recovery from produced water; and 4) facility operation and management support.

We believe that the unique business model pairing an optimized injection zone to a facility for processing high volumes of produced water, and thereby allowing for high resource recovery rates, is an innovative approach that could have long-lasting economic and technological benefits for clean energy advancement for the State of North Dakota. We look forward to collaborating with HydroStrat and NDIC on this exciting critical mineral pilot processing facility. If you have any questions, please contact me by phone at 701-777-5355 or by email at [cgorecki@undeerc.org](mailto:cgorecki@undeerc.org).

Sincerely,

DocuSigned by:  
  
29499751F2B84D7...  
Charlie D. Gorecki  
CEO

CDG/bjr



October 27, 2022

To Potential Investors in HydroStrat,

It is my pleasure as the Director of Economic Development and Finance for the North Dakota Department of Commerce on behalf of the North Dakota Department of Commerce to endorse HydroStrat as a clean energy technology opportunity for investors.

HydroStrat will consolidate hundreds of thousands of barrels of water produced as part of oil and gas extraction in North Dakota, gather this waste stream and process the water for reuse. The recycled water will be made available for agriculture, livestock, industrial use and residential gray water uses.

During the physical and chemical water processing, HydroStrat will extract and purify rare earth minerals. These minerals are critical for the continued manufacturing of batteries for electric vehicles and battery storage for renewable energy sources. This process will help make North Dakota global in the extraction and production of rare earth minerals, reducing our reliance on foreign sources of those minerals.

North Dakota's goal of Carbon Neutrality by 2030 can only be reached through an "all of the above" approach. Our State firmly supports innovation over regulation. An innovative project such as this one proposed by HydroStrat will support the continued exploration and production of the State's abundant energy resources while paving the way for rare earth mineral production supporting battery production for electric batteries.

The Department of Commerce is actively seeking projects that reinforce innovation rather than regulation in our State and thoroughly supports recycling and reuse of any water source as well as extraction of valuable commodities such as rare earth minerals.

Sincerely,

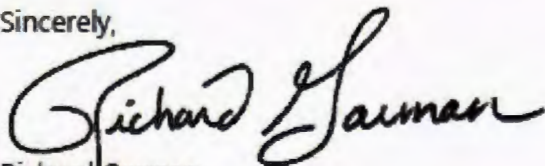

Richard Garman  
Director of Economic Development & Finance  
North Dakota Department of Commerce





**STATE OF NORTH DAKOTA**  
**DEPARTMENT OF AGRICULTURE**  
600 E BOULEVARD AVE, DEPT 602  
BISMARCK, ND 58505-0020

DOUG GOEHRING  
COMMISSIONER

To potential investors in HydroStrat:

It is my pleasure as North Dakota Agriculture Commissioner to endorse HydroStrat as a clean energy technology opportunity for investors.

HydroStrat will reclaim and recycle produced water out of oil and gas production for reuse. The recycled water will be made available for agriculture and industrial use.

During the physical and chemical water processing, HydroStrat will extract and purify rare earth minerals. These minerals are critical for continued manufacturing of batteries for electric vehicles and battery storage for renewable energy sources. Capturing the minerals domestically reduces our reliance on China and boosts national security.

North Dakota is not necessarily a water-constrained state; however, it is in our state's best interest to reclaim, remediate and find innovative uses for water.

North Dakota is the first state in the union to implement carbon sequestration on an industrial scale to support coal generation of electricity; ethanol, biodiesel and biogasoline production from corn; and domestic production of the natural resources of oil and gas production. As Agriculture Commissioner, I am one of the three officials that serve on the North Dakota Industrial Commission. I believe our approach in compliance assistance and empowering people versus enabling them is more productive. We also support recycling and reuse of water sources as well as extraction of valuable commodities such as rare earth materials.

Sincerely,

A handwritten signature in blue ink, appearing to read "Doug Goehring".

Doug Goehring  
Agriculture Commissioner



# NESET

6844 Highway 40, Tioga, ND 58852 701-664-1492

February 7, 2023

To Whom It May Concern,

I understand that HydroStrat is applying for a grant and loan from the Clean Sustainable Energy Authority to help fund the design and construction of a mineral extraction technology pilot facility capable of supporting a wide range of research programs and technological applications to create an innovative and long-term solution to saltwater disposal. Not only will this facility reduce the adverse effects of disposal zone overpressure and reduce costs for oil and gas producers, but it creates an opportunity for the extraction of critical minerals that are key to the United States supply chain.

Production of critical minerals will generate new industries for the State of North Dakota, create jobs and increase tax revenues, all while reducing the environmental footprint of saltwater disposal.

In addition to critical minerals, HydroStrat's facility will also have the potential to produce fertilizer feedstocks that could generate an at-home fertilizer industry, enabling North Dakota's agriculture industry to reduce its reliance on imported fertilizer. Furthermore, HydroStrat will be capable of capturing and recycling produced water for resale to industrial uses, offsetting their use of existing freshwater resources.

Water management is becoming an increasingly significant obstacle to oil and gas production in North Dakota. The Dakota formation, where most saltwater disposal is currently directed, has developed significantly high pressures that raise concerns for operations and environmental priorities. These problems have arisen due to the rapid production growth over the last two decades, which strained the existing processes, and forced many decision-makers into a reactionary state.

HydroStrat will improve these dynamics by focusing on long-term and proactive solutions that utilize their extensive oil and gas experience and profound understanding of North Dakota's geology. This project can quickly become a game changer for the oil and gas industry in North Dakota. For perspective, HydroStrat plans to lease, aggregate, install, and maintain the necessary infrastructure to safely and efficiently process 500,000 barrels of produced water per day or roughly one-third of daily production.

This project is an excellent candidate for the Clean Sustainable Energy Authority's approval and will benefit North Dakota across many industries, including oil and gas, agriculture, and renewables.

Sincerely,

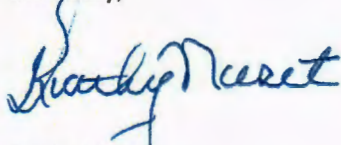

Kathy Neset

President – Neset Consulting Service, Inc.

# NESET

6844 Highway 40, Tioga, ND 58852 701-664-1492

February 7, 2023

Clean Sustainable Energy Authority,

I understand that HydroStrat is applying for a grant and loan from the Clean Sustainable Energy Authority to help fund the design and construction of a mineral extraction technology pilot facility capable of supporting a wide range of research programs and technological applications to create an innovative and long-term solution to saltwater disposal. Not only will this facility reduce the adverse effects of disposal zone overpressure and reduce costs for oil and gas producers, but it creates an opportunity for the extraction of critical minerals that are key to the United States supply chain.

Production of critical minerals will generate new industries for the State of North Dakota, create jobs and increase tax revenues, all while reducing the environmental footprint of saltwater disposal.

In addition to critical minerals, HydroStrat's facility will also have the potential to produce fertilizer feedstocks that could generate an at-home fertilizer industry, enabling North Dakota's agriculture industry to reduce its reliance on imported fertilizer. Furthermore, HydroStrat will be capable of capturing and recycling produced water for resale to industrial uses, offsetting their use of existing freshwater resources.

Water management is becoming an increasingly significant obstacle to oil and gas production in North Dakota. The Dakota formation, where most saltwater disposal is currently directed, has developed significantly high pressures that raise concerns for operations and environmental priorities. These problems have arisen due to the rapid production growth over the last two decades, which strained the existing processes, and forced many decision-makers into a reactionary state.

HydroStrat will improve these dynamics by focusing on long-term and proactive solutions that utilize their extensive oil and gas experience and profound understanding of North Dakota's geology. This project can quickly become a game changer for the oil and gas industry in North Dakota. For perspective, HydroStrat plans to lease, aggregate, install, and maintain the necessary infrastructure to safely and efficiently process 500,000 barrels of produced water per day or roughly one-third of daily production.

This project is an excellent candidate for the Clean Sustainable Energy Authority's approval and will benefit North Dakota across many industries, including oil and gas, agriculture, and renewables.

Sincerely,

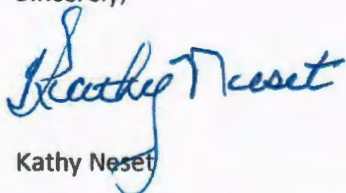

Kathy Neset

President – Neset Consulting Service, Inc.





5/15/2023

Bakken Transload  
8836 62<sup>nd</sup> St NW  
Ross, ND 58776

Subject: Letter of Support for Hydro-Strat's Industrial Processing of Produced Water to extract Lithium

I am writing to express my support for Hydro-Strat's industrial processing business and to highlight the significant strides you have made in extracting a valuable resource while reducing traditional produced water disposal methods, leading the way towards a more sustainable future.

The ability to extract Lithium and other "critical materials" out of what has traditionally been a wastewater product is an important step towards reducing our reliance on geopolitically unstable sources of these materials where growth in demand for these products will outstrip supply. It's also important that minerals like Lithium are extracted in methods that are not detrimental to the environment. Hydro-Strat's processes solve these problems.

By implementing innovative technologies and sustainable practices, Hydro-Strat has significantly reduced the reliance on traditional produced water disposal methods. Your efforts in adopting advanced produced water processing and promoting water recycling will not only reduce water consumption but will also make a positive impact on the Oil & Gas industry in the Bakken formation for years to come.

Hydro-Strat will need to have access to low-cost rail transportation to assist in bringing their "critical materials" products to market. Bakken Transload is uniquely positioned in the Bakken formation and more specifically the Ross/Stanley (North Dakota) area to be able to provide economical transloading operations for Hydro-Strat. Bakken Transload is a premier facility that supports either unit-train or manifest rail transloading of various products such as propane, butane, frac sand, and others.

Your success in balancing profitability and environmental consciousness is a testament to the fact that sustainable practices can be mutually beneficial for businesses and the environment.

In conclusion, I support Hydro-Strat's industrial processing of produced water to extract Lithium and other "critical materials" and commend your leadership in reducing traditional produced water disposal methods. Your commitment to sustainability and technological innovation is inspiring. The strides you have made in this area are invaluable contributions toward building a more sustainable future for our industry, community and beyond.

Sincerely,

A handwritten signature in blue ink, appearing to read "Jim Bennett", is written over a light blue rectangular background.

Jim Bennett  
Chairman/Managing Governor