



# BLUE COMPLY

May 24, 2024

Mr. Reice Haase, Deputy Executive Director  
North Dakota Industrial Commission  
ATTN: Oil and Gas Research Program  
State Capitol – 14<sup>th</sup> Floor  
600 East Boulevard Avenue, Department 405  
Bismarck, ND 58505-0840

Re: Proposal Entitled “Well Site Thief Hatch Methane Detectors – Phase II”

Dear Mr. Haase:

On behalf of Blue Rock Solutions, LLC, dba Blue Comply, we are pleased to submit the original proposal in electronic format and two (2) copies as directed. Also enclosed with the paper copies is the \$100 Application Contribution. It is our hope that the proposed project will result in further development and commercialization of an alternate method to monitor fugitive emissions from oil and gas production site thief hatches that is more accurate, efficient and expedient than the current options available to oil and gas producers.

The Statement of Tax Liability as required:

Blue Rock Solutions, LLC does not have any tax liability owed to the State of North Dakota or any of its political subdivisions.

This transmittal letter represents a binding commitment by Blue Rock Solutions, LLC to complete the project described in this proposal. If you have any questions, please feel free to contact me at 701-361-0403, or by email at [troy@bluecomply.com](mailto:troy@bluecomply.com).

Respectfully submitted,

**BLUE COMPLY**

Troy D. Vareberg, PE

Oil and Gas Research Program  
North Dakota Industrial Commission

## Application

**Project Title:** Well Site Thief Hatch Methane Detectors – Phase II

**Applicant:** Blue Rock Solutions, LLC,  
dba Blue Comply

**Principal Investigators:** Troy D. Vareberg, PE

**Collaborators:** Continental Resources

**Date of Application:** May 24, 2024

**Amount of Request:** \$450,000

**Total Amount of Proposed Project:**

\$900,000

**Duration of Project:** 18 months

**Point of Contact (POC):** Troy D. Vareberg, PE

**POC Telephone:** 701-347-1250

**POC E-Mail Address:** troy@bluecomply.com

**POC Address:** 1331 32<sup>nd</sup> Ave S, Suite 2  
Fargo, ND 58103

## TABLE OF CONTENTS

<b>Abstract</b>	<b>1</b>
<b>Project Description</b>	<b>2</b>
<b>Standards of Success</b>	<b>9</b>
<b>Background/Qualifications</b>	<b>10</b>
<b>Management</b>	<b>13</b>
<b>Budget</b>	<b>14</b>
<b>Confidential Information</b>	<b>15</b>
<b>Patents/Rights to Technical Data</b>	<b>15</b>
<b>Status of Ongoing Projects</b>	<b>15</b>
<b>Appendix A – Letters of Support</b>	<b>16</b>

## ABSTRACT

### Objective:

This project is to further expand the capabilities of an existing methane detection device & associated software created in Phase I (Well Site Thief Hatch Methane Detectors), also known as Industrial Internet-of-Things Methane Sensing Apparatus (IMSA). This technology addresses the largest sources of methane leaks on an oil and gas production site - the storage tank thief hatches.

This shall increase the reliability of gas monitoring, shorten response time for repairs, reduce liability for potential EPA charges and help with the public's perception of the environmental impacts by reducing emissions.

### Expected Results:

The outcome of this project is to achieve commercialization of the IMSA product. This can be accomplished by completing pilot projects with the Producers and fine tuning the product to their needs. Another result of this project is to learn more regarding quantification (estimation of gas being released). This will still be an exploratory idea but we will have narrowed down the pathway to estimating the gas. Evaluating other well site assets that this device could assist producers with detection and monitoring of methane gas emissions.

### Duration:

The project shall last approximately (18) months. This will consist of approximately six (6) months of research and development of design updates based on field testing & Producer comments; (6) months of pilot projects to test design changes and (6) months of implementing changes and scaling up final production tasks.

### Total Project Cost:

The total cost of the project is expected to be \$900,000. The amount requested from the NDIC Oil and Gas Commission is \$450,000.

### Participants:

It is anticipated that all entities previously involved in Phase I Development will participate in the project. These participants include

Blue Rock Solutions, LLC, dba Blue Comply  
Continental Resources, Inc.  
College of Engineering - North Dakota State University  
Methane Emissions Technology Evaluation Center - Colorado State University

## PROJECT DESCRIPTION

### Background:

With the ever-increasing scrutiny of the world's production of Greenhouse Gases (GHGs), industries are placing additional emphasis on following Environmental, Social and Governance (ESG) criteria. From the environmental standpoint, this translates to reductions of GHGs such as carbon dioxide and methane being released into the atmosphere.

In the oil and gas industry, one of the largest sources of GHG emissions stems from methane leaks on the thousands of production sites located throughout the United States. It has been well documented that methane leaks are 28 times more potent than emissions of carbon dioxide.

Prior to 2024, federal, state and local regulations required each production site to be inspected for methane leaks on a quarterly basis. This was accomplished through the utilization of hand-held gas detectors. At that time, actual monitoring techniques or steps were outlined under the Environmental Protection Agency (EPA) Method 21- Determination of Volatile Organic Compound Leaks. This process was very time-consuming and required personnel to be on the production site, in very close proximity to potential hazards.

In 2008, an alternate method of detection was accepted by the EPA which allows the use of Optical Gas Imaging (OGI) cameras in lieu of the hand-held gas detectors. This option allows a camera operator to survey the entire site from a few select "safe" locations in a shorter time span than the previously accepted gas detectors. However, it still requires personnel to physically travel to each site.

Additional alternate methods have been under development over the last few years. These include, but are not limited to stationary OGI cameras, lasers, satellites and networked point detectors. These developments have more recently been given a higher priority due to the passing of the Inflation Reduction Act. A new set of stringent regulations from the EPA has been outlined through the implementation of the Methane Emissions Reduction Program or MERP. Expanding on the previous OOOO and OOOOa (Quad O and Quad Oa), in 2023 the EPA drafted a new rule to Quad Ob for New Source Performance Standards (NSPS) which are rules that apply to well sites built or modified after December 6th, 2022. For oil & gas facilities that have excess of 25,000 tons of CO<sub>2</sub> equivalents, GHG reporting is a requirement under updated Subpart W. It will be the state's responsibility to set a plan that is equal or stronger than these EPA guidelines in Quad Oc for existing well sites built before December 6th, 2022. Transparency will also be targeted through the Super Emitter Program for events that exceed 100 kg/h. This all points to the need for more frequent and automated monitoring technology for oil & gas producers.

### Project:

For this phase of the project, it is our main intent to continue refining the Industrial Internet-of-Things Methane Sensing Apparatus (IMSA) developed under Phase I. Demonstrations of the device to various producers resulted in multiple recommendations to improve the device and more effectively meet the Producers' requirements.

### Prior Work (Phase I):

With the support of previous funding through the NDIC Oil & Gas Research Program, Blue Rock Solutions, LLC (Blue Comply) has spent the last two years finalizing the development and testing of a wireless methane detector with an integral hatch position monitor for oil and gas storage tank thief hatches. Results of these efforts include:

- Final design of wireless methane detection device that utilizes cellular communications.
- Award of US patent device design and utilization.
- Development of web-app dashboard to allow for monitoring and customization of device performance.
- Creation of device calibration procedures.
- Demonstrated the timely detection of methane emissions.
- Production of (25) fully functioning devices for use in field testing and pilot projects.
- Participation in a 12-week third party controlled blind test at the Methane Emission Technology Center (METEC), a nationally recognized facility supported by the oil and gas industry. (Refer to Figure 1)
- Commitment from (2) major oil producers for field testing opportunities.
- Presented final design to multiple producers and received feedback / recommendations on features and capabilities.
- Obtained initial summary reports from Underwriters Laboratories (UL) on feasibility of final design meeting requirements for being listed as Intrinsically Safe and Hazardous Location (CIDI) devices.



Figure 1: Typical Well Site Storage Tank with Device Installed

The following are the milestones that were not fully realized in Phase I:

- Full UL Listing for intrinsically Safe and Hazardous Location applications took longer than expected.
- Field Testing and Pilot Projects with actual Producers were delayed due to an opportunity for third party blind testing at METEC.

## **Objectives:**

The primary objective of Phase II is to build on the Minimum Viable Product developed in Phase I to address recommendations and feedback received from Producers. Individual objectives include:

- Investigate and develop embedded system hardware to include industry standard wireless communication technologies/protocols, (i.e. WirelessHART, Bluetooth, LORAWAN), to allow for direct integration to existing and / or new Producer's SCADA systems.
- Investigate and develop additional power supply options to increase longevity through use of larger and higher capacity batteries, solar recharging and / or newly developed battery technologies.
- Build and deploy updated devices to various Producers as well as perform additional field testing at METEC (Methane Emissions Technology Evaluation Center – Colorado State University).
- Continue pursuit of Underwriters Laboratory and FCC certification for final products.
- Explore other target areas of methane emissions such as gas cooling compressors, compressor buildings, etc.
- Initiate research related to quantification (estimation of gas being released measured as standard cubic feet per minute).

## **Methodology:**

### *Hardware Development*

Modify existing circuit board, device housing assembly, and communication system using engineering optimization methods.

- Update circuit board to be compliant with Underwriters Laboratories initial report for intrinsically safe and hazardous location certification (ICECx/ATEX).
- Revise circuit design to reduce size and allow for more compact / efficient housing options.
- Incorporate network communication functionality into circuit board to directly interface with Producers' existing SCADA systems.
- Collaborate with sensor manufacturers to develop custom assembly to reduce cost and increase performance.

### *Firmware Development*

Provide updates to the firmware to address recommendations from Producers.

- Develop machine learning algorithms to quantify emissions.
- Develop algorithms to differentiate between source point emissions from individual detection devices and larger site-wide emissions from a group of adjacent devices.
- Update algorithm to expand on existing process for determining thief hatch position and monitoring for emissions based on thief hatch position.

### Software Development

Update communications protocol to expand on existing cellular communications and cloud-based technology.

- Update web-based application (dashboard) to expand on existing available information from the device and how it is displayed.
- Incorporate networking capabilities to allow for on-site direct communications of devices with Producer's SCADA systems.

### Pilot Projects and Field Testing

Pilot projects and field testing shall continue in order to gain more feedback from various Producers and verify performance of any modifications.

- Bundling testing and calibration of updated devices shall be performed at North Dakota State University College of Engineering in Fargo, North Dakota.
- Pilot Projects are expected to be completed with the assistance of (2) major Producers in the Williston Basin and the Permian Basin.
- Additional field testing of devices developed under Phase II shall be performed at the Methane Emissions Technology Evaluation Center (METEC) facility at Colorado State University in Fort Collins, CO.

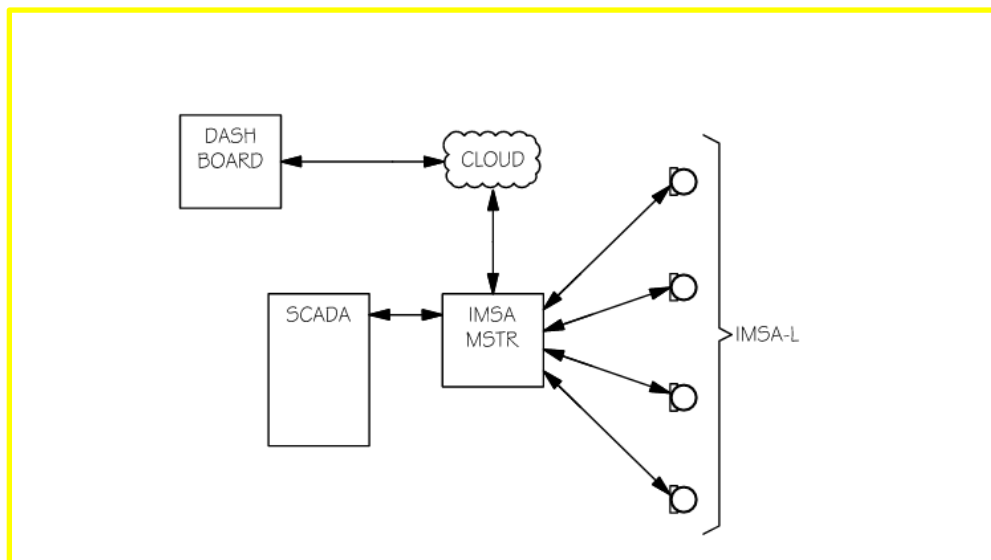

Figure 2: Topology of the proposed methane sensor communications.



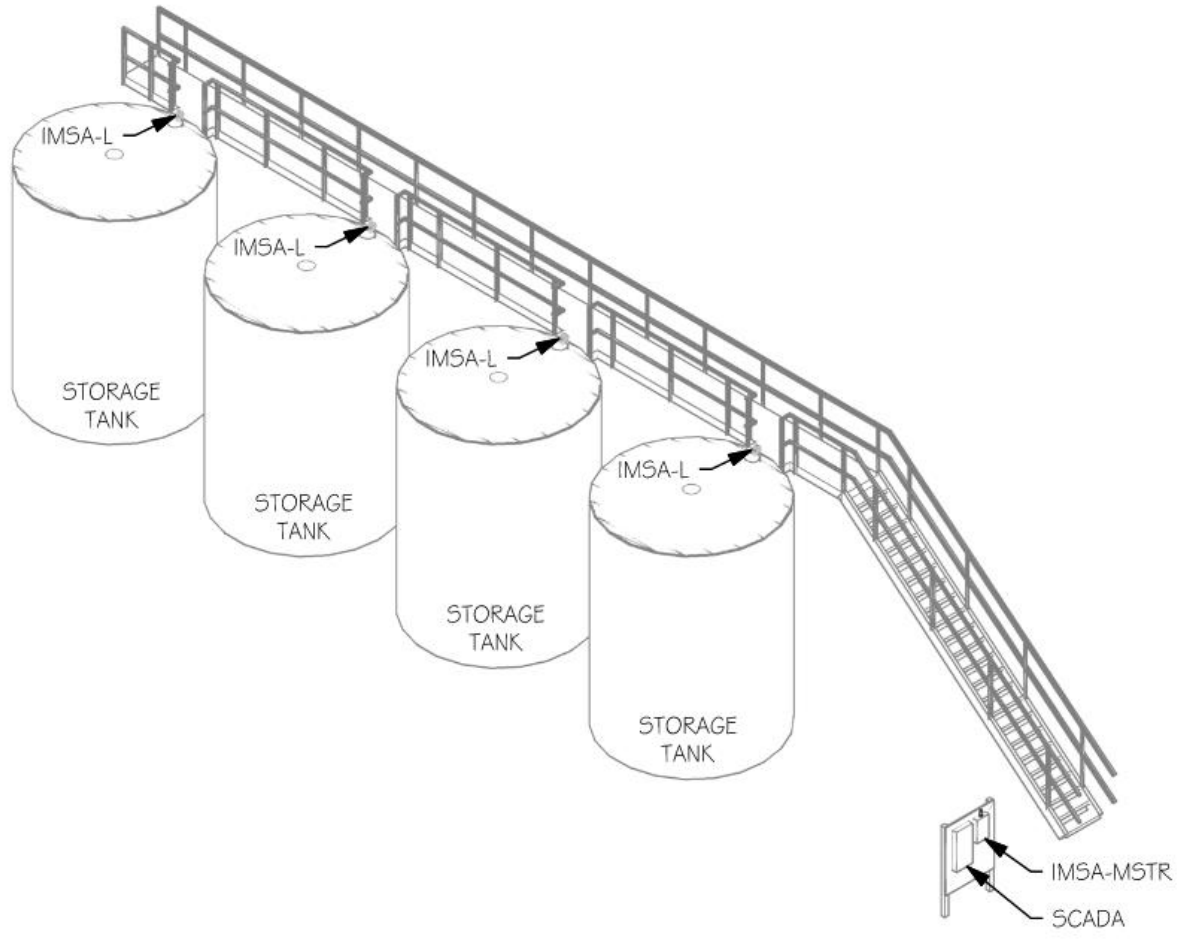

Figure 3: Methane Sensor and Master Controller Layout

**Anticipated Results:**

The goals of this project include:

- Develop a wireless network communications system that allows direct interface with Producer’s SCADA system.
- Optimize power supply selection based on final device configuration.
- Conduct additional field tests to validate updated device capabilities and configuration.
- Demonstration of how the proposed system will detect leaks and emissions at a much faster rate than traditional monitoring and how that will reduce emissions from oil and gas production sites.
- Progress on development of quantification of gas emissions.

**Resources / Facilities:**

Blue Comply currently has an office facility in Fargo, North Dakota and a staff of (4) engineers. In addition, the following resources are planned for use on this project.

Hardware / Software Revisions:	Blue Comply TBD North Dakota Company
Circuit Board Fabrication:	TBD North Dakota Company
Engineering Support:	Vareberg Engineering, Ltd.
Field Testing:	METEC, Fort Collins, Colorado
Pilot Projects:	Continental Resources – 2 Williston Basin sites
Device Testing and Calibration:	NDSU College of Engineering, Fargo, North Dakota Blue Comply

**Techniques to Be Used, Their Availability and Capability:**

Phase II is based on utilizing pre-existing methane detection devices and supplementing with automation and communication capabilities. The basic components are commercially available and already meet anticipated performance specifications. Each newly created device shall be intrinsically safe and shall be suitable for the environment for which they are installed.

**Environmental and Economic Impacts while Project is Underway:**

It is anticipated that there will be little to no environmental or economic impacts during this phase of the project.

**Ultimate Technological and Economic Impacts:**

Automation in the oil and gas production industry is beginning to take hold and is showing great promise for increasing production, safety and reliability. Phase II is an expansion of these capabilities by automating a historically time-consuming process of monitoring gas emissions.

Lessons learned from this phase of the project shall also help accelerate the growth of utilizing additional sensors throughout an entire production site. While localized sensors are not the ultimate answer to tackling the fugitive emission problem, it is another tool for Producers to use in a broader, all-encompassing program. Incorporating the information provided by these sensors into a Producer's SCADA infrastructure can only enhance the reporting efficiency of Greenhouse Gas emissions and reduce Waste Emission Charges.

**Why the Project is Needed:**

This Project is needed to help develop economically and technically feasible alternatives to the existing time consuming and costly options of monitoring for fugitive gas emissions. With constantly increasing pressure from government agencies and the general public, high-level monitoring and control of fugitive emissions will become a necessity. Newly enacted regulations, specifically the Waste Emission Charges, found within the Inflation Reduction Act legislation will be imposing penalties on Producers that do not properly monitor and control fugitive emissions.

## **STANDARDS OF SUCCESS**

With the well-documented detrimental effects of greenhouse gases on the environment, along with the increase in ESG legislation and criteria, any reduction of fugitive emissions from oil well production sites would be considered a success.

As a result of this project, it will be technically feasible to significantly reduce the overall leakage or emissions from each site. Such a reduction will have definite financial benefit for the Producers in both increased revenue and lowered maintenance / remediation costs. Producers could also use the results of this project to expand on the use of “big data” to predict and address failures before they occur.

The successful completion of this project will also help keep the State of North Dakota at the forefront of the US Energy arena and help with the Governor’s goal of carbon neutrality by 2030. Continued development in the areas of gas monitoring, emission control and remediation could have a profound impact in North Dakota, the Bakken and throughout the United States.

With approximately 19,000 active wells currently in North Dakota and plans to more than double that quantity, the devices developed under this Project have the potential of capturing nearly 200,000 tonnes of methane annually. That is equivalent to the removal of nearly 1,000,000 passenger cars from the roads annually.

## BACKGROUND/QUALIFICATIONS

### Blue Comply

Blue Rock Solutions, LLC, dba Blue Comply is a North Dakota company specializing in custom engineering solutions for the energy and industrial sectors. It was founded by the partners of Vareberg Engineering, Ltd. as an entity dedicated to product design and development:

Troy D. Vareberg, PE received his B.S. degree from North Dakota State University (NDSU) in Electrical and Electronics Engineering (1990). He has been involved with electrical design in the built environment since 1985, including (4) years as the primary electrical engineer for the Department of Energy at Ames Laboratory in Ames Iowa. He has been the President of Vareberg Engineering, Ltd. since its inception in 1997. In that time, he been involved in the design of well production sites for the past 17 years. Primarily, design has included power systems and control system wiring for more than 190 well sites throughout the Williston and Powder River Basin. Additionally, his expertise includes the analysis and documentation of more than 600 well sites for electrical deficiencies and arc flash hazards.

Emmy L. Vareberg, PE earned her B.S. degree from North Dakota State University (NDSU) in Industrial Engineering and Management (1993). With over two decades of experience in the design consulting field since 1997, she has continually demonstrated her expertise and leadership. Currently serving as the Vice President of Vareberg Engineering, Ltd., Emmy oversees project management for various endeavors while also handling the day-to-day operations. In addition to her professional responsibilities, she actively contributes to the engineering community as a member of the North Dakota Board of Professional Engineers and Land Surveyors (NDPELS). She remains deeply connected to her alma mater, NDSU, by serving on the College of Engineering Advisory and Advancement Board.

Cooper Bierscheid earned his B.S. degree from North Dakota State University in Manufacturing Engineering. After spending time as a capital project engineer at 3M, he founded his first company, Protosthetics in 2014. He later co-founded Fargo Additive Manufacturing Equipment 3D (FAME 3D) in 2019 which acquired the assets of LulzBot, Fargo 3D Printing Repair, and Protosthetics. In 2024, he joined Blue Comply as the Director of Product.

Nile J. Morecraft, PE earned his B.S. degree from South Dakota State University (SDSU) in Electrical Engineering (2017) as well as his M.S. degree from Montana State University (MSU) in Electrical Engineering (2024). He has been involved in the electrical consulting field since 2017 which included the design of electrical power distribution systems, and control system wiring infrastructure for oil production well sites. For his master's thesis, he developed a new design method and current control strategy for fast charging Lithium-Ion batteries which was implemented in hardware using the LLC resonant power converter topology.

### Vareberg Engineering

Vareberg Engineering, Ltd. is a reputable North Dakota company specializing in electrical engineering design services catering to both local and regional clients. Established with a commitment to excellence, Vareberg Engineering has successfully undertaken projects across 42 states, showcasing its versatility and proficiency. With a diverse portfolio spanning various industries including oil & gas, hospitality, education (both secondary and higher), industrial, healthcare, commercial, government and retail facilities, Vareberg Engineering has earned a reputation for delivering innovative solutions tailored to each client's needs. The company's electrical services encompass a wide spectrum, including the design of power distribution, control systems, lighting, life safety, and communications infrastructure.

### Continental Resources

Continental Resources is a major energy producer in the United States. They are known for operating their company at the highest ethical and environmental standards. With their numerous assets in the Bakken (and elsewhere), they are always eager to step up to the forefront and participate in the development of additional tools for the monitoring of fugitive gases. This has been demonstrated already with continuous reductions in Greenhouse Gas emissions from their sites over the last 5 years.

### Methane Emissions Technology Evaluation Center

The Methane Emissions Technology Evaluation Center (referred to as METEC) is a unique and renowned test and research facility for emissions leak detection and quantification (LDAQ) technology development, field demonstration, hands-on LDAQ equipment training, and protocol and best practices development. The METEC facility is operated by the Energy Institute at Colorado State University (CSU) and is located on CSU's foothills campus.

The five-year METEC 2.0 project funded by the Department of Energy, will extend the life and capability of DOE-funded assets that have been developed at the METEC facility since 2016 to speed deployment of next-generation leak detection and quantification technology solutions.

### North Dakota State University

North Dakota State University is a distinguished land grant institution, which holds the prestigious R1 research classification located in Fargo, North Dakota. Within its academic landscape, the College of Engineering at NDSU offers a rich array of opportunities, boasting 13 majors and 19 graduate programs in 8 distinct departments. The engineering programs and research initiatives are geared toward addressing the evolving needs of society.

Chad A. Ulven received his B.S. degree in Mechanical Engineering from NDS (2001) and M.S. and Ph.D. degrees in Materials Engineering from the University of Alabama at Birmingham (2003 & 2005). He has been a faculty member in the Mechanical Engineering Department at NDSU since August of 2005. He has been involved in the research of polymer matrix composites (PMCs) for various commercial and defense applications for the past 18 years. He has co-authored 6 book chapters, 70 journal articles, and over 100 conference papers related to PMCs. He has been a co-author of 5 patent applications which have led to 2 patents awarded and 2 spin-out companies

(c2renew inc. and c2sensor corp.). Most recently he was awarded a multi-million-dollar research project to help develop advanced composite material 3D printers for Army applications.

Benjamin D. Braaten received the Ph.D. degree in electrical and computer engineering from NDSU (2009). During the 2009 Fall semester, he held a Postdoctoral Research position at the South Dakota School of Mines and Technology in Rapid City, SD. He is currently a Professor in the Department of Electrical and Computer Engineering, North Dakota State University. His research knowledge includes printed antennas, conformal self-adapting antennas, microwave devices, topics in EMC, wireless sensing technology and methods in computational electromagnetics. Dr. Braaten received the College of Engineering and Architecture Graduate Researcher of the Year Award. He also serves as an Associate Editor for the IEEE Antennas and Wireless Propagation Letters and the IET Microwaves, Antennas and Propagation journal.

## MANAGEMENT

The Project Manager, Troy Vareberg, will be working directly with all parties to guarantee objectives and milestones are met. During the design phase, bi-weekly meetings shall be held to review the progress of each participant. Short-term and long-term schedules shall be adjusted (accelerated or extended) as needed for the project to continue towards the desired outcomes. Tasks shall be assigned to each participant and documented for review at the subsequent meeting. Any deviations from the schedule (planned or unplanned) and /or assigned tasks will be discussed among all participants and either resolved or adopted in a timely manner.

During the continued testing and pilot project phases, the Project Manager will coordinate the installation of the sensors with METEC, Continental Resources, EOG Resources and other Producers. Team members from Blue Comply and each Producer shall then meet on-site on a monthly basis to inspect the installed devices to verify proper performance and to verify their capabilities to withstand the various environmental factors found on site.

All parties of the team will also have access to data obtained and transmitted via the system in order to monitor the site in real time and develop methods to collect and interpret data.

For documentation of project progress, the Project Manager shall file quarterly reports to indicate current status, milestones met, deviations from timeline, necessary adjustments and projections for the next report. Within each quarterly report, the progress of the project shall be evaluated based on the following:

- Were milestones met?
- Were there any unanticipated roadblocks in the process of meeting those milestones?
- What lessons were learned to help reduce any future roadblocks?
- Are costs in line with the published grant application?
- With the results obtained to this date, does the project continue to present itself as a viable solution to effectively monitor methane gas leaks?



**BUDGET**

<b>Project Associated Expense</b>	<b>Total Costs</b>	<b>NDIC Share</b>	<b>Applicant Share (Cash)</b>	<b>Applicant Share (In-kind)</b>	<b>Other Project Sponsor Share</b>
Power Supply Refinement	\$150,000	\$75,000	\$37,500	\$37,500	\$0
Comm and Data Integration	\$150,000	\$75,000	\$37,500	\$37,500	\$0
Additional Monitoring Points	\$100,000	\$50,000	\$25,000	\$25,000	\$0
Emission Quantification	\$250,000	\$125,000	\$62,500	\$62,500	\$0
Field Testing (METEC/Producers)	\$100,000	\$50,000	\$25,000	\$25,000	\$0
Certifications (UL/FCC)	\$150,000	\$75,000	\$37,500	\$37,500	\$0
TOTAL	\$900,000	\$450,000	\$225,000	\$225,000	\$0

### **CONFIDENTIAL INFORMATION**

There is currently no confidential information related to this project.

### **PATENTS/RIGHTS TO TECHNICAL DATA**

A patent was issued by the United States Patent & Trade Office for the methane detection devices being utilized for this project.

### **STATUS OF ONGOING PROJECTS**

This project (Phase I) previously received funding from the NDIC - OGRF that was in place from June 1, 2022 through May 31, 2024.

**APPENDIX A**  
**LETTERS OF SUPPORT**

Please see the attachments.



May 15, 2024

Troy Vareberg  
Blue Comply  
1331 32<sup>nd</sup> Avenue South  
Fargo, ND 58103

Subject: Well Site Fugitive Emissions Monitoring Devices

Dear Mr. Vareberg,

This letter serves to confirm Continental Resources' support for Blue Comply's efforts to develop an offering of well site fugitive emissions monitoring devices that would enable early detection of fugitive emissions from select sources. Such devices could have the potential for reducing fugitive emissions from common sources by facilitating rapid response and repair programs, ultimately minimizing site emissions.

Continental Resources remains committed to maintaining and improving industry best practices for minimizing emissions and look forward to exploring reasonable and practical solutions with Blue Comply.

A handwritten signature in black ink, appearing to read "Kevin Turner", is positioned above the typed name.

Kevin Turner  
Emissions Program Manager  
Continental Resources