

Distributed Geothermal Power

Contract No. R-021-030

Final Report

April 15, 2017

Submitted by:

**Michael Mann
Institute for Energy Studies**

**Will Gosnold
Harold Hamm School of Geology and Geological Engineering**

University of North Dakota

Distributed Geothermal Power

Executive Summary

The UND-CLR Binary Geothermal Power Plant was a collaborative effort of the U.S. Department of Energy (DOE), Continental Resources, Inc. (CRL), Slope Electric Cooperative (SEC), Access Energy, LLC (AE), Basin Electric Cooperative (BEC), Olson Construction, the North Dakota Industrial Commission Renewable Energy Council (NDIC-REC), the North Dakota Department of Commerce Centers of Excellence Program (NDDC-COE), and the University of North Dakota (UND). The primary objective of project was to demonstrate/test the technical and economic feasibility of generating electricity from non-conventional, low-temperature (90 °C to 150 °C) geothermal resources using binary technology. CLR provided the access to 98 °C water flowing at 51 l s⁻¹ at the Davis Water Injection Plan in Bowman County, ND. Funding for the project was from DOE –GTO, NDIC-REC, NDD-COE, and BEC. Logistics, on-site construction, and power grid access were facilitated by Slope Electric Cooperative and Olson Construction. Access Energy supplied prototype organic Rankine Cycle engines for the project.

The potential power output from this project is 250 kW at a cost of \$3,400 per kW. A key factor in the economics of this project is a significant advance in binary power technology by Access Energy, LLC. Other commercially available ORC engines have efficiencies 8 to 10 percent and produce 50 to 250 kW per unit. The AE ORC units are designed to generate 125 kW with efficiencies up to 14 percent and they can be installed in arrays of tens of units to produce several MW of power where geothermal waters are available. This demonstration project is small but the potential for large-scale development in deeper, hotter formations is promising. The UND team's analysis of the entire Williston Basin using data on porosity, formation thicknesses, and fluid temperatures reveals that 4.0×10^{19} Joules of energy is available and that 1.36×10^9 MWh of power could be produced using ORC binary power plants.

Much of the infrastructure necessary to develop extensive geothermal power in the Williston Basin exists as abandoned oil and gas wells. Re-completing wells for water production could provide local power throughout the basin thus reducing power loss through transmission over long distances. Water production in normal oil and gas operations is relatively low by design, but it could be one to two orders of magnitude greater in wells completed and pumped for water production. A promising method for geothermal power production recognized in this project is drilling horizontal open-hole wells in the permeable carbonate aquifers. Horizontal drilling in the aquifers increases borehole exposure to the resource and consequently increases the capacity for fluid production by up to an order of magnitude.

Lessons Learned

1. Determine target formations. Data from oil and gas operators, state oil and gas regulatory agencies, and state geological surveys help to identify producing formations and their properties.
2. Determine the quantity of energy available in the target formations.
 - a. A complete thermal analysis of the basin or region yields the most useful information.
 - b. Critical data include bottom-hole temperatures, heat flow, stratigraphy, lithology, lithological properties, thermal conductivity, and subsurface structure.
3. Determine the potential for fluid production.
 - a. State oil and gas regulatory agencies and state geological surveys have data on oil, gas, and water production. State water commission/agencies have data on water quality, aquifers, and regulations.
 - b. Consider single horizontal wells, multiple conventional wells, and unitized fields.
4. Calculate energy production capacity of each formation based on different well combinations and power-plant scenarios. This is a broad overview rather than a site-specific analysis.
5. Research and understand the local electrical power industry. Obtain the PPA before committing to the project.
6. Work with the high-level personnel in the oil company partner. Obtain a memorandum of understanding that addresses all issues in the project, including what to expect if the company goes out of business or changes management.
7. Be prepared for project delays.

Table of Contents

Project Objectives	1
Executive Summary	1
Lessons Learned	2
Table of Contents	4
List of Tables	5
List of Figures	5
Introduction	7
1.0 Objective One	
Demonstrate the Feasibility of Binary Power Generation	7
1.1 Identification of Resource	7
1.2 Selection of Binary Power Equipment	9
1.3 Project Delays	10
1.4 Installation and Commissioning	11
1.5 System Operations	15
1.6 Project Economics	16
2.0 Objective Two	
Demonstrate that Binary Power Production can be duplicated in other Regions	19
2.1 Overview of Williston Basin and Geothermal Aquifer Systems	19
2.1 Subsurface Temperature Analysis and Resource Estimates	20
2.2 Methods	20
2.3 A New Perspective – Horizontal Drilling for Geothermal Resources	24
3.0 Objective Three	
Dissemination of Results and Training of Future Geothermal Workers	25
1.1 Faculty Involved in the Project	25
1.2 Graduate Students and Thesis Topics	26
Program of Study in Geothermal Energy	28
References	30
Appendix I Table of steps in Startup and Commissioning	
Appendix II Selection Criteria for Binary Power Equipment	
Appendix III Publications by UND Geothermal Team	

List of Tables

	Page no.
Table 1.1 CREST model summary	17
Table 1.2 Detailed cash flows for first 10 years of project	18
Table 1.3 Annual project cash flow, returns and other metrics	18
Table 2.1 Energy stored in the North Dakota portion of the Williston Basin	24
Table 3.1 Students in the geothermal program at UND	27

List of Figures

Figure 1.1 Temperature & depth contour maps based on corrected BHT data for the Madison, Red River, and Deadwood formations	8
Figure 1.2 Comparison of equivalent nominal levelized tariff rate for evaluated ORC Systems	9
Figure 1.3 Google Earth image of the Davis Water Injection Plant in the Cedar Hills oil field	11
Figure 1.4 Google Earth image of the Davis Water Injection Plant showing locations of the UND-CLR ORCs	12
Figure 1.5 ORC units installed at the Davis Water Injection Plant	12
Figure 1.6 Inside of shipping container showing ORC systems and control unit	13
Figure 1.7 Screen shot of user interface for remote access to the ORC system	15
Figure 1.8 Screen shot of south ORC unit during operation	16
Figure 2.1 Cross section of the Williston Basin in North Dakota and the ND stratigraphic column showing the main aquifer systems.	19
Figure 2.2 Temperature-depth plot showing observed temperatures, BHT temperatures and corrected BHT temperatures demonstrating application of TSTRAT	21
Figure 2.3 Temperature-depth plot showing observed temperatures, BHT temperatures and corrected BHT temperatures for NDGS #6840	22
Figure 2.4 Temperature-depth plot showing observed temperatures, BHT temperatures and corrected BHT temperatures for NDGS #3479	22
Figure 2.5 Temperature-depth plot showing observed temperatures, BHT temperatures and corrected BHT temperatures for NDGS #2894	23
Figure 2.6 Temperature-depth plot showing observed temperatures, BHT temperatures and corrected BHT temperatures for NDGS #5086	23
Figure 2.7 Temperature and depth contours for the Deadwood (Cambrian) formation	24
Figure 2.8 Temperature (colors) and depth (contours) for the Red River (Ordovician)	

Formation	25
Figure 2.9 Temperature (colors) and depth (contours) for the Madison (Mississippian)	
Formation	26

Distributed Geothermal Power

This final report for R-021-030, Distributed Geothermal Power, comprises three sections, each of which focuses on a specific objective. The objectives are: 1) Demonstrate the technical and economic feasibility of generating electricity from low-temperature geothermal fluids using binary power generation technology, 2) Show that the process can be replicated within a wider range of physical parameters including geothermal fluid temperatures, flow rates, and the price of electricity sales, 3) Widely disseminate the results of this study and to assist the development of a skilled work force. Each objective was successfully completed, however continuous production of power was delayed due to problems with the air-cooled condenser systems of the ORCs. Details of the power production system and a path forward are presented in section 1.4.

1.0 Objective 1 - Demonstrate the Technical and Economic Feasibility of Binary Power Generation using Low to Intermediate Temperature Resources

The critical steps for achieving Objective 1 were identification of a resource, acquire access to the resource, and select and install a binary power system. Resource identification was aided by results from previous research^{1,2} which showed that temperatures in the range of 90 °C to 150 °C occur throughout the Williston Basin. Six regional aquifer systems containing eleven different formations are capable of producing significant volumes of water in single wells configured for water production. Four of the aquifer systems have temperatures above 90 °C and the waters contained in them represent a significant resource of approximately 6.8 EJ. This resource estimate is for the water contained in the aquifers and is discussed in Objective 2. Figure 1.1 shows temperature and depth contours based on corrected bottom-hole temperatures for the Madison Fm., Red River Fm. and Deadwood Fm. Stratigraphic positions of the formations are shown in Figure 2.1

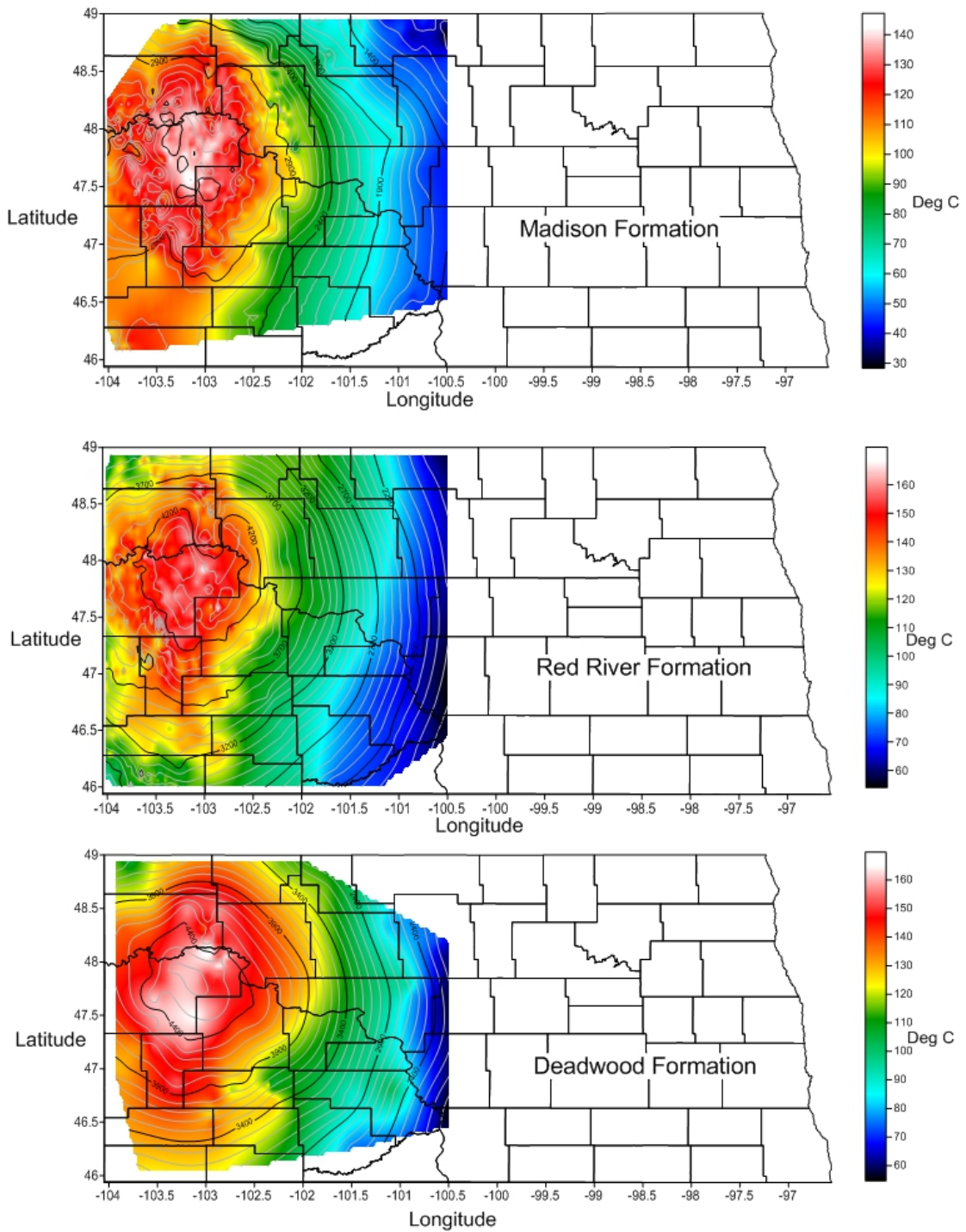

Figure 1.1 Temperature & depth contour maps based on corrected BHT data for the Madison, Red River, and Deadwood formations. Temperature contours are in color and depth contours are shown by contour lines in meters. Approximately 40 percent of North Dakota is underlain by aquifers with temperatures above 90 °C.

1.1 Identification of Resource

We identified a promising resource through contact with the North Dakota Geological Survey Oil and Gas Division. In response to inquiry, NDGS informed UND to the possible availability of hot water at the Davis Water Injection Plant in the Cedar Hills oil field in Bowman County, North Dakota ND. The site is operated by Continental Resources, Inc. (CLR), a company based in Enid, OK. A telephone call to the Vice President for Research at CLR drew immediate interest, and after in-person meetings between UND and CLR personnel in Enid OK, we reached agreement to undertake the project.

The geothermal resource selected for the project was the hot water stream from a secondary-recovery water-flood operated by Continental Resources, Inc. (CLR) in the Cedar Hills Red River-B oil field in the Williston Basin. Two 8-inch diameter open-hole horizontal wells at 2,300 m and 2,400 m depths with lateral lengths of 1,290 m and 860 m produce water at a combined flow of 51 l s^{-1} . The two water supply wells, Davis 44-29, API No: 33-011-90121-00-00 and Homestead 43-33, API No: 33-011-90127-00-00 s are 570 m and 340 m from the power plant and the water flows through uninsulated pipes buried below the frost line. Water temperature is $103 \text{ }^{\circ}\text{C}$ at the wellheads and $98 \text{ }^{\circ}\text{C}$ at the ORC inlet. The source formation is the Lodgepole (Mississippian), which is the lower member of the Madison Group, and injection is into the Red River formation (Ordovician). The hydrostatic head for the Lodgepole is at ground surface and the pumps, which are set at 735 m and 967 m depths, have run continuously since 2009. Prior to installation of the binary power plant, CLR passed the water through two large air-cooled heat exchangers for reasons of safety and to minimize heat effects on the injection pumps.

1.2 Selection of Binary Power Equipment

Selection of the power conversion system entailed a request for proposals from six binary power equipment manufacturers: Pratt & Whitney, Ormat, Recurrent, Calnetix, Electrathem, and Deluge. Given details on fluid temperature, flow rate, fluid composition, and annual and monthly temperatures at the site, the six suppliers were asked to respond to 27 separate items for the evaluation, the details of which are in Appendix III. After analysis of the responses and applying the CREST model on the relevant data, we selected the Calnetix system.

The CREST model showed that based upon the equivalent nominal levelized tariff rate, the Calnetix system offers the potential for the lowest rate at $4.45 \text{ } \phi/\text{kWh}$. The levelized rates for the other systems are compared in Figure 1.2, showing in rank order of Calnetix, Deluge, Recurrent, Pratt & Whitney, Ormat, and Electrathem.

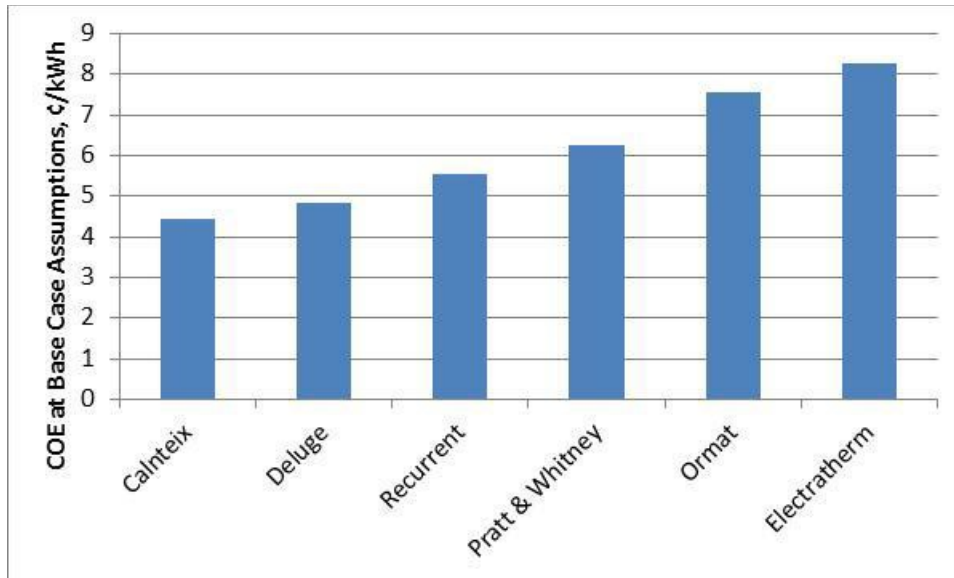

Figure 1.2. Comparison of equivalent nominal levelized tariff rate for evaluated systems

Two 125 kW Calnetix organic Rankine cycle (ORC) engines are installed in the water stream between the wellheads and the heat exchangers, and the electrical power generating capacity is 250 kW.

1.3 Project Delays

Installation of the ORC power plant experienced numerous delays that derived from the diverse capabilities, interests, and modes of operation of the three partners (UND, CLR, AE) and would not likely occur in a single party power plant startup. The first delay was an issue with UND having access to the CLR site. For reasons of liability and safety, CLR required UND to agree to a contract that the UND Office of Grants and Contracts would not allow. The specific matter was indemnification of CLR in case of an accident involving UND. This matter is common for state universities in contracts with industry and is often solved by both parties either agreeing to remain silent on the issue or by each agreeing to assume their own responsibility. UND first attempted to resolve the issue through telephone and email contacts between UND Counsel and CLR attorneys, but CLR would not accept any agreement other than full compliance. After about six months of delay, a solution to the problem was reached by having the ORC manufacturer, Access Energy (a branch of Calnetix) assume responsibility for the project on the CLR site. Unfortunately, this led to CLR dropping an offer of \$500,000 in cost share for the project since UND was no longer the principal participant on site.

The greatest time delay arose from a large and unanticipated increase in the cost for site preparation and installation. The initial estimate for site preparation and installation provided by

CLR and Access Energy was \$20,000 and UND had budgeted \$30,000 in the proposal. The kickoff for the project was in 2009 and that coincided with the onset of the Bakken oil boom in the Williston Basin. The effect of the Bakken oil boom was to cause skyrocketing costs for oil field service contractors. The only bid for site preparation and installation was \$285,410, almost 10 times the amount budgeted. The UND team overcame this hurdle by securing a grant from the North Dakota Renewable Energy Council for \$291,000, but the process delayed activity on the project for 2 years.

With the funding on hand for installation, UND and CLR anticipated startup in the summer of 2013, but it turned out that Access energy had not assembled the machines and this caused another 2 years of delay. During the waiting period, CLR determined that additional site preparation of an additional \$50,000 was necessary to protect from the possibility of spillage. The UND team was able to obtain \$50,000 from Basin Electric to cover that expense.

1.4 Installation and Commissioning

The following section summarizes the installation and the limited operation of the geothermal system. Two 125 kW Thermapower™ ORC 125 XLT units developed by Access Energy / Calnetix Technologies were installed on Continental Resources, Inc. Davis Water Injection Plant. These units were specifically designed for this project and including modifying Calnetix's existing mid-temperature design (130 °C working fluid temperature) to efficiently recover heat from the lower temperature resources available in Williston Basin.

Figures 1.3 and 1.4 are Google Earth images of the site and the location of the ORC system. Figure 1.5 is a photo of the system as installed at the site. The following provides an overview of the development and installation, including the major issues faced by the project. Operational data from the very limited time the unit was in operation is presented in section 1.6 along with an updated CREST model simulation updates of the economics for the project.



Figure 1.3. Layout of the Cedar Hills field including the Davis Water Injection Site



Figure 1.4. Davis water injection plant – ORC located in northeast corner of the site.



Figure 1.5 ORC units as installed at the Davis Water Injection site.

Each of the two 125 kW ORC systems were constructed and installed in their own separate shipping containers. The shipping containers serve to house the system once installed on site. This can be seen in Figure 1.5. Figure 1.6 shows one of the ORCs installed inside of the shipping container. The two cooling systems, seen on the top of the shipping containers, were shipped separately and installed on site. Construction of the units including full installation in the shipping containers was performed by Calnetix. All site work including mounting the heat exchangers was performed on-site by a contractor (Olson Construction). The work scope of the contractor is provided as Table 1 in Appendix I. If the installation is replicated at other sites, it is anticipated that similar site work would be needed to be performed by the host site. The implications of this will be discussed later in the economics section, as it does impact the overall project cost and the anticipated project returns. It is worth noting at this point that the Calnetix design is based upon a working/geothermal temperature of 105 C and access to a cooling tower. This system has a 95 C temperature with a custom designed air heat exchanger. Although the cooling/condenser system did not perform as designed and requires rework, the unit was able to meet the specified electricity production, even at this low working temperature.



Figure 1.6. Inside of shipping container showing ORC system and control unit

The overall shipping, installation, and startup of the system was not without issues. A review of the events is provided here along with proposed next steps to fully implement this technology. After a series of project delays the units were shipped by Access Energy and arrived at the CRI Davis site in November, 2015. Once the systems arrived and further discussions were held with CRI, Slope Electric, and Olson Construction, it was determined that additional equipment was required to accomplish the electric grid tie-in. In addition, CRI required a buried tank and water line to sump as a contingency in the event the system tripped during the winter. This was to allow water to drain from the system and to preclude freezing of any of the process lines. The sump also will allow CRI the ability to collect and dispose of the drained fluids in a manner consistent with their environmental and safety policies.

Olson Construction completed the installation March 2016 and awaited the Access Energy on-site commissioning team to charge the system with R245fa and to go through the system startup. One of the first observations of the start-up team was that the ORCs were shipped with fresh water in the cooling systems for the transformers. The cooler radiators had frozen and were broken. When the cooling plates in the transformers were inspected they were compromised too. While the startup team was at the site, they exchanged parts between the two units and were able to get the south unit online. It was put on line for the weekend, and shut down for the evenings. The south unit was putting out 124 kW.

After sitting over the summer awaiting repairs, Calnetix attempted to start the system, but a system alarm indicated low refrigerant level. It was unclear if there was a leak in the line, debris in the line from the installation, or another problem. Subsequent inspection indicated several problems requiring more serious intervention than just adding refrigerant. One problem was identified to be hold up of the refrigerant in the condenser; but it was determined that, at a minimum, the next steps were to include dismantling the units, cleaning them out, and putting them back together. Prior to getting the units back on line, an early and unanticipated winter storm hit the area. Since the unit had not been winterized, water in several of the lines froze causing additional damage to the system. The repair costs to correct the original problem with the refrigerant loss, cooling system, and damage caused by the freeze damage were beyond the budget available for the project. Therefore, at this point no additional testing or development was performed on the project.

After a review of the issues that were seen in implementing the Calnetix technology at the Davis Water Injection Site, several recommendations for future development were identified. First, and perhaps most important, it was determined that there were no issues identified with the ORC system itself. The south unit, when it was operational, produced the design amount of electricity. The issues were isolated to the cooling/condensing system. Therefore, the primary recommendation is a different configuration for the cooling system which would remove many of the issues/variables that were identified in the condensing system. Basically, the recommended design would have a container with a closed loop system inside, and would allow for a water/glycol loop to a condenser that can be mounted on ground level. A circulating pump for the cooling water would be included. Calnetix has some design ideas based upon other sites that use their technology.

At this point in the project, the team discussed various options to determine possible next steps. Two primary options were identified, both requiring a considerable amount of funding. The first option required tear down and cleaning of the system to identify the cause of the refrigerant being trapped in the condenser during the shutdowns. Also required is repair of the damage caused by the water freeze-up in the system.

The second option is to do a more complete rework of the system. Under this option, the container would be shipped back to Calnetix. This would allow them to re-use key components that were not damaged, including: XLT IPM, Power Electronics, PLC cabinet (possibly whole or parts within), R245 pump, Slam Valves, Evaporator, Hot Water Control valves, and other miscellaneous parts. Calnetix would need to do a new design for the container including a brazed plate condenser fitting within the container. Calnetix would also build a new container and assemble the new system. At this point the system would be ready to be shipped back to site and installed. Upgrades to the site layout and installation of a closed loop water system with the current air condenser would take place at the site. This would include a pump, expansion tank,

pipng, and a frame for condenser to be mounted on ground. Commissioning of the new system would be required. The major costs associated with the second option would include engineering and design time. Calnetix agreed to provide this as cost share towards the project. The cost to rebuild the units, assuming all of the parts detailed above could be salvaged, was estimated at \$200,000 to \$250,000 per unit. Additional costs were expected for the site work to remove and ship the two containers, shipping them back to the site, and site work for new configuration and installation.

1.5 Systems Operations

The two units are designated as the north unit and the south unit. The south unit was operational briefly and demonstrated the viability of the system. The system generated 124 kW of electricity, meeting the design specifications. However, due to system failures that occurred shortly after startup, the unit did not operate for a long enough period of time to optimize the performance or collect data regarding long-term operation and maintenance costs. It was determined during the operation of the unit that the cooling system, as designed, did not have the capacity to adequately cool the working fluid of both units. Therefore, the unit was not able to run at its full rated capacity. Further troubleshooting indicated that refrigerant was being held up somewhere in the cooling loop. This shortcoming appeared to be related only to the cooling system, and was not reflective of the operation of the ORC itself.



Figure 1.7 Screen shot of the user interface for the system. As a remote site, UND was able to view the primary data, but did not have the ability to access any of the control screens. The screen shots show the system producing 115 kW of electricity.

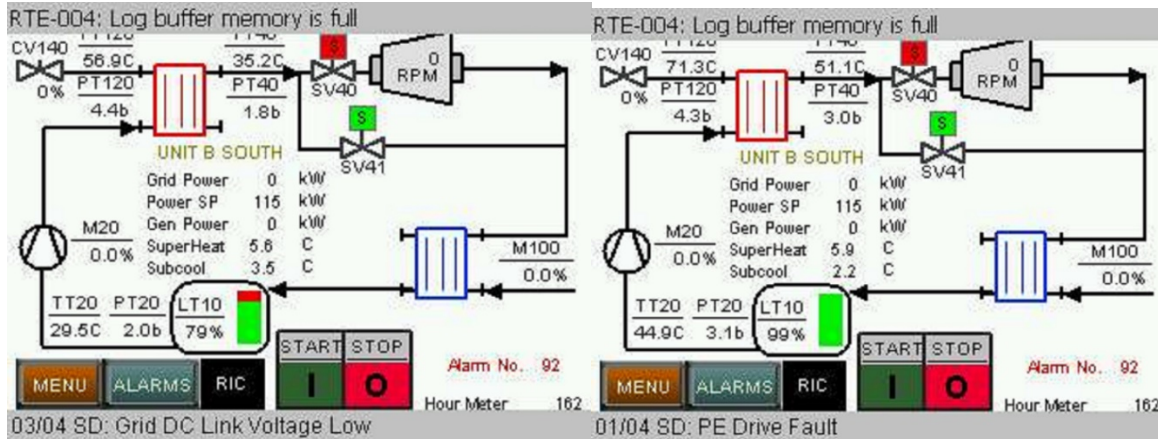

Figure 1.8. Screen shot of south unit during operation. (TT120 = Geothermal fluid temperature (°C), PT120 = Geothermal fluid pressure (bars); TT20 = Working fluid inlet temperature (°C); PT40 = Working fluid inlet pressure (bars); TT50 = Working fluid exhaust temperature (°C))

1.6 Project Economics

Project economics have been updated based upon the information obtained as a result of the installation and brief operating period. The DOE CREST model was used for this evaluation.

Based upon conversations with the Calnetix team, the budgetary price for a unit similar to the one delivered to the CRI site is \$520,000. This equates to \$2,080/kW. Olson Construction was contracted to perform the installation of the system, including the electrical interconnect. The cost to install the system, including all site preparation and interconnection was approximately \$350,000 (see Table 1 Appendix 1) for a breakdown of their work scope). The total cost of the system used for the updated economic analysis therefore was \$870,000 (\$3,480/kW). The CREST model adds an increment for reserves and financing costs, for a total estimated project cost of \$890,663. Other assumptions used in this model include: 50:50 debt: equity; 7% interest on debt; 15 yr. debt repayment; 12% after tax IRR; 35% federal tax rate; 6.5% state tax rate; 25 yr. project life; 90% C.F.; no ITC; 50% bonus depreciation in year 1; 5 yr. MACRS depreciation for the power plant and 15 yr. MACRS depreciation for the interconnect. There was no cost assigned to completing the wells since for this type of installation, the wells will be in place. There is no well-replacement allocated to the projects since the quality of the resource (the water flow rate) will increase over time rather than become depleted as is the case for conventional geothermal systems. The temperature of the water was assumed to remain constant over the life of the project, and this is valid for extraction of water from a deep formation with no injection of cold fluid. The results of the CREST economic modeling are given in Tables 1.1-1.3. Based upon the above set of assumptions and the cost data generated during this project, the anticipated cost of electricity is 7.25 ¢/kWh. The cumulative cash flow of the project will be positive during

the fifth year of the project. The pretax equity IRR for the project is estimated at 8.5% and the after tax equity IRR is 12.3%.

Table 1.1. CREST Model Summary

Outputs Summary	<i>units</i>	
Year-One Cost of Energy (COE)	<i>¢/kWh</i>	7.25
Annual Escalation of Year-One COE	%	0.0%
Percentage of Tariff Escalated	%	0.0%
Does modeled project meet <i>minimum</i> DSCR requirements?		Yes
Does modeled project meet <i>average</i> DSCR requirements?		Yes
Equivalent Nominal Levelized Tariff Rate	<i>¢/kWh</i>	7.25
Inputs Summary		
Generator Nameplate Capacity	<i>MW</i>	0.25
Net Capacity Factor, Yr 1	%	90.0%
Annual Degradation of Thermal Resource	%	0.0%
Payment Duration for Cost-Based Incentive	<i>years</i>	25
Project Useful Life	<i>years</i>	25
Exploration	\$	\$0
Confirmation Wells	\$	\$0
Production/Injection Wells	\$	\$0
Power Plant	\$	\$870,000
Interconnection (include in power plant costs)	\$	\$0
Reserves & Financing	\$	\$20,663
Net Project Cost	\$	\$890,663
Net Project Cost	<i>\$/kW</i>	\$3,563
% Equity (% hard costs) (soft costs also equity funded)	%	50%
Target After-Tax Equity IRR	%	12.00%
% Debt (% of hard costs) (mortgage-style amort.)	%	50%
Interest Rate on Term Debt	%	7.00%
Is owner a taxable entity?		Yes
Type of Federal Incentive Assumed		Cost-Based
Tax Credit Based or Cash Based?		Cash Grant
Other Grants or Rebates		No

2.0 Objective Two - Demonstrate that Binary Power Production can be Replicated in Other Regions

2.1 Overview of the Williston Basin and Geothermal Aquifer Systems

The critical variables in power generation using formation waters are 1) production volume and 2) temperature. This project achieved an optimal solution for production volume by using open-hole horizontal wells thus maximizing borehole exposure to the water bearing formation. The Davis well has a vertical depth of 2,163 m and a horizontal length of 1,494 m for a total drill length of 3,658 m. The Homestead well has a vertical depth of 2,306 m and a horizontal length of 810 m for a total drill length of 3,197 m. Both wells are 8.75 " (0.222 m) diameter open-hole laterals in a high-porosity zone of the Lodgepole Formation (Miss.) with casing only in the vertical segments. The hydrostatic head for the Lodgepole is at ground surface, and the down-hole pumps are set at 735 m and 967 m for the Davis and Homestead wells respectively.

In work under Objective 2, we developed a clear understanding of the temperatures in the Williston Basin and we have produced several reports on temperature-depth relationships in all formations³⁻¹⁵. In brief, there are six regional aquifer systems containing eleven different formations. Four of the aquifer systems have temperatures above 90 °C and the waters contained in them could be developed for binary electrical power generation.

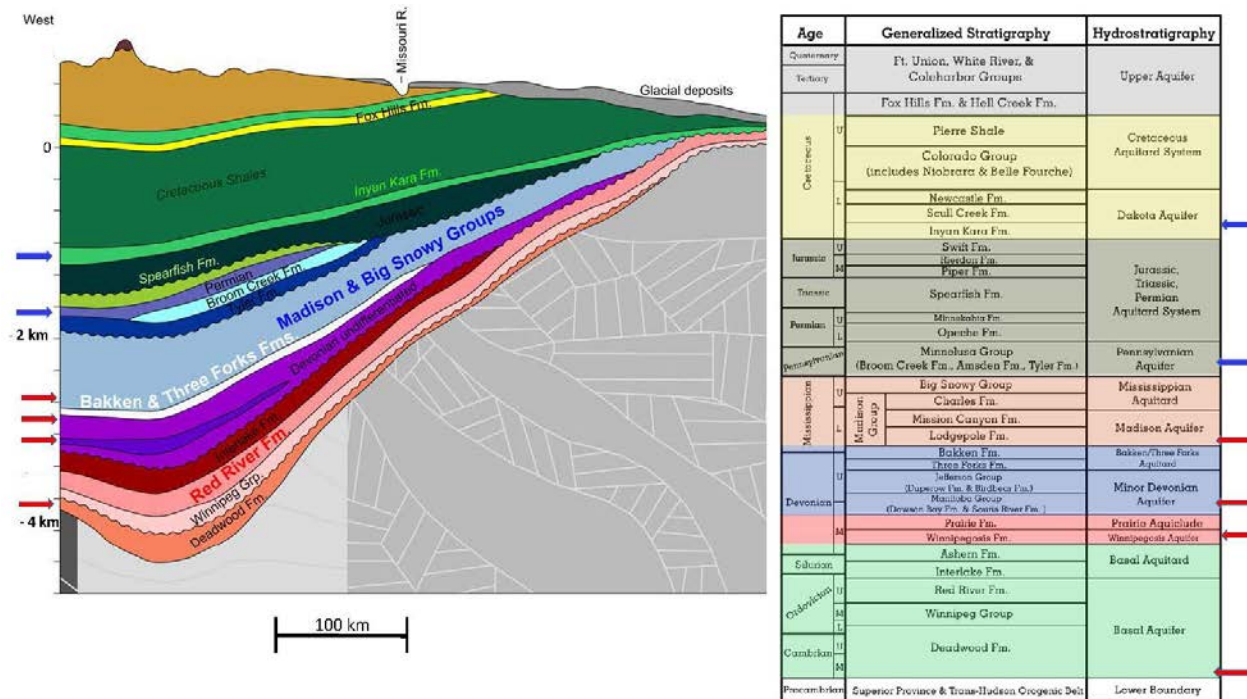

Figure 2.1 Cross section of Williston Basin in North Dakota and stratigraphic column. Blue arrows indicate aquifer systems with temperatures in the 90 °C to 100 °C range. Red arrows indicate aquifer systems with temperatures above 100 °C.

2.2 Subsurface Temperature Analysis and Resource Estimates

Temperatures, depths to formations, and formation properties were determined from a variety of data. The result is that there is good potential for power production throughout the basin. At least eleven water-bearing formations with temperatures greater than 90 °C extend over areas of several 10s of km². The total energy contained in the rock volume of those geothermal aquifers is 283.6 EJ (1 EJ = 10¹⁸ J). The total energy contained in the water volume, determined from porosities, which range from 2 percent to 8 percent, is 6.8 EJ. The aquifers grouped by 10 °C temperature bins (Table 2.1) include one or more formations due to the bowl-shape structure of the basin.

Table 2.1 Energy stored in the North Dakota portion of the Williston Basin grouped by 10 °C temperature bins.

T °C	km ³ Rock	km ³ Water	EJ Rock	EJ Water
90° -100°	192,467	10,486	3.2E+01	1.7E+00
100° -110°	255,799	12,430	3.2E+01	1.7E+00
110° - 120°	226,723	10,937	5.2E+01	9.9E-01
120° - 130°	204,628	10,166	5.7E+01	1.0E+00
130° - 140°	122,569	5,333	6.0E+01	1.1E+00
140° - 150°	60,806	1,766	4.1E+01	8.4E-01
T ≥ 150°	45,248	1,257	1.9E+01	5.3E-01

2.3 Methods for Temperature Analysis

The specific formations most exploited for oil and gas operations provide the greatest amount of data for assessing temperatures. These data exist as bottom-hole temperatures, which are well-known to underestimate temperatures at depth. Through multiple analyses based on equilibrium temperature-depth data, heat flow, thermal conductivity and stratigraphy, we developed correction schemes and generated accurate temperature contour maps of exploitable formations^{5, 10-12}. We used a method we designate as *Thermostratigraphy* (TSTRAT). The required data for *thermostratigraphy* analysis are formation lithology and thickness, heat flow, and thermal conductivity. Where heat flow is conductive and constant, the temperature gradient varies inversely with thermal conductivity and one can calculate an accurate “synthetic” T-z profile using

$$T(z) = T_0 + \sum_{i=1}^n \frac{qz_i}{\lambda_i} \quad \text{Eq. 2.1}$$

where: $T(z)$ is the temperature at depth z , T_0 is surface temperature, q is heat flow, z_i is the thickness of a formation and λ_i is the thermal conductivity of the formation.

Figure 2.2 illustrates the application of Eq. 1. The blue line is a temperature-depth profile measured in a dry hole, NDGS 2894, at thermal equilibrium conditions. The gold triangles are temperatures calculated on formation tops using eq. 1. The agreement between calculated and measured temperatures indicates that the value used for heat flow at this well is correct, and it can be used to project temperatures below the measurement. The dark red circles are bottom-hole temperature measurements in wells within 10 km of NDGS 2894, and the green diamonds are corrections to the BHTs using the Harrison equation. We applied this method to a number of sites to develop our understanding of subsurface temperatures in the basin.

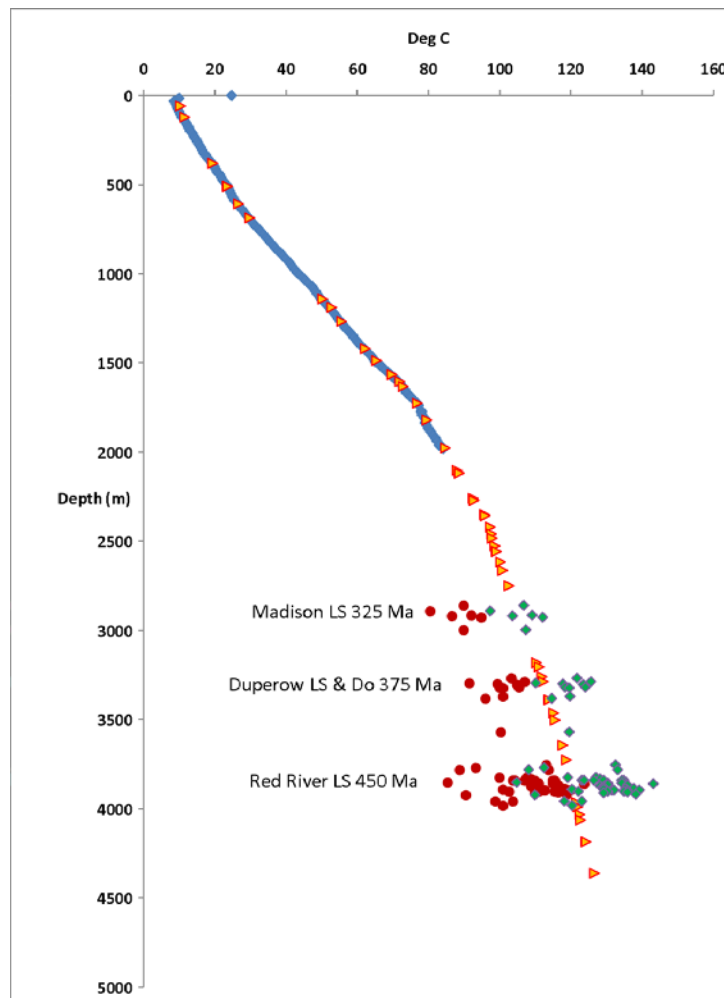

Figure 2.2 Demonstration of TSTRAT. An equilibrium temperature vs depth plot, blue line, is overlain by temperatures calculated by TSTRAT on formation tops, red-gold triangles. BHT data from wells within 10 km of the observation well, red dots, were corrected with the Kehle correction¹⁸, green diamonds, which tends to under correct at shallow depths and over correct at greater depths.

Five temperature vs. depth profiles that were measured in boreholes at thermal equilibrium. Four of the profiles are entirely in the shale section, but one profile, NDGS 6840, reached a depth of 2845 m and extends through the Madison Group carbonates. The temperature gradient in the Madison between 2640 and 2845 m averages $16.9 \pm 2.4 \text{ K km}^{-1}$. Core from the well was not available for thermal conductivity measurements, but it was estimated as follows. The average temperature gradient in the shale section of NDGS 6840 is $46.9 \pm 11.6 \text{ K km}^{-1}$ and the shale section has a thermal conductivity of $1.1 \text{ W m}^{-1} \text{ K}^{-1}$. This yields a heat flow of 51.6 mW m^{-2} for that site. Assuming constant heat flow in the borehole, the thermal conductivity of the Madison in NDGS is calculated to be $3.05 \text{ W m}^{-1} \text{ K}^{-1}$. Using heat flow of 51 mW m^{-2} and adjusting thermal conductivities of each formation penetrated by the borehole, TSTRAT can fit a calculated temperature profile to the observed profile. The method was used to calculate temperatures on all formation tops from the bottom of the observed temperature data to the Precambrian basement.

The analysis was applied to each of the four wells with T-z profiles and the results were combined with the bottom hole temperature data from all boreholes within a 10 km of the well (Figures 2.3 & 2.4). A small but persistent misfit between the calculated temperature vs. depth profile and the observed profiles occurs in the upper km of each of the five boreholes. The misfit is inferred to be due to a transient disturbance of the temperature gradient in the upper 1 km from the effects of post-glacial warming^{14, 16}. These results improved our understanding of heat flow and subsurface temperatures in the basin. In fact, the results indicate a higher heat flow throughout the basin than was determined from shallow temperature vs. depth measurements.

The CLR water flood project has proved ideal for demonstration of electrical power production from a low-temperature geothermal resource. The key result of Objective 1 is that accessing horizontal wells provides the path to achieving Objective 2, i.e., demonstrating where else the technology can be applied. CLR currently produces 1,934 gpm of 100 °C water from five horizontal water supply wells in the Cedar Hills oil field. The air-cooled Calnetix ORC engines could produce approximately 750 kW of electrical power from that water flow. Considering that 16 kW to 25 kW of power is required for a single well, CLR could provide power for 30 to 46 wells. By installation of an ORC unit on each of the wells.

The two 125 kW ORC engines on site were provided as cost share by Calnetix. However, the economics of the system are highly favorable since it is a “piggyback” operation on existing infrastructure. The price for the 125 kW XLT systems used for this demonstration is expected to be \$260,000 per unit for similar applications. Installation costs will vary depending upon existing site conditions. According to CLR, the cost of drilling and completing the two horizontal wells was more than \$2M each. The Access Energy ORC is designed to sit on a gravel pad with easy connection to the water and electrical lines.

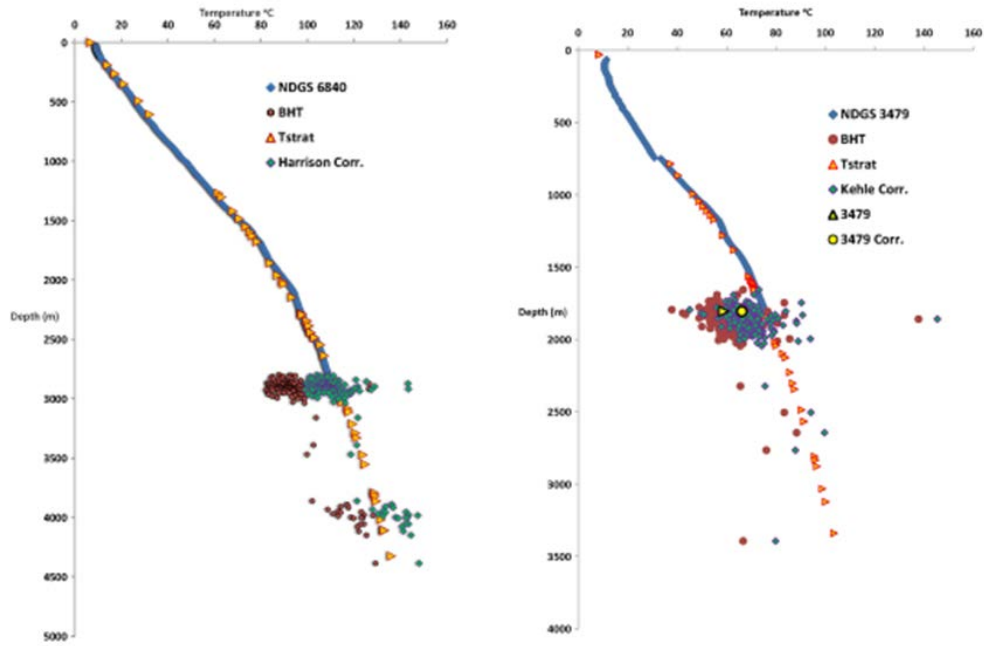

Figures 2.3 and 2.4. Application of TSTRAT for wells NDGS 6840 and NDGS 3479 which have equilibrium temperature vs. depth logs. The BHT data are from wells within 10 km of the two wells.

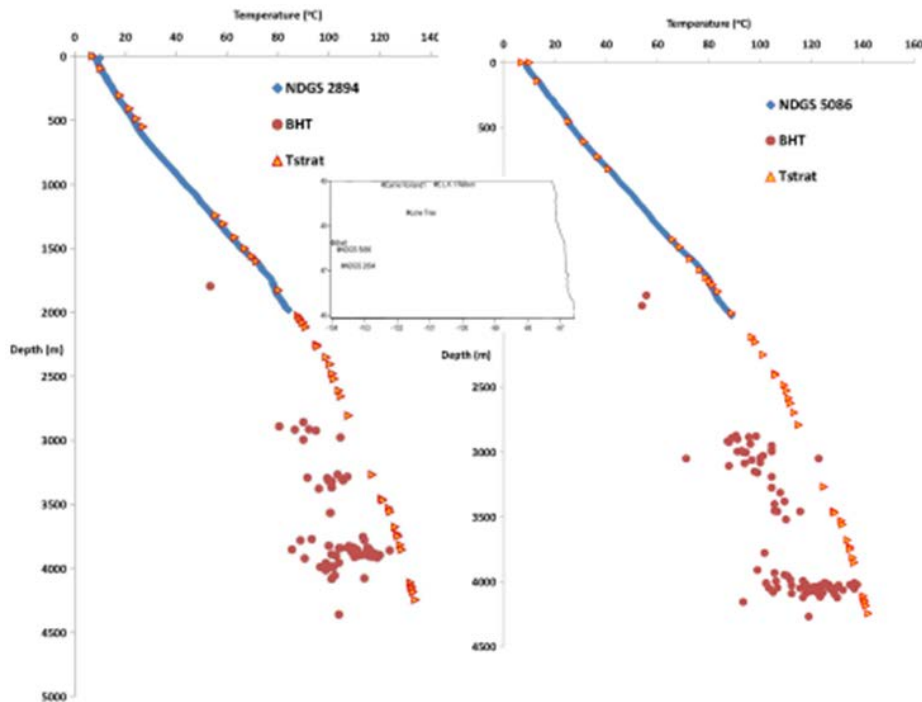

Figures 2.5 and 2.6. Application of TSTRAT for wells NDGS 2894 and NDGS 5086 which have equilibrium temperature vs. depth logs. The inset map shows locations for these two wells and NDGS 6840 (Shell) and NDGS 3479 (ELK1 Nelson).

2.4 A New Perspective – Horizontal Geothermal Drilling

The water flood operation at the CLR site adds a new perspective for geothermal development in a sedimentary basin. Conventional development would be vertical wells drilled into geothermal aquifers. Drilling open-hole lateral wells within a relatively flat or gently dipping geothermal aquifer greatly increases the volume of water that can be produced. An intriguing possibility would be to drill 6 to 8 laterals radially from a single pad. Three moderately high temperature aquifers in the Williston Basin, the Deadwood (Cambrian), Red River (Ordovician), and Madison (Mississippian) offer potential for this type of development. The rocks are competent and laterals can be open-hole, i.e., without lateral casing, and they are permeable enough to yield significant amounts of water. Figures 2.7, 2.8, and 2.9 were developed from the National Geothermal Data System (NGDS) bottom-hole temperature data for North Dakota and show the temperatures and depths for these formations.

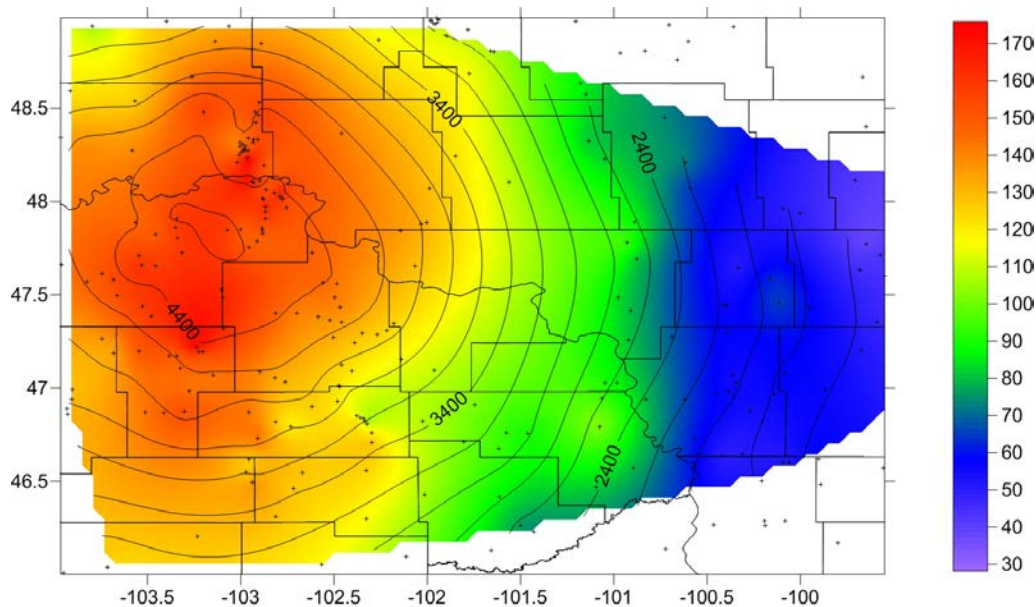

Figure 2.7. Temperature (colors) and depth (contours) for the Deadwood Formation.

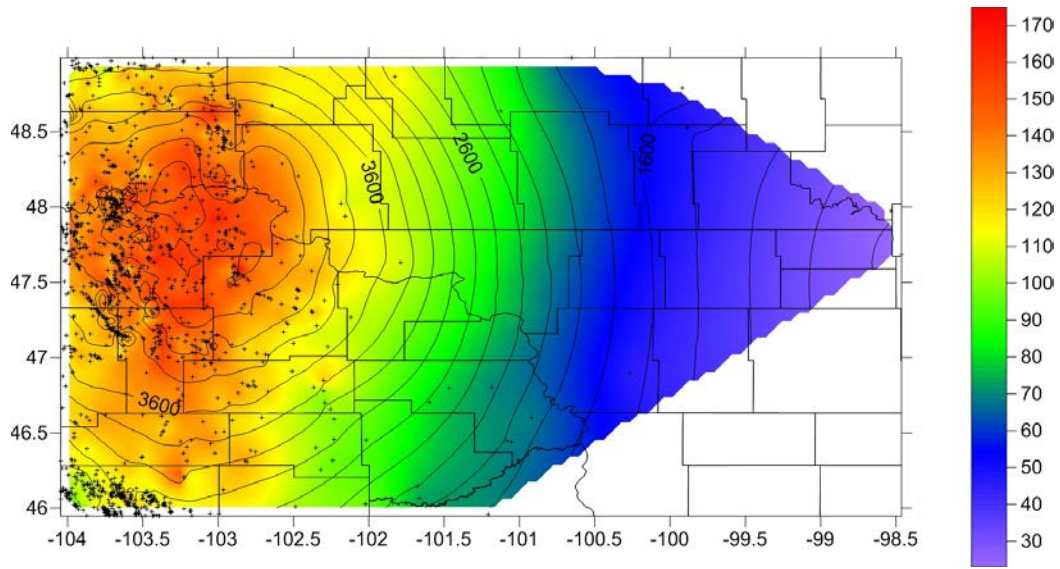

Figure 2.8. Temperature (colors) and depth (contours) for the Red River Formation.

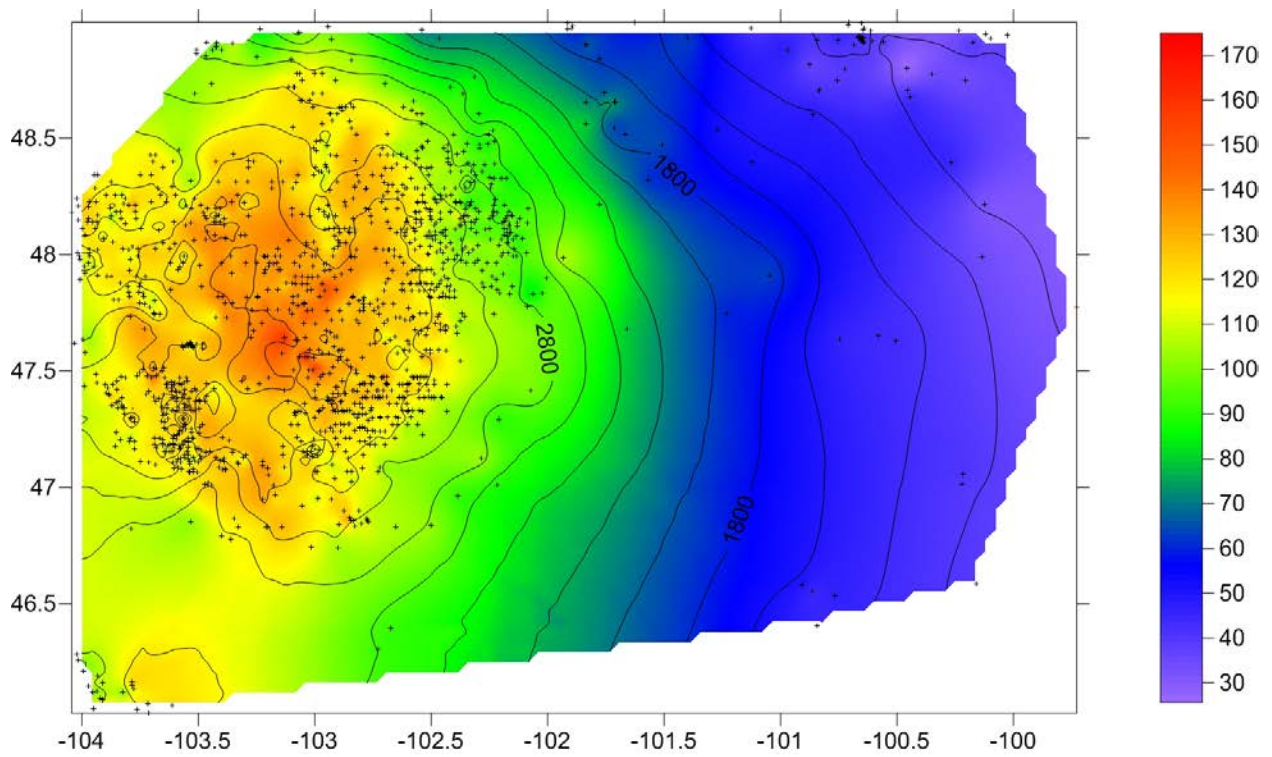

Figure 2.9. Temperature (colors) and depth (contours) for the Madison Formation.

Objective 3. Dissemination of Results and Training of Future Geothermal Workers

Objective 3 of the project was highly successful. The team has produced 29 peer-reviewed papers and made 67 presentations at professional meetings (Appendix III). PI Gosnold has presented talks on the project in six of the eight SMU geothermal conferences¹⁸. He has presented invited talks on the project in two of the SedHeat¹⁹ workshops and at a Geothermal Energy Association workshop²⁰. He discussed the project as a presenter at an AAPG workshop on geothermal energy in the oil patch²¹ and as a presenter at a Geothermal Resources Council workshop²².

The program has produced 5 PhDs, 7 MS, and 3 BS students with theses in geothermal energy. The team has involved 7 faculty in 4 different engineering and science disciplines, Chemical Engineering, Electrical Engineering, Geological Engineering, and Geology. Faculty involved in the program developed four graduate level courses covering different elements in heat flow and geothermal energy that are now offered in the Harold Hamm School of Geology and Geological Engineering. A major link between this project and the UND Petroleum Research, Education, and Entrepreneurship Center (PREEC) provided matching funds of \$297,512 and personnel for some aspects of the project. Funding for PREEC was from the North Dakota Department of Commerce Centers of Excellence program and development of geothermal power in North Dakota is one of the missions of the Center.

3.1 Faculty Involved in the Project:

P.I. Will Gosnold, Chester Fritz Distinguished Professor
Harold Hamm School of Geology and Geological Engineering
Director of the UND Petroleum Research, Education, and Entrepreneurship Center (PREEC)

Co-P.I. Michael Mann, Chester Fritz Distinguished Professor, Chemical Engineering
Executive Director of Institute for Energy Studies, Co-PI for PREEC which provided \$297,512 in cost-share, PI for NDIC-REC grant for \$261,000, co-Author on four publications, CREST analysis

Co-P.I. Hossein Salehfar, Professor, Electrical Engineering
Associate Dean, College of Engineering and Mines, Co-PI for PREEC which provided \$297,512 in cost-share, co-Author on four publications, Electrical power interconnect design

Senior personnel: Richard LeFever, Associate Professor
Harold Hamm School of Geology and Geological Engineering
Co-P.I. on PREEC, which provided \$297,512 in cost-share, co-author on three publications, Stratigraphy and BHT data analysis

Senior personnel: Dongmei, Wang, Assistant Professor
 Harold Hamm School of Geology and Geological Engineering
 Research Scientist-Engineer on PREEC and co-author on a GRC publication

Senior personnel: Zheng Wen Zeng, Assistant Professor
 Harold Hamm School of Geology and Geological Engineering
 Co-P.I. on PREEC, which provided \$297,512 in cost-share

Senior personnel: Stephen Nordeng, Associate Professor
 Harold Hamm Distinguished Professor of Petroleum Geology, co-author on a GRC publication

3.2 MS Students and Thesis Topics

Table 3.1 Students in the Geothermal Program at UND 2011-2017

Student	Background	UND Degree	Thesis Title	Current Position
Robert Klenner	BS Geology UND	MS (2011)	Heat Flow and Geothermal Energy in Minnesota	Lead Geoscientist for Reservoir Performance Team at GE Oil & Gas Tech. Center
Anna Crowell	BS Park University	MS (2011)	Identifying Potential Geothermal Resources from Co-produced Fluids Using Existing Data from Drilling Logs: Williston Basin, North Dakota	Instructor, Harold Hamm School of Geology and Geological Engineering, University of North Dakota
Godswill Njoku	BS Geology Nigeria	MS (2013)	Climate Signal in Heat Flow	Oil Production Williston Basin
Eric Zimny	BS Geology UND	MS (2014)	Radioactive Background of Home Stake Mine	Environmental Scientist, Sacramento, CA
Aaron Ochsner	BS Geology UN-Omaha	MS (2014)	Heat Flow and Groundwater Flow in NW Nebraska	Scientist at AECOM, Omaha
Caitlin Hartig	BS Geology Penn State	MS (2015)	Balance Between Natural and Stimulated Fractures for Energy Extraction	Solar City Las Vegas, NV
Faye Ricker	BS Geology U. Florida	MS (2015)	Geothermal Regime of the Williston Basin in North Dakota	Pursuing PhD in Environmental Science and Policy U. South Florida
Dylan Young	BS Geology UND	MS (2017)		

Daniel Brunson	BS Geology U. Alabama	MS (2017)		Applying for PhD Program
Josh Crowell	BS Park University MS Geology UND	PhD (2015)	Thermal Conductivity of Williston Basin	Instructional Support Technologist UND
Samir Dahal	BS Electrical Engineering NYU Polytechnic	PhD (2014)	Geothermal Electric Power from Binary Plants	Senior System Studies Engineer, Mitsubshi Electric Power
Anna Crowell	MS Geology UND	PhD (2015)	Evaluating Sedimentary Basins for Geothermal Power Production Potential and Bottom-Hole Temperature Corrections	Instructor, Harold Hamm School of Geology and Geological Engineering, University of North Dakota
Mark McDonald	BS, MS Geological Engineering UND	PhD (2013)	Geophysical Investigation of the Rye Patch KGRA	Heat Flow and Geothermal Scientist, North Dakota Geological Survey (deceased)
Kirtipal Barse	BS Chemical Engineering, University of Pune MS Chemical Engineering UND	PhD (2014)	Analysis of Binary Power Systems	Research Engineer in UND Institute for Energy Studies

3.3 Program of Study in Geothermal Energy

With support from the ND Centers of Excellence (PREEC) program, we have developed three graduate courses for a program of study in geothermal energy. These courses are taught by HHSGGE faculty Gosnold, Wang, Mahmood, Ho, and Nordeng, and faculty in the UND Department of Petroleum Engineering offer relevant classes in geomechanics, drilling and reservoir analysis that support the geothermal program.

GEOL 551 Heat Flow An exploration of Earth's thermal structure, thermal history and heat sources. The course begins with the theory of heat transfer within and through the surface of terrestrial planets. Methods of observation and modeling provide hands-on experience in field and laboratory activities. Applications of heat flow in tectonics, petrology, thermal maturity of kerogen, hydrogeology, geothermics and climate change are presented with current examples.

GE 591 Geothermal Engineering The course explores engineering aspects of geothermal power with a focus on adapting petroleum engineering methods to geothermal applications

GEOL 560 Geothermics I A survey of the methods of geothermal exploration, assessment and production. The course covers the various methods for discovery and characterization of geothermal resources. Methods for assessment of energy in place and determination of recoverable energy are covered in depth. Current technologies for energy extraction and power production are presented with current examples.

GEOL 561 Geothermics II The course covers the historical development of geothermal policies, regulations and practices globally and in different states within the US. Matters of water usage, contamination and disposal are covered extensively. Current issues such as induced seismicity, hydrofracture, power plant size and location, electrical grid access and land use are critically examined.

3.4 Publications, Presentations, and Abstracts - this list covers 2008-2016

The list of publications, presentations, and abstracts are included as Appendix II. The list includes material from 2008 although the project did not officially begin until January, 2009. The activity in 2008 came after UND became aware of the award.

References

1. Gosnold, W.D., Jr., Subsurface Temperatures in the Northern Great Plains, *Neotectonics of North America: Boulder, Colorado, Geological Society of America, Decade Map Volume 1*, 467-472, 1991
2. Gosnold, W.D., Jr., Stratabound geothermal resources of North Dakota and South Dakota, *Natural Resources Research*, 8: 177-192, 1999
3. Gosnold, Will, McLaughlin, Samantha, & Colby, Christopher, Three-Dimensional Temperature Structure of the Williston Basin, *GRC Transactions*, 40, 639-642, 2016
4. Williams, Tom, Snyder, Neil, and Gosnold, Will, Low Temperature Projects Evaluation and Lesson Learned, *GRC Transactions*, 40, 203-210, 2016
5. Crowell, A. and W. Gosnold, Integrating Geophysical Data in GIS for Geothermal Power Prospecting, Geological Society of America Publication: GEOSPHERE, Accepted for Publication, 2015
6. Gosnold, Will, Anna Crowell, Stephan Nordeng and Michael Mann, Co-Produced and Low-Temperature Geothermal Resources in the Williston Basin, *GRC Transactions*, 39, 653-660, 2015
7. Gosnold, W. and A. Crowell, Heat Flow and Geothermal Research in Mid-Continent of North America, *Transactions of the Geothermal Resources Council*, vol. 38, p. 127-131, 2014
8. Crowell, A. and W. Gosnold, Geothermal Resource Assessment of the Michigan and Illinois Basins: How Deep is Too Deep? *Transactions of the Geothermal Resources Council*, vol. 38, p. 947-949, 2014
9. Gosnold, W., K. Barse, B. Bubach, A. Crowell, J. Crowell, H. Jabbari, A. Sarnoski and D. Wang, Co-Produced Geothermal Resources and EGS in the Williston Basin, *Transactions of the Geothermal Resources Council*, vol. 37, p. 721-726, 2013
10. Gosnold, Will, McDonald, Mark, Klenner, Robert, and Merriam, Daniel, Thermostratigraphy of the Williston Basin, *Geothermal Resources Council Transactions*, 36, 663-670, 2012
11. Crowell, A., and W. Gosnold, 2011, "Correcting Bottom-Hole Temperatures: A Look at the Permian Basin (Texas), Anadarko and Arkoma Basins (Oklahoma), and Williston Basin (North Dakota)," *Transactions of the Geothermal Resources Council*, vol. 35, p. 735-738
12. Crowell, A. M.; Klenner, R.; and W. Gosnold, 2011. "GIS Analysis for the Volume and Available Energy of Selected Reservoirs: Williston Basin, North Dakota," *Transactions of the Geothermal Resources Council*, vol.35. p. 1557-1561
13. Gosnold W., Mann, M. and H. Salehfar, 2011. "Geothermal in the Oil Field." Search and Discovery Article #80172, Adapted from oral presentation at AAPG Annual Convention and Exhibition, Houston, Texas, USA, April 10-13, 2011

14. Gosnold, W., LeFever, R., Mann, M., Klenner, R., and H. Salehfar, 2010. "EGS Potential in the Northern Midcontinent of North America." Transactions of the Geothermal Resources Council, vol. 34, p. 355-358
15. Gosnold, W., LeFever, R., Klenner, R., Mann, M., Salehfar, H., and J. Johnson, 2010, "Geothermal Power from Coproduced Fluids in the Williston Basin." Transactions of the Geothermal Resources Council, vol. 34, p. 557-560
16. Dahal, S., H. Salehfar, W. Gosnold, M. D. Mann, Modeling and Simulation of the Interface between Geothermal Power Plant Based on Organic Rankin Cycle and the Electric Grid, Transactions of the Geothermal Resources Council, 34, 1011-1016, 2010
17. Majorowicz, Jacek, Gosnold, Will, Gray, Allan, Safanda, Jan, Klenner, Rob, Unsworth, Martyn. Implications of Post-Glacial Warming For Northern Alberta Heat Flow – Correcting For the Underestimate of the Geothermal Potential. Geothermal Resources Council Transactions, 36, 693-698, 2012
18. Kehle, R.O., Schoepel, R. J., and Deford, R. K., 1970, The AAPG Geothermal Survey of North America, Geothermics, Special Issue 2, U.N Symposium on the Development and Utilization of Geothermal Resources, Pisa 1970, Vol. 2, Part 1
19. SMU Geothermal Workshops 2006-2016
<http://www.smu.edu/Dedman/Academics/Programs/GeothermalLab/Conference>
<http://www.smu.edu/Dedman/Academics/Programs/GeothermalLab/Conference/PastPresentations>
20. ARMA-AAPG SedHeat Workshop, Successful Engineering of Sedimentary Geothermal Systems, 50th Rock Mechanics/Geomechanics Symposium, June 24-25, 2016, Houston, TX & Unlocking the Energy Elephant: A SedHeat Workshop, March 1-4, 2017, Salt Lake City, UT
21. 2017 International Geothermal Forum, Geothermal Energy Association, March 7, 2017, Washington, DC
22. AAPG Pre-Convention Short Course SC12 (EMD), An Overview of Geothermal Energy, April 10, 2011, Houston, TX
23. GRC Workshop: Introduction to Hydrothermal Systems and Geothermal Exploration, GRC Annual Meeting, 2014, Portland, OR

Appendix I: Table of Steps in Startup and Commissioning

Appendix 1. Work scope for on-site contractor to prepare site and install ORC system

Item	Description	Labor & Construction Equipment	Material
1	Design Work - Design and Approval		
1.1	Design Work - Site Survey and piping/electric wiring design in CAD format	Contractor	
1.2	Design Work - ORC foundation & quick mountings design, and electric cable trench design	Contractor	
1.3	Design Work - Electrical (Power and Communication) Cable trench work	Contractor	
1.4	Design Work - ORC mounting design onto ORC foundation and quick mounts - Approval by AE	Access Energy	
1.5	Design Work - ORC mounting design onto ORC foundation and quick mounts - Approval by Continental Resources	Continental Resources	
2	Installation - Supply and delivery of all materials and equipment for ground preparation (gravel), foundation, ORC mountings and construction	Contractor	Contractor
2.1	Gravel	Contractor	Contractor
2.2	Trucking (Gravel)	Contractor	Contractor
2.3	6" I-Beam - including delivery to site	Contractor	Contractor
2.4	Concrete	Contractor	Contractor
3	Installation - Installation of ORC foundations per agreed design	Contractor	Contractor
3.1	Grade Soil	Contractor	Contractor
3.2	Install Piles	Contractor	Contractor
3.3	Install I-Beams with Mounts	Contractor	Contractor
3.4	Pour Gravel	Contractor	Contractor
4	Unloading and site assembling	Contractor	

4.1	Unload and install ORC containers on foundation mountings per drawing 206-24291 (detailed 2-D Drawing will be available later)	Contractor	Access Energy
4.2	Unload and install condensers/frames/wire conduit onto the top of containers per drawing 206-24291 (detailed 2-D Drawing will be available later)	Contractor	Access Energy
4.3	Unload, clean and install refrigerant piping (including PSV vent piping) per drawing 206-24291 (detailed 2-D Drawing will be available later)	Contractor	Access Energy
4.4	Install electric box-Main Grid Disconnect and re-connect wires per 330-24785	Contractor	Access Energy
4.5	Install electric box-Instrumentation Panel and re-connect wires per 330-24785	Contractor	Access Energy
4.6	Install exhaust fans and re-connect wires per 330-24785	Contractor	Access Energy
4.7	Unload and install IPM on to the system per drawing 206-24291 (detailed 2-D Drawing will be available later)	Contractor	Access Energy
5	Supply and install electric power cable/steel conduit/trench to grid connection per NEC	Contractor	Contractor
5.1	Installation - Trench per design between ORC Units and Identified Location per Trench Design	Contractor	Contractor
5.2	Materials - Supply Power Cables	Contractor	Contractor
5.3	Materials - Supply Conduit including all fittings, supports and hardware	Contractor	Contractor
5.4	Installation - Conduit for Power Cables per redline on hand marked drawing 330-24302 and 330-24785 dated Nov.6.2014	Contractor	Contractor
6	Supply and install conduits, Ethernet cables and Beckwith cable in instrument conduits to CLR server/router and grid line.	Contractor	Contractor
6.1	Installation - Install Conduit and cables for Ethernet and (Beckwith) Signal Cables per hand marked drawing 330-24302 dated Nov. 6. 2014	Contractor	Contractor
6.2	Materials- Supply Ethernet Cables, Control Cables, and Signal Cables	Contractor	Contractor
6.3	Materials - Supply Conduit including all fittings, supports and hardware	Contractor	Contractor

7	Conduct and pass Nitrogen leak test per AE supplied spec ER-1071 on Refrigerant side of ORC systems after re-assembly.	Contractor	Contractor
7.1	Materials- 90% Nitrogen and 10% R245fa		Contractor
8	Reconnect condensing unit (electrical) ref. drawing 330-24785	Contractor	Access Energy
9	Supply, welding and Install hot water piping/valves/strainers/supports/gaskets/bolting/insulation/paint(touch ups and supports)	Contractor	Contractor
9.1	Welding of piping and pipe supports	Contractor	Contractor
9.2	Completion of hot water piping pressure test @ 330 psi for 30 minutes to check welds and flange connection leaks (Plug PSV port during test)	Contractor	Contractor
9.3	Materials:-Supply pipe supports	Contractor	Contractor
9.4	Materials:-Supply pipe/flange/gaskets/bolting/ and all other materials necessary	Contractor	Contractor
9.5	Materials:-Supply shut-off valves/ pressure safety valves and strainers free issued from AE	Access Energy	Access Energy
9.6	Completion of hot water pipe insulation and supports paint	Contractor	Contractor
9.7	Material:-Insulation, paint	Contractor	Contractor
10	Supply and install Beckwith Monitoring	Contractor	Contractor
10.1	Materials - Beckwith Monitoring System	Contractor	Contractor
10.2	Connect Beckwith monitoring and test (from Beckwith to ORC PLC)	Contractor	Contractor
11	Connect internet service and test (from CLR internet to ORC PLC)	Contractor	Contractor
12	Supply and Installation - 500 amp Service Panel -Connection with Main Breaker	Contractor	Contractor
12.1	Materials - 500 amp Service Panel and requisite breakers and cables	Contractor	Contractor

12.2	Installation - 500 amp service panel and connection to ORC and Grid	Contractor	Contractor
12.3	Connect 500 amps service (from grid to ORC Main Grid Disconnect enclosure) and test	Contractor	Contractor
13	Unload refrigerant bottles (need fork lift)	Contractor	Contractor
13.1	Material:-Refrigerant R245fa (4,000 lbs.)	Access Energy	Access Energy
14	Mobilization/demobilization	Contractor	Contractor

Appendix II: Selection Criteria for Binary Power Equipment

Feature	Ormat	Pratt & Whitney	Deluge	Recurrent	Electratherm
Output (kW)	350	430	1750	845	235
Net kW	300	407	1487.5	750	191
Water Input, gpm	875	870	840	834	875
Output, kW/gpm	0.34	0.47	1.77	0.9	0.22
Footprint (sq. ft.)		420	2800	124	3406
Remote operation	Yes	Yes	Yes		
Cooling	Air	Air	Not provided	Not provided	Forced air
No. machines	1	2	7	1	5
Working fluid	Not spec.	R245fa	liquid CO ₂	H ₂ O & NH ₃	R245fa
Delivery	10 mos	4 mos	4 to 7 mos	10 mos	4 mos
Cost	\$1,600,000	\$1,175,000	\$4,165,000	\$1,926,500	\$965,665
Extra Infrastructure	None	Building	Building	Building	Building
Extra costs for cooling	0	\$565,000	\$350,000	\$565,000	\$250,000
Warranty	1 yr.	1 yr.	1 yr.	1 yr.	ext 5 y., included
Outdoor/Indoor	Outdoor	Indoor	Indoor	Indoor	Indoor
Output voltage	480	480	480	480	480
Shipping	We pay	Yes			
Performance guarantee	Yes			Yes	
Insulation for HE and Pipe	Yes				
Connection to grid	No	Yes	No	No	No
Transportation to site	Yes	Yes	Unknown	Unknown	Yes
Special	No pad req.	Turnkey install.	Pad req.	No pad req.	Pad req.
Infrastructure	\$10,000	\$60,000	\$60,000	\$60,000	\$60,000
Total Cost	\$1,610,000	\$1,800,000	\$4,575,000	\$2,551,500	\$1,275,665
Cost per kW	\$5,367	\$4,423	\$3,076	\$3,402	\$6,679
Generation, MWh/yr	2,498	3,389	12,387	6,246	1,591
Yearly sales ¹ \$.05/kWh	\$124,912	\$169,464	\$619,356	\$312,280	\$79,527
Years to cover investment	12.9	10.6	7.4	8.2	16
Base COE ² , cents/kWh	7.55	6.25	4.85	5.55	8.25

¹ Yearly sales estimates assume 95 percent plant availability. Infrastructure costs assume \$50,000 for building and piping, electrical and other on-site costs

² Analysis based upon CREST model. 50:50 debt:equity; 7% interest on debt; 12% after tax IRR; 35% federal tax rate; 25 yr project life; 95% C.F.; no ITC; 50% bonus depreciation in year 1; 5 yr MACRS depreciation for the pov

AE

550
495
875
0.57
100
Yes
Forced air
1*
R134a
9 mos
\$1,475,000
None
0
18/12
Outdoor
350 -500
We pay
Yes
Yes
No
No pad req.
\$10,000
\$1,485,000
\$3,000
4,122
\$206,105
7.2
4.45

\$10,000 for

e; 6.5% state
ver plant and

Appendix III: Publications by UND Geothermal Team

Publications by UND Geothermal Team

1. Gosnold, Will, McLaughlin, Samantha, & Colby, Christopher, Three-Dimensional Temperature Structure of the Williston Basin, GRC Transactions, 40, 639-642, 2016
2. Williams, Tom, Snyder, Neil, and Gosnold, Will, Low Temperature Projects Evaluation and Lesson Learned, GRC Transactions, 40, 203-210, 2016
3. Crowell, A. and W. Gosnold, Integrating Geophysical Data in GIS for Geothermal Power Prospecting, Geological Society of America Publication: GEOSPHERE, Accepted for Publication, 2015.
4. Gosnold, Will, Anna Crowell, Stephan Nordeng and Michael Mann, Co-Produced and Low-Temperature Geothermal Resources in the Williston Basin, GRC Transactions, 39, 653-660, 2015
5. Crowell, J., Measuring Thermal Conductivity Using a Divided Bar: Equations for Irregular Samples, Geological Society of America Publication: GEOSPHERE, Accepted for Publication, 2015.
6. Crowell, J. and A. Crowell, The History of Lightning Dock KGRA: Identifying a Blind Geothermal Resource, Transactions of the Geothermal Resources Council, vol. 38, p. 77-83, 2014.
7. Gosnold, W. and A. Crowell, Heat Flow and Geothermal Research in Mid-Continent of North America, Transactions of the Geothermal Resources Council, vol. 38, p. 127-131, 2014.
8. Crowell, A. and W. Gosnold, Geothermal Resource Assessment of the Michigan and Illinois Basins: How Deep is Too Deep?, Transactions of the Geothermal Resources Council, vol. 38, p. 947-949, 2014.
9. McDonald, M. and W. Gosnold, Gravity Modeling of the Rye Patch Known Geothermal Resource Area, Rye Patch, Nevada, Transactions of the Geothermal Resources Council, vol. 38, p. 533-539, 2014.
10. Crowell, J. and W. Gosnold, Detecting Spatial Trends in Thermal Conductivity in the Williston Basin, Transactions of the Geothermal Resources Council, vol. 37, p. 487-490, 2013.
11. Gosnold, W., K. Barse, B. Bubach, A. Crowell, J. Crowell, H. Jabbari, A. Sarnoski and D. Wang, Co-Produced Geothermal Resources and EGS in the Williston Basin, Transactions of the Geothermal Resources Council, vol. 37, p. 721-726, 2013.
12. Crowell, A., and W. Gosnold, GIS-Based Geothermal Resource Assessment of the Denver Basin: Colorado and Nebraska, Transactions of the Geothermal Resources Council, vol. 37, p. 941-944, 2013.
13. Crowell, A. and W. Gosnold, Using the Geothermal Gradient from Oil and Gas BHTs as a Direct Indicator for Subsurface Structure and Geothermal Potential: Nebraska, North Dakota Academy of Science Proceedings, April 2013.

14. Crowell, A., A. Ochsner, and W. Gosnold, Correcting Bottom Hole Temperatures in the Denver Basin: Colorado and Nebraska, Transactions of the Geothermal Resources Council, vol. 36, p. 201-206, 2012.
15. Gosnold, W., M. McDonald, R. Klenner, and D. Merriam, Thermostratigraphy of the Williston Basin, Transactions of the Geothermal Resources Council, vol., 36, p. 663-670, 2012.
16. Dahal, S., M. McDonald, A. Crowell, and B. Bubach, Evaluation of Geothermal Potential of Lightning Dock KGRA, New Mexico, Transactions of the Geothermal Resources Council, vol. 36, p. 637-640, 2012.
17. Majorowicz, J., W. Gosnold, A. Gray, J. Safanda, R. Klenner, and M. Unsworth, Implication of Post-glacial Warming for Northern Alberta Heat Flow -- Correcting for the Underestimate of Geothermal Potential, Transactions of the Geothermal Resources Council, vol., 36, p. 693-698, 2012.
18. Barse, K., M. McDonald, and A. Crowell, Evaluation of the Geothermal Potential in the Rio Grande Rift: Truth or Consequences, New Mexico, Transactions of the Geothermal Resources Council, vol., 36, p. 693-698, 2012.
19. Crowell, A.M., Klenner, R., Gosnold, W., GIS Analysis for the Volume and Available Energy of Selected Reservoirs: Williston Basin, North Dakota, Transactions: Geothermal Resources Council, vol. 35, p. 1557-1562, 2011.
20. Klenner, R., M. McDonald, S. Dahal, A. Crowell, and A. van Oploo, Evaluation of the Geothermal Potential in the Rio Grande Rift: San Luis Basin, Colorado and New Mexico, The Mountain Geologist, vol. 48, no. 4, p.107-119, 2011.
21. Crowell, A., and W. Gosnold, Correcting Bottom-hole Temperatures: A Look at the Permian Basin (Texas), Anadarko and Arkoma Basins (Oklahoma), and Williston Basin (North Dakota), Transactions of the Geothermal Resources Council, vol. 35, p. 735-738, 2011.
22. Gosnold, W., J. Majorowicz, R. Klenner, and S. Hauck, Implications of Post-glacial Warming for Northern Hemisphere Heat Flow, Transactions of the Geothermal Resources Council, vol. 35, p. 693-698, 2011.
23. Klenner, R., W. Gosnold, J. Heine, M. Severson, and S. Hauck, An Assessment of Heat Flow and Enhanced Geothermal System Resources in Minnesota, Transactions of the Geothermal Resources Council, vol. 35, p. 425-430, 2011.
24. Blackwell, D., F. Moerchen, B. Cutright, W. Gosnold, M. Kay, S. Nagihara, C. Robinson, and J. Tester, Data Integration into the National Geothermal Data System (NGDS), Transactions of the Geothermal Resources Council, vol., 35, p. 1539-1543, 2011.
25. Crowell, A., R. Klenner, and W. Gosnold, GIS Analysis for the Volumes, and Available Energy of Selected Reservoirs: Williston Basin, North Dakota, Transactions of the Geothermal Resources Council, vol., 35, p. 1557-1561, 2011.
26. Dahal, S., H. Salehfar, W. Gosnold, and M. Mann, Modeling and Simulation of the Interface between Geothermal Power Plant Based on Organic Rankin cycle and the

Electric Grid, , Transactions of the Geothermal Resources Council, vol., 34, p. 1011-1015, 2010.

27. Klenner, R., W. Gosnold, J. Heine, S. Hauck, G. Hudak, and D. Fosnacht, New Heat Flow Map of Minnesota Corrected for the Effects of Climate Change and Assessment of Enhanced Geothermal Resources, NRRI/TR-2012/01, p. 109, 2010.
28. Gosnold, W., R. LeFever, R. Klenner, M. Mann, H. Salehfar, and J. Johnson, Geothermal Power from Co-produced fluids in the Williston Basin, Transactions of the Geothermal Resources Council, vol., 34, p. 555-560, 2010.
29. Gosnold, W., R. LeFever, M. Mann, R. Klenner, and H. Salehfar, EGS Potential in the Northern Midcontinent of North America, Transactions of the Geothermal Resources Council, vol., 34, p. 355-358, 2010.

Presentations

Twenty-six of the GRC publications were presented orally at annual GRC meetings and are not listed below; therefore, the numbering begins at twenty-seven in this list

27. Ricker, F. and W. Gosnold, Characterization of Radiogenic Heat Production from Basement Rocks and Its Relationship to Heat Flow in the Williston Basin and North Dakota, Stanford Geothermal Workshop, Stanford, CA, February 2015.
28. Crowell, J., Measuring Thermal Conductivity Using a Divided Bar: New Equations for Irregular Samples, Geological Society of America Annual Meeting, Vancouver, BC, October 2014.
29. Crowell, A. and W. Gosnold, Mapping Optimum Locations for Geothermal Power Production: Colorado, Illinois, Michigan, Nebraska, and North Dakota, Geological Society of America Annual Meeting, Vancouver, BC, October 2014.
30. Majorowicz, J., J. Chan, J. Crowell, W. Gosnold, L. Heaman, J. Kuck, G. Nieuwenhuis, D. Schmitt, M. Unsworth, N. Walsh, and S. Weides, WCSB Geothermal: Where it is hot and where it is not – A Review of Geothermal State of the Foreland Basin, Geological Society of America Annual Meeting, Vancouver, BC, October 2014.
31. Dahal, S., and H. Salehfar, Optimal Location and Sizing of Distributed Generation in Distribution Networks, accepted for publication IEEE Transactions on North American Power Symposium 2013, Manhattan, KS, September 2013.
32. Crowell, A. and W. Gosnold, Utilizing Geophysical Data and GIS to Identify Areas of Interest for Geothermal Power Production: Denver-Julesberg Basin, Colorado, North Dakota GIS Users Conference, Grand Forks, ND, September 2013.
33. Crowell, A. and W. Gosnold, Using the Geothermal Gradient from Oil and Gas BHTs as a Direct Indicator for Subsurface Structure and Geothermal Potential: Nebraska, North Dakota Academy of Science, Grand Forks, ND, April 2013.

34. Crowell, A., and W. Gosnold, Recoverable Thermal Energy for Geothermal Power Production in the Denver Basin, SMU Geothermal Conference: Geothermal Energy and Waste Heat to Power—Utilizing Oil and Gas Plays, Dallas, TX, March 2013.
35. Gosnold, W., and K. Barse, Status of the North Dakota Oil Field Geothermal Projects, SMU Geothermal Conference: Geothermal Energy and Waste Heat to Power—Utilizing Oil and Gas Plays, Dallas, TX, March 2013.
36. Crowell, A., and W. Gosnold, Available Thermal Energy in the Denver Basin Dakota Group: Colorado and Nebraska, American Geophysical Union Annual Meeting, San Francisco, CA, December 2012.
37. Crowell, J., and W. Gosnold, Using a Divided Bar Apparatus to Measure Thermal Conductivity of Samples of Odd Sizes and Shapes, American Geophysical Union Annual Meeting, San Francisco, CA, December 2012.
38. Gosnold, W., and A. Crowell, Synthesis of Bottom Hole Temperatures and Heat Flow Data, American Geophysical Union Annual Meeting, San Francisco, CA, December 2012.
39. Kirtipal B., M. Mann, W. Gosnold, and H. Salehfar, Evaluation of Organic Rankine Cycle Geothermal Power Plant and Considerations, AIChE Annual Meeting, Minneapolis, MN, October 2011.
40. Gosnold, W., J. Crowell, B. Bubach, P. Wahl, A. Crowell, M. McDonald, and R. Klenner, Minnesota Heat Flow and Geothermal Potential, American Geophysical Union Annual Meeting, San Francisco, CA, December 2011.
41. Crowell, A. and W. Gosnold, Re-Evaluating Geothermal Potential with GIS Methods and New Data: Williston Basin, North Dakota, American Geophysical Union Annual Meeting, San Francisco, CA, December 2011.
42. Gosnold, W., Geothermal Demonstration Projects in a Sedimentary Basin, Geological Society of America Annual Meeting, Minneapolis, MN, October 2011.
43. Gosnold, W., North Dakota Geothermal Binary power projects, Geothermal Energy Utilization Associated with Oil & Gas Development; SMU Geothermal Conference, Dallas, TX, June 2011.
44. Gosnold, W., M. Mann, and H. Salehfar, Geothermal in the Oil Field, AAPG Annual Conference and Exhibition, Houston, TX, April 2011.
45. Blackwell, D., F. Moerchen, I. Duncan, W. Gosnold, M. Kay, S. Nagihara, C. Robinson, and J. Tester, Developing Information for the National Geothermal Data System (NGDS); AAPG Annual Conference and Exhibition, Houston, TX, April 2011.
46. Gosnold, W., R. LeFever, M. Mann, R. Klenner, M. McDonald, and H. Salehfar, EGS Potential in the Northern Midcontinent of North America, AAPG/SPE/SEG Hedberg Conference: Enhanced Geothermal Systems, Napa, CA, March 2011.
47. Gosnold, W., and R. Klenner, Northern Hemisphere Heat Flow Has Been Underestimated, AAPG/SPE/SEG Hedberg Conference: Enhanced Geothermal Systems, Napa, CA, March 2011.

48. Crowell, A., and W. Gosnold, Using GIS to Evaluate Geothermal Potential of Sedimentary Basins: Williston Basin, North Dakota, SMU Geothermal Conference, Dallas, TX, June 2011.
49. Crowell, A., and W. Gosnold, Determining the Volumes, Porosities, and Available Energy of Selected Reservoirs Utilizing GIS Methods: Williston Basin, North Dakota, Geological Society of America Annual Meeting, Minneapolis, MN, October 2011.
50. McDonald, M., W. Gosnold, and R. Ellis, Gravity Survey of the Rye Patch KGRA, Rye Patch, Nevada, American Geophysical Union Annual Meeting, San Francisco, CA, December 2011.
51. Oschner, A., Application of the Harrison Correction to Nebraska BHT Data, Geological Society of America Annual Meeting, Minneapolis, MN, October 2011.
52. Gosnold, W., R. Klenner, and S. Hauck, Minnesota Geothermal Potential, Geological Society of America Annual Meeting, Minneapolis, MN, October 2011.
53. Crowell, A., and W. Gosnold, Identifying Potential Geothermal Resources from Co-Produced Fluids using Existing Data from Drilling Logs: Williston Basin, North Dakota, Geological Society of America Annual Meeting, Denver, CO, October 2010.
54. Gosnold, W., and R. LeFever, Heat Flow and Thermal Maturity in the Williston Basin, Williston Basin Petroleum Conference, Regina, SK, April 2009.
55. Gosnold, W., Can Geothermal Energy and Carbon Sequestration be Combined to Produce Carbon-Negative Electricity?" Initiative for Renewable Energy and the Environment, Minneapolis, MN, November 2009.
56. Gosnold, W., Thermal Maturity of the Bakken and North Dakota Geothermal Power, Great Plains Energy Expo, Great Plains Energy Corridor Headed by Senator Dorgan, Bismarck, ND, November 2009.
57. Klenner, R., and W. Gosnold, Geothermal Energy Utilization Associated with Oil & Gas Development, SMU Geothermal Conference, Dallas, TX, November 2009.
58. Gosnold, W., and R. LeFever, Electric Power from Low-temperature Geothermal Resources, Geological Society of America Annual Meeting, Portland, OR, October 2009.
59. Crowell, J., W. Gosnold, R. Klenner, N. Low, and P. Wahl, High Pressure Thermal Conductivity Research using A Stationary Divided Bar, North Dakota EPSCoR, NDSU at Fargo, ND, October 2009.
60. Klenner, R., W. Gosnold, P. Wahl, P. , N. Low, and J. Crowell, North Dakota Geothermal Power North Dakota EPSCoR, NDSU at Fargo, ND, October 2009.
61. Low, N., W. Gosnold, J. Crowell, R. Klenner, and P. Wahl, The BOSS: A lightweight Portable Seisgun North Dakota EPSCoR, NDSU at Fargo, ND, October 2009.
62. Gosnold, W., and R. LeFever, Heat Flow and Thermal Maturity in the Williston Basin , Williston Basin Petroleum Conference, ND Geological Survey, Bismarck, ND, April 2009.
63. Gosnold, W., Heat Flow and Geothermal Energy, University of Minnesota: Duluth, Duluth, MN, February 19, 2009.

64. Gosnold, W., A New Look at Geothermal Energy as an Energy Choice for the Future, Harvesting Clean Energy Conference, Billings, MT, January, 25, 2009.
65. Gosnold, W., Z. Zeng, M. Mann, and H. Salefar, Potential Impacts of Co-Produced Geothermal Waters, AAPG Annual Meeting, San Antonio, TX, April 2008.
66. Gosnold, W., and D. Poochigian, Geothermal Energy is the Ethical Energy Choice of the Future, Proceedings – Sixth International Meeting, Heat Flow and the Structure of the Lithosphere, Bykov, Czech Republic, June 2006.
67. Gosnold, W., Geothermal prospects in the North Central US, Geothermal Energy Generation in Oil and Gas Settings Conference, Dallas, TX, April 2006.